

**ESB**  
AUDIO

# 9000

High-End Speaker Series

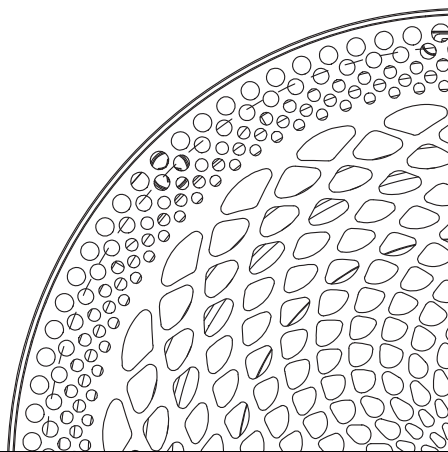

# NOVEMILA

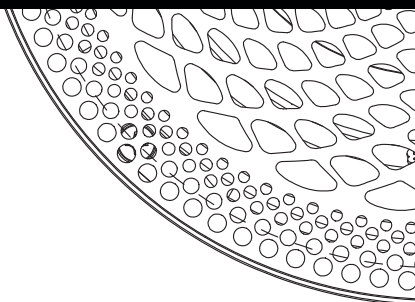

Quick Installation Manual

EN IT DE FR ES CH

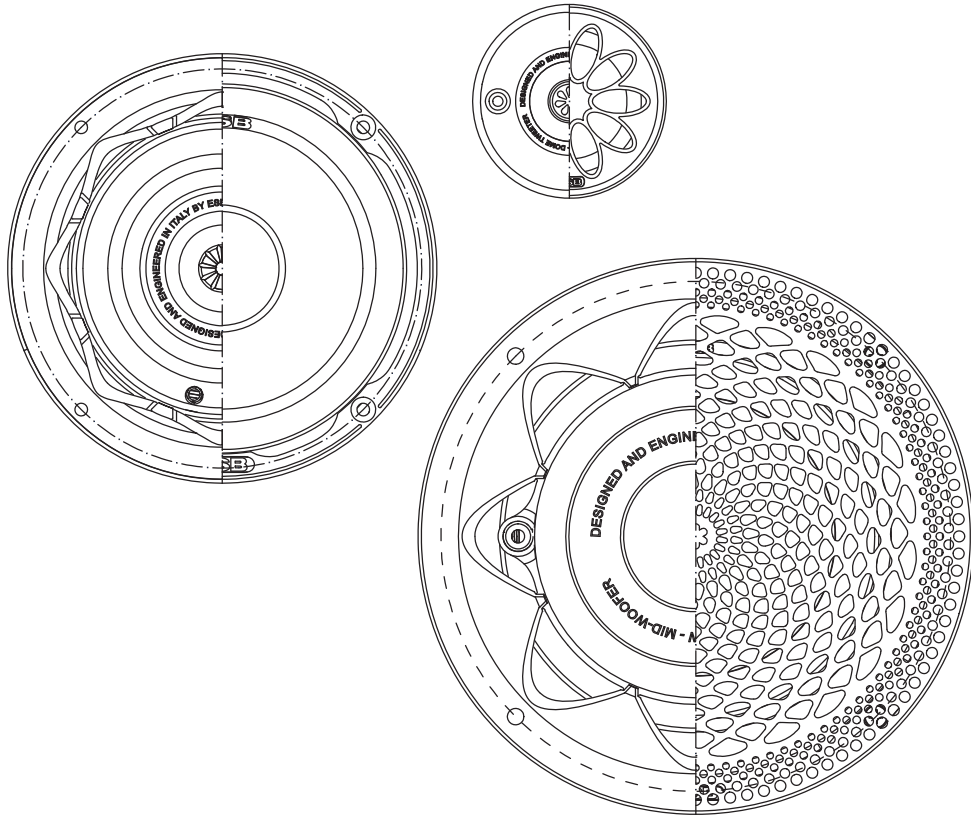

# 9000

High-End Speaker Series

## EN General Instructions

The installation of the product must be done by professional technicians. Always contact an ESB Authorized Dealer.

Thank you for purchasing your new ESB speakers. If properly installed, they will give you years of great audio experience. Although we have attempted to make sure all the information contained here are accurate, please be aware that the following instructions should be used as a general guideline only. If you are unsure about performing any of the procedures listed below, please contact a professional car audio installation center. Before and during installation, please follow these guidelines:

- For safety, disconnect the negative terminal from the battery prior to beginning the installation.
- Use the highest quality connectors for a reliable installation and to minimize signal or power loss.
- Use caution before you drill or cut. Be careful not to cut or drill into gas tanks, fuel lines, brake or hydraulic lines, vacuum lines or electrical wiring when working on any vehicle. Before drill or cut check the under side of working area.
- Never run speaker wires underneath your vehicle. Running speaker wires inside the vehicle provides the best protection from exhaust heat and environmental elements.
- Avoid running wires over, near, or through sharp edged surfaces. Use rubber grommets to protect any wires routed through metal.
- When running the speaker cable from the amplifier, avoid running it near sources of high current (i.e. wiring harnesses, battery cables).
- Pay attention to the positive and negative speaker polarity. In some vehicles, it may be possible to utilize the existing speaker wiring. When doing this, be careful of the polarity (+/-) of the speaker wires, as these wire colors vary for each vehicle. In some vehicles, it may be necessary to run new speaker wire throughout the vehicle.
- Never let the cables touch any metal part of the car as well as take care that the speaker terminals are properly away from metal parts.
- Make sure the speaker rests on an even, flat surface, use the foam gasket provided. Air leaks will cause a severe degradation in sound quality. Seal any air leaks with an automotive-grade sealant material.
- Tighten the screws diagonally and do not tighten beyond a force of about 6-8 Nm. Use a hand screwdriver or, if electric, set the clutch to low. The speaker should be tightened well, but not forced. Forcing could cause cracking and/or deformation of the basket.

Continuous exposure to excessive sound pressure levels may cause hearing damage. ESB strongly advises that you use common sense when setting volume levels. Everything written in this manual is for the proper use of the products. Some features or specifications could be modified during production to improve the product performance. The technical specifications and functionalities stated here are current as of the time of publication.

## IT Istruzioni Generali

L'installazione del prodotto deve essere effettuata da tecnici professionisti. Rivolgersi ad un Rivenditore Autorizzato ESB.

Grazie per aver acquistato i vostri nuovi altoparlanti ESB. Se installati correttamente, ti daranno anni di fantastica esperienza audio. Sebbene abbiamo cercato di garantire che tutte le informazioni contenute qui siano accurate, tieni presente che le seguenti istruzioni devono essere utilizzate solo come linee guida generali. Se non sei sicuro di eseguire una delle procedure elencate di seguito, contatta un centro di installazione audio professionale. Prima e durante l'installazione, seguire queste linee guida:

- Per sicurezza, scollegare il terminale negativo dalla batteria prima di iniziare l'installazione.
- Utilizzare connettori della massima qualità per un'installazione affidabile e per ridurre al minimo la perdita di segnale o potenza.
- Prestare attenzione prima di forare o tagliare. Fare attenzione a non tagliare o forare serbatoi del gas, tubi del carburante, tubi dei freni, idraulici, d'aspirazione o cavi elettrici quando si lavora su qualsiasi veicolo. Prima di forare o tagliare, controllare il lato inferiore dell'area di lavoro.
- Non far mai passare i cavi degli altoparlanti sotto il veicolo. Il passaggio dei cavi degli altoparlanti all'interno del veicolo offre la migliore protezione dal calore di scarico e dagli elementi ambientali.
- Evitare di far passare i cavi sopra, vicino o attraverso superfici con bordi taglienti. Utilizzare anelli in gomma per proteggere eventuali cavi intradati attraverso il metallo.
- Quando si fa passare il cavo dell'altoparlante dall'amplificatore, evitare di farlo passare vicino a fonti di corrente elevata (ad esempio cablaggi elettrici, cavi della batteria).
- Prestare attenzione alla polarità positiva e negativa degli altoparlanti. In alcuni veicoli potrebbe essere possibile utilizzare il cablaggio degli altoparlanti esistente. Durante questa operazione, prestare attenzione alla polarità (+/-) dei cavi degli altoparlanti, poiché i colori dei cavi variano per ciascun veicolo. In alcuni veicoli potrebbe essere necessario far passare un nuovo cavo per l'altoparlante in tutto il veicolo.
- Non lasciare mai che i cavi tocchino alcuna parte metallica dell'auto e fare attenzione che i terminali degli altoparlanti siano adeguatamente lontani dalle parti metalliche.
- Assicursi che l'altoparlante poggi su una superficie piana e uniforme, utilizzare la guarnizione in gomma fornita. Le perdite d'aria causeranno un grave degrado della qualità del suono. Sigillare eventuali perdite d'aria con un materiale sigillante di tipo automobilistico.
- Stringere le viti in diagonale e non serrare oltre una forza di circa 6-8 Nm. Utilizzare un cacciavite a mano o, se elettrico, impostare la frizione al minimo. L'altoparlante dovrebbe essere stretto bene, ma non forzato. Forzare potrebbe causare rotture e/o deformazioni del cestello.

L'esposizione continua a livelli di pressione sonora eccessivi può causare danni all'udito. ESB consiglia vivamente di utilizzare il buon senso quando si impostano i livelli di volume. Tutto quanto scritto in questo manuale è finalizzato al corretto utilizzo dei prodotti. Alcune caratteristiche o specifiche possono essere modificate durante la produzione per migliorare il prodotto. Le specifiche tecniche e le funzionalità qui riportate sono aggiornate al momento della pubblicazione.

## DE Allgemeine Anweisungen

Die Installation des Produkts muss von professionellen Technikern durchgeführt werden. Wenden Sie sich immer an einen autorisierten ESB-Händler.

Vielen Dank für den Kauf Ihrer neuen ESB-Lautsprecher. Bei richtiger Installation werden Sie jahrelang ein großartiges Audioerlebnis haben. Obwohl wir versucht haben, sicherzustellen, dass alle hier enthaltenen Informationen korrekt sind, beachten Sie bitte, dass die folgenden Anweisungen nur als allgemeine Richtlinie dienen sollten. Wenn Sie sich bei der Durchführung eines der unten aufgeführten Verfahren nicht sicher sind, wenden Sie sich bitte an ein professionelles Car-Audio-Installationszentrum. Bitte befolgen Sie vor und während der Installation die folgenden Richtlinien:

- Trennen Sie aus Sicherheitsgründen den Minuspol von der Batterie, bevor Sie mit der Installation beginnen.
- Verwenden Sie Steckverbinder höchster Qualität für eine zuverlässige Installation und zur Minimierung von Signal- oder Leistungsverlusten.
- Seien Sie vorsichtig, bevor Sie bohren oder schneiden. Achten Sie darauf, bei Arbeiten an Fahrzeugen nicht in Benzintanks, Kraftstoffleitungen, Brems- oder Hydraulikleitungen, Unterdruckleitungen oder elektrische Leitungen zu schneiden oder zu bohren. Überprüfen Sie vor dem Bohren oder Schneiden die Unterseite des Arbeitsbereichs.
- Verlegen Sie niemals Lautsprecherkabel unter Ihrem Fahrzeug. Die Verlegung von Lautsprecherkabeln im Inneren des Fahrzeugs bietet den besten Schutz vor Abgaswärme und Umwelteinflüssen.
- Vermeiden Sie es, Kabel über, in der Nähe oder durch scharfkantige Oberflächen zu verlegen. Verwenden Sie Gummütüllen, um alle durch Metall geführten Drähte zu schützen.
- Wenn Sie das Lautsprecherkabel vom Verstärker verlegen, vermeiden Sie es, es in der Nähe von Hochstromquellen (z. B. Kabelbäumen, Batterieablenkern) zu verlegen.
- Achten Sie auf die positive und negative Polarität der Lautsprecher. Bei einigen Fahrzeugen ist es möglicherweise möglich, die vorhandene Lautsprecherkabelung zu nutzen. Achten Sie dabei auf die Polarität (+/-) der Lautsprecherkabel, da diese Kabelfarben je nach Fahrzeug unterschiedlich sind. Bei einigen Fahrzeugen kann es notwendig sein, neue Lautsprecherkabel durch das gesamte Fahrzeug zu verlegen.
- Stellen Sie sicher, dass der Lautsprecher auf einer ebenen, flachen Oberfläche steht. Verwenden Sie dazu die mitgelieferte Schaumstoffdichtung. Luftlecks führen zu einer erheblichen Verschlechterung der Klangqualität. Eventuelle Luftlecks mit einem für die Automobilindustrie geeigneten Dichtmaterial abdichten.
- Schrauben über Kreuz anziehen und nicht über eine Kraft von ca. 6-8 Nm hinaus anziehen. Verwenden Sie einen Handschraubendreher oder stellen Sie die Kupplung bei elektrischem Antrieb auf niedrig. Der Lautsprecher sollte gut festgezogen, aber nicht mit Gewalt befestigt werden. Gewaltwirkung könnte zu Rissen und/oder Verformungen im Korb führen.

Ständige Einwirkung übermäßiger Schalldruckpegel kann zu Gehörchäden führen. ESB empfiehlt dringend, dass Sie beim Einstellen der Lautstärke Ihren gesunden Menschenverstand walten lassen. Alle Angaben in diesem Handbuch dienen der ordnungsgemäßen Verwendung der Produkte. Einige Funktionen oder Spezifikationen können während der Produktion geändert werden, um die Produktleistung zu verbessern. Die hier genannten technischen Spezifikationen und Funktionalitäten entsprechen dem Stand zum Zeitpunkt der Veröffentlichung.

## FR Instructions Générales

L'installation du produit doit être effectuée par des techniciens professionnels. Contactez tous jours un Revendeur agréé ESB.

Merci d'avoir acheté vos nouveaux haut-parleurs ESB. S'ils sont correctement installés, ils vous offriront des années d'expérience audio exceptionnelle. Bien que nous ayons essayé de nous assurer que toutes les informations contenues ici soient exactes, veuillez noter que les instructions suivantes doivent être utilisées uniquement à titre indicatif. Si vous n'êtes pas sûr de pouvoir effectuer l'une des procédures répertoriées ci-dessous, veuillez contacter un centre d'installation audio automobile professionnelle. Avant et pendant l'installation, veuillez suivre ces directives :

- Pour des raisons de sécurité, débranchez toujours la borne négative de la batterie avant de commencer l'installation.
- Utilisez des connecteurs de la plus haute qualité pour une installation fiable et pour minimiser la perte de signal ou de puissance.
- Soyez prudent avant de percer ou de couper. Faites attention de ne pas couper ou percer les réservoirs d'essence, les conduites de carburant, les conduites de frein ou hydrauliques, les conduites d'aspiration ou le câblage électrique lorsque vous travaillez sur un véhicule. Avant de percer ou de couper, vérifiez le dessous de la zone de travail.
- Ne faites jamais passer les fils des haut-parleurs sous votre véhicule. Le passage des câbles de haut-parleur à l'intérieur du véhicule offre la meilleure protection contre la chaleur des gaz d'échappement et les éléments environnementaux.
- Évitez de faire passer les câbles sur, à proximité ou à travers des surfaces à bords tranchants. Utilisez des œillets en caoutchouc pour protéger tous les fils achématisés à travers le métal.
- Lorsque vous faites passer le câble pour haut-parleurs depuis l'amplificateur, évitez de le faire passer à proximité de sources de courant élevé (c'est-à-dire des faisceaux de câbles, des câbles de batterie).
- Faites attention à la polarité positive et négative des haut-parleurs. Dans certains véhicules, il peut être possible d'utiliser le câblage des haut-parleurs existant. Ce faisant, faites attention à la polarité (+/-) des fils de ces haut-parleurs, car ces couleurs de fils varient pour chaque véhicule. Dans certains véhicules, il peut être nécessaire de faire passer un nouveau fil de haut-parleur dans tout le véhicule.
- Ne laissez jamais les câbles toucher une partie métallique de la voiture et veillez à ce que les bornes des haut-parleurs soient correctement éloignées des pièces métalliques et si besoin protégés par un isolant électrique.
- Assurez-vous que chaque haut-parleur repose sur une surface bien plane, utilisez le joint en mousse fourni. Les fuites d'air entraineront une forte dégradation de la qualité sonore. Scellez toute fuite d'air avec un matériau d'étanchéité de qualité automobile.
- Serrez les vis en diagonale et ne serrez pas au-delà d'une force d'environ 6 à 8 Nm. Utilisez un tournevis à main ou, s'il est électrique, réglez l'embrayage au minimum. Le haut-parleur doit être bien serré, mais sans forcer. Forcer pourrait provoquer des fissures et/ou des déformations du panier voir même la rupture du panier du haut-parleur.

Une exposition continue à des niveaux de pression sonore excessifs peut provoquer des lésions auditives. ESB vous conseille fortement de faire preuve de bon sens lors du réglage des niveaux de volume. Tout ce qui est écrit dans ce manuel est destiné à la bonne utilisation des produits. Certaines caractéristiques ou spécifications pourraient être modifiées en cours de production pour améliorer les performances du produit. Les spécifications techniques et les fonctionnalités indiquées ici sont à jour au moment de la publication.

## ES Instrucciones Generales

La instalación del producto debe ser realizada por técnicos profesionales. Comuníquese siempre con un Distribuidor Autorizado ESB.

Gracias por comprar sus nuevos altoparlantes ESB. Si se instalan correctamente, le brindarán años de excelente experiencia de audio. Aunque hemos intentado asegurarnos de que toda la información contenida aquí sea precisa, tenga en cuenta que las siguientes instrucciones deben utilizarse únicamente como guía general. Si no está seguro de realizar alguno de los procedimientos que se enumeran a continuación, comuníquese con un centro de instalación de audio para automóvil profesional.

- Antes y durante la instalación, siga estas pautas:
  - Por seguridad, siempre desconecte el terminal negativo de la batería antes de comenzar la instalación.
- Utilice conectores de la más alta calidad para una instalación confiable y para minimizar la pérdida de señal o energía.
- Tenga cuidado antes de taladrar o cortar. Tenga cuidado de no cortar ni perforar tanques de gasolina, líneas de combustible, líneas de frenos o hidráulicas, líneas de vacío o cableado eléctrico cuando trabaje en cualquier vehículo. Antes de taladrar o cortar, revise la parte inferior del área de trabajo.
- Nunca pase cables de altavoz debajo de su vehículo. Colocar cables de altavoz dentro del vehículo proporciona la mejor protección contra el calor del escape y los elementos ambientales.
- Evite pasar cables sobre, cerca o a través de superficies con bordes afilados. Utilice arandelas de goma para proteger los cables que pasan a través del metal.
- Cuando pase el cable del altavoz desde el amplificador, evite pasarlo cerca de fuentes de alta corriente (es decir, conjunto de cables, cables de batería).
- Preste atención a la polaridad positiva y negativa del altavoz. En algunos vehículos, es posible utilizar el cableado de los altavoces existentes. Al hacer esto, tenga cuidado con la polaridad (+/-) de los cables de los altavoces, ya que los colores de estos cables varían para cada vehículo. En algunos vehículos, puede ser necesario instalar un cable de altavoz nuevo por todo el vehículo.
- Nunca deje que los cables toquen alguna parte metálica del automóvil y cuide que las terminales de los altavoces estén adecuadamente alejados de las partes metálicas.
- Asegúrese de que el altavoz descansa sobre una superficie plana y uniforme; utilice la junta de espuma proporcionada para que asiente correctamente. Las fugas de aire provocarán una grave degradación de la calidad del sonido. Selle cualquier fuga de aire con un material sellador de calidad automotriz.
- Apriete los tornillos en diagonal y no los apriete más allá de una fuerza de aproximadamente 6-8 Nm. Utilice un destornillador manual o, si es eléctrico, ajuste el embrague a velocidad baja y con la fuerza especificada. El altavoz debe quedar bien apretado, pero no forzado. Forzar podría causar grietas y/o deformación de la canasta o que se rompa.

La exposición continua a niveles excesivos de presión sonora puede causar daños auditivos. ESB recomienda encarecidamente que utilice el sentido común al configurar los niveles de volumen. Todo lo escrito en este manual es para el uso adecuado de los productos. Algunas características o especificaciones podrían modificarse durante la producción para mejorar el rendimiento del producto. Las especificaciones técnicas y las funcionalidades aquí indicadas están actualizadas en el momento de la publicación.

## CH 常规安装指引

产品的安装必须由熟练的技术人员完成。请始终联系 ESB 授权经销商。

感谢您购买这款全新的ESB汽车扬声器。如果安装无误，它将在未来为您带来极致的音乐体验。尽管我们已经尽力确保以下包含的所有信息准确无误，但仍请留意以下操作建议仅供参考。如果您对执行以下的安装准则存在任何疑虑，请务必联系专业的汽车音响安装中心。

- 在安装前和安装过程中，请遵循以下准则：
- 为了安全起见，在开始安装之前请断开电池的负极端。
  - 使用最高质量的连接器进行安装，以尽量减少信号或功率损失。
  - 在钻孔或切割之前要小心。在任何车辆上工作时，请小心不要切割或钻孔进入油箱、燃油管、制动管道、液压管道、真空管道或电气线路。在钻孔或切割之前请务必检查工作区域的底部。
  - 严禁将扬声器线路布置在车辆底盘上。将扬声器线路布置在车内可对线材提供最佳的保护，以防止排气和外部环境因素对其造成的不利影响。
  - 避免将线材布置在锋利的表面上。使用橡胶垫圈来保护需穿过金属表面的线材。
  - 将功率放大器与扬声器连接时，避免将其布线靠近高强度电流源（例如配线束、电池电缆）。
  - 注意扬声器的正负极性。部分车型可使用现有的扬声器线束。在这种情况下，请注意扬声器线的极性 (+/-)，因为不同车型的扬声器线束颜色会有差异。而对于某些车型，用户可能需要更换全套扬声器线束。
  - 永远不要让电缆触及汽车的任何金属部分，并确保扬声器端子远离金属部件。
  - 确保扬声器放置在平坦均匀的重表面上，并使用配套的垫圈。气密性不佳会严重影响声音质量，建议使用汽车级密封材料，以确保最佳的气密性。
  - 建议使用手动螺丝刀对角紧螺丝，并不要超过6–8 Nm的力。若使用电动螺丝刀，请将扭力调至低档。扬声器应该适度拧紧，但螺丝过紧可能会导致扬声器支架裂纹和/或变形。
  - 持续暴露于过高的声压级可能会导致听力损伤。ESB强烈建议在设置音量水平时要注意保护听力。本手册中的所有内容都是为了正确使用产品而编写的。一些功能或规格可能会在生产过程中进行修改以提高产品性能。此处所述的技术规格和功能截至出版时间为准。

长时间暴露于过高的声压级可能会导致听力损伤。ESB强烈建议在设置音量水平时要注意保护听力。本手册中的所有内容都是为了正确使用产品而编写的。一些功能或规格可能会在生产过程中进行修改以提高产品性能。此处所述的技术规格和功能仅针对本手册出版日期前的功放机产品。

# 9.1T-25

## Part List

- 1 2 x 9.1T-25
- 2 2 x Grille
- 3 2 x Cup
- 4 2 x Spring
- 5 2 x Honda Adaptor
- 6 2 x VW 1 Adaptor
- 7 2 x VW 2 Adaptor
- 8 2 x BMW 1 Adaptor
- 9 2 x AUDI 1 Adaptor
- 10 2 x AUDI 2 Adaptor
- 11 2 x M4 Double Thread Pin
- 12 2 x M4x12 Screw
- 13 6 x 2.5x8 Screw
- 14 2 x 4 mm Washer
- 15 2 x M4 Nut
- 16 2 x 2.5 mm Hallen L-Key
- 17 2 x 2 mm Torx L-Key

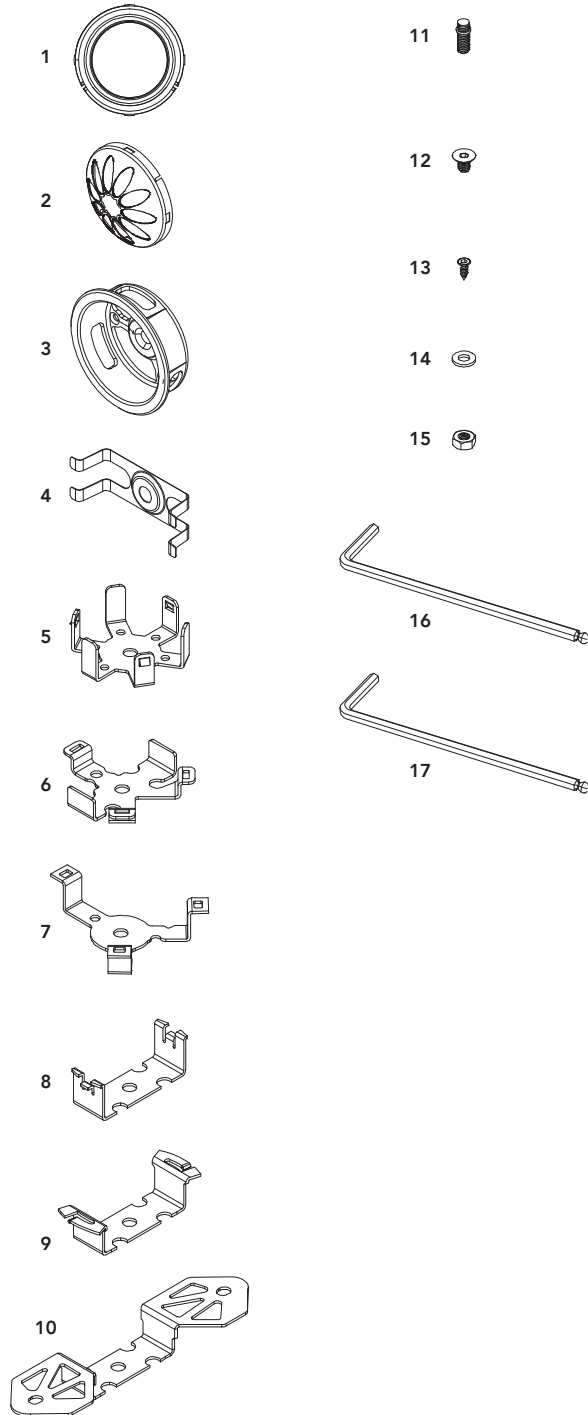

## Installation

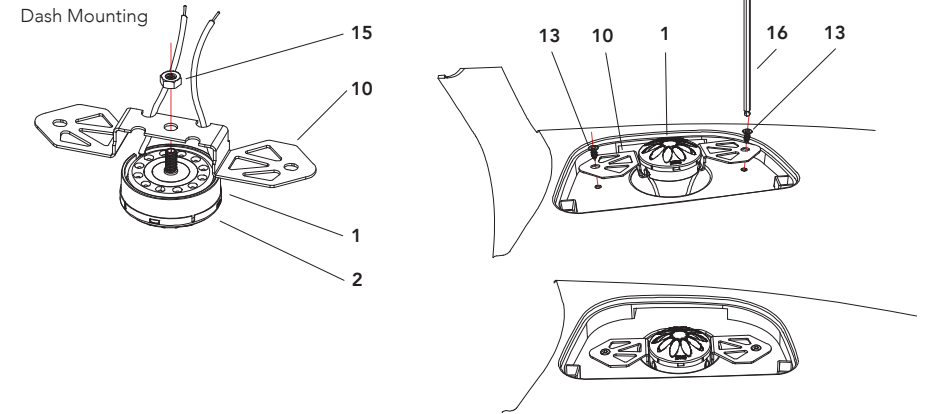
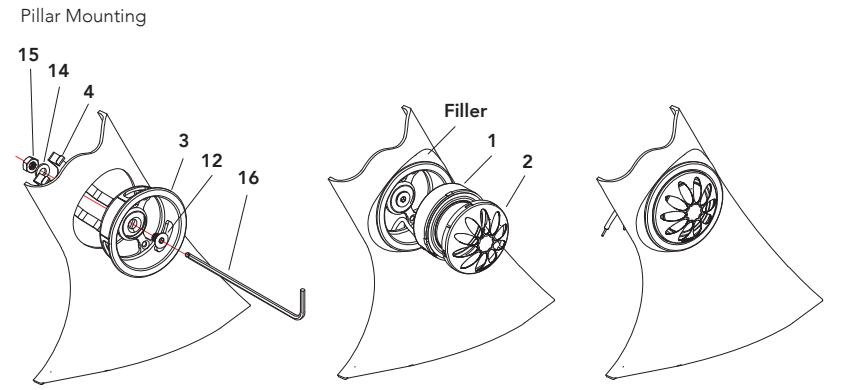
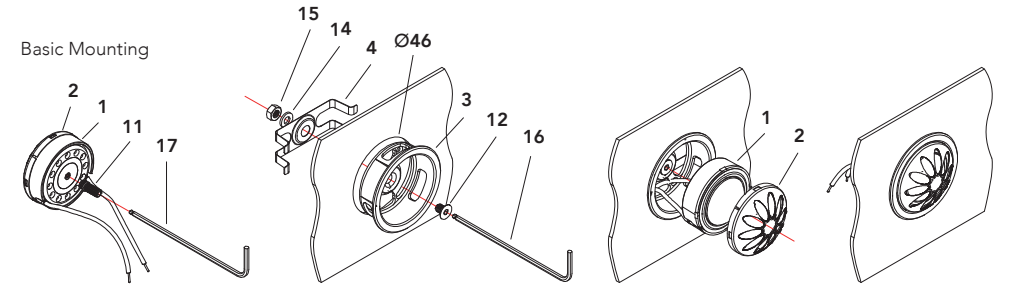

# 9.1T-28

## Part List

- 1 2 x 9.1T-28
- 2 2 x Fixing Ring
- 3 2 x Housing
- 4 2 x Back Cover
- 5 2 x Finishing Ring
- 6 2 x Damper
- 7 1 x Ring Tool
- 8 2 x Support
- 9 5 x M3x5 Screw
- 10 5 x M3x5 Screw
- 11 5 x 3x19 Screw
- 12 5 x 3x22 Screw
- 13 5 x M3x22 Screw
- 14 2 x 2.5 mm Hallen L-Key
- 15 2 x 2 mm Torx L-Key



1



2

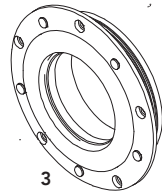

3

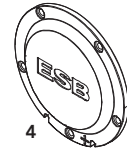

4

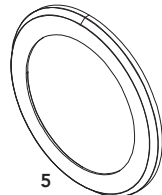

5



6

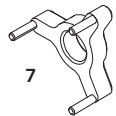

7



8



9



10



11



12



13

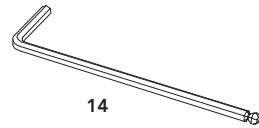

14

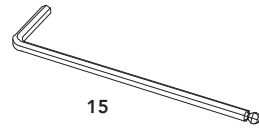

15

## Installation

### Hole Marking

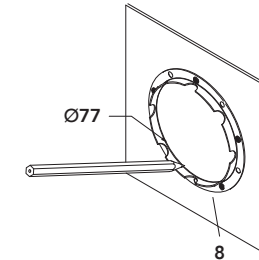
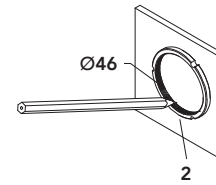

### Basic Mounting

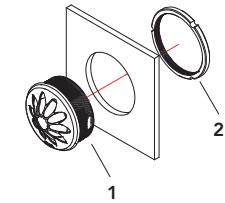

### Housing Mounting

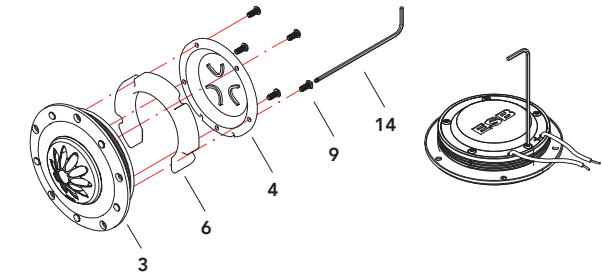
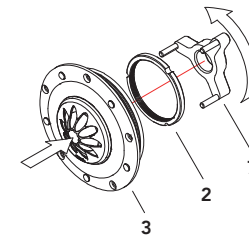

### Tweeter + Housing Mounting with Support

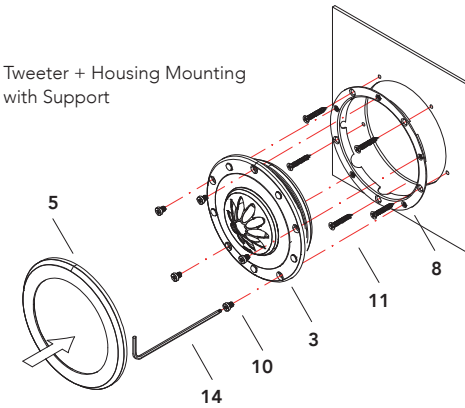

### Tweeter + Housing Mounting without Support

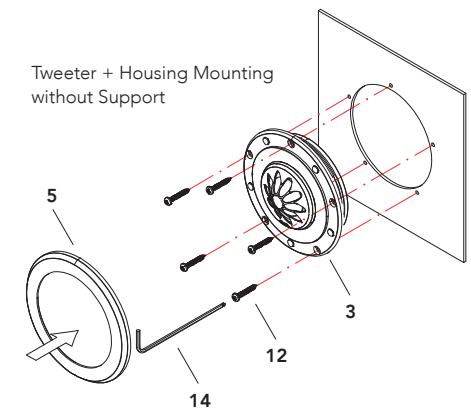

### Tweeter + Housing Mounting with Support from back

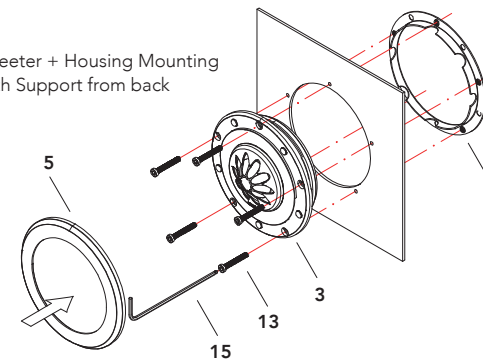

# 9.UMA

## Part List

- 1 2 x 9.UMA
- 2 2 x Foam Gasket
- 3 8 x Ø3x14 Screw
- 4 2 x 2.5 mm Hallen L-Key
- 5 2 x 2 mm Hallen L-Key
- 6 Butyl Rubber Sealant

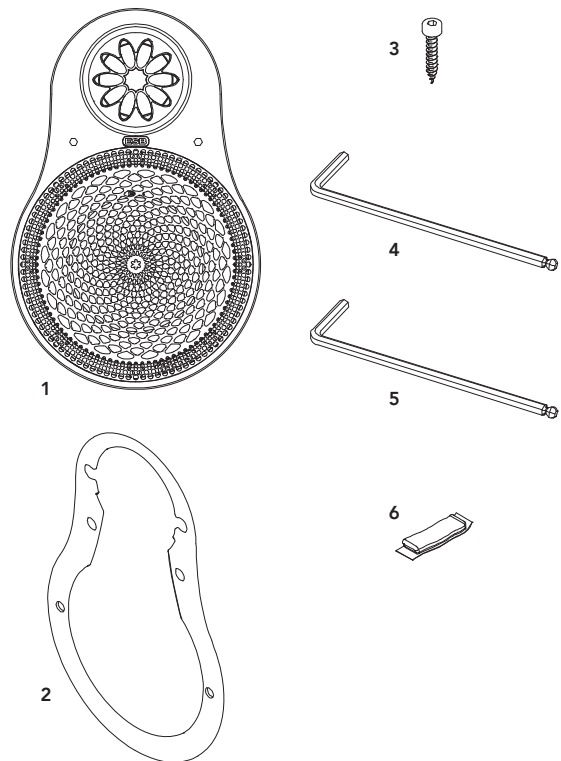

## Installation

### Hole Marking

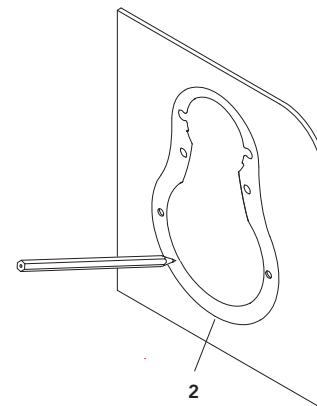

### Basic Mounting

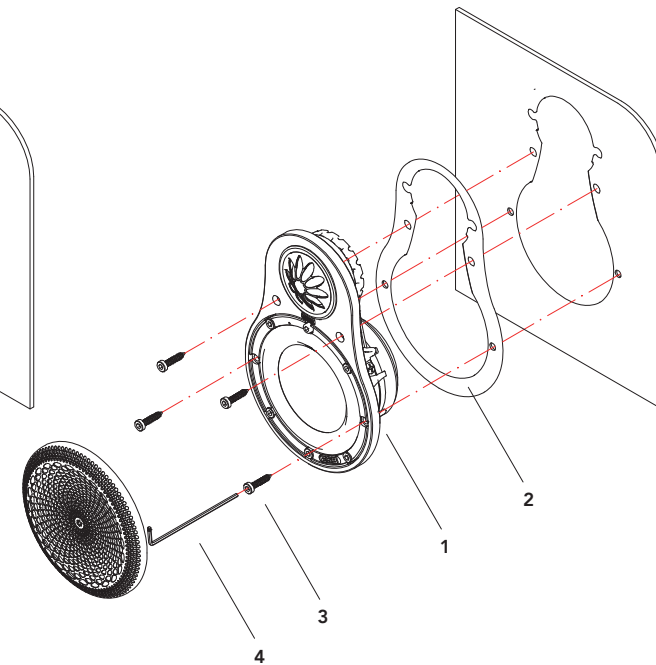

Grille mounting. Use small pieces of butyl rubber (6) inside vertical edge of ring

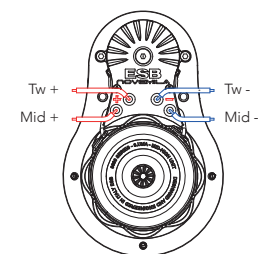
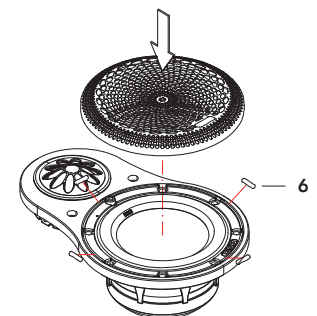

Peel min 5 max 10mm

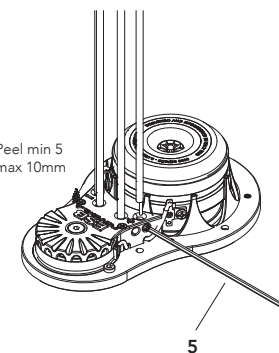

# 9.3M

## Part List

- 1 2 x 9.3M
- 2 2 x Grille Ring
- 3 2 x Grille
- 4 2 x Foam Gasket
- 5 8 x Ø3x5 Screw
- 6 2 x 2.5 mm Hallen L-Key
- 7 7 x 255 mm PVC

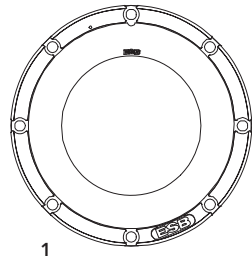

1



5

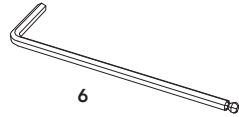

6

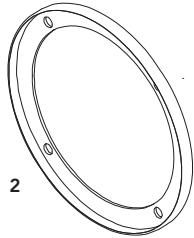

2

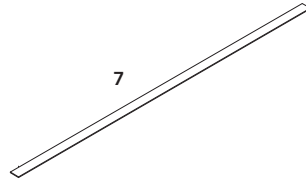

7

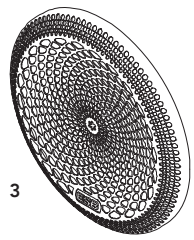

3

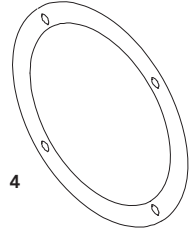

4

## Installation

How to center the Grille Ring

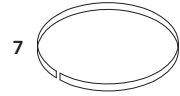

7

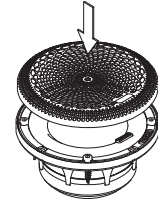
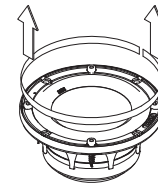
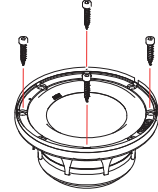
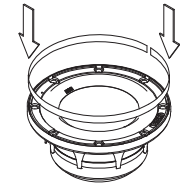
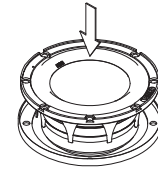

Hole Marking

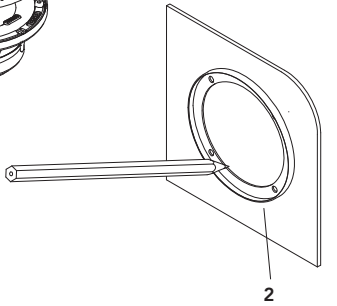

2

Midrange + Grille Mounting

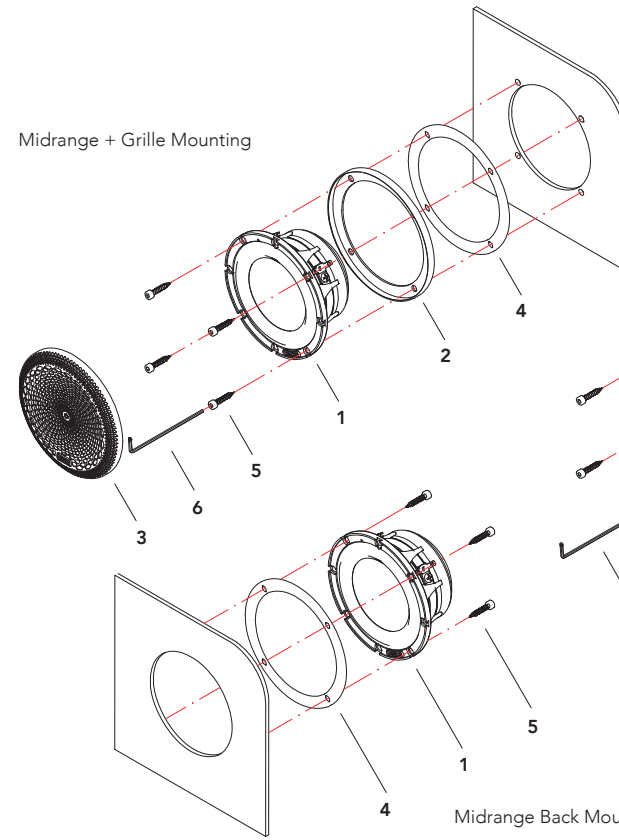

Midrange without Grille Mounting

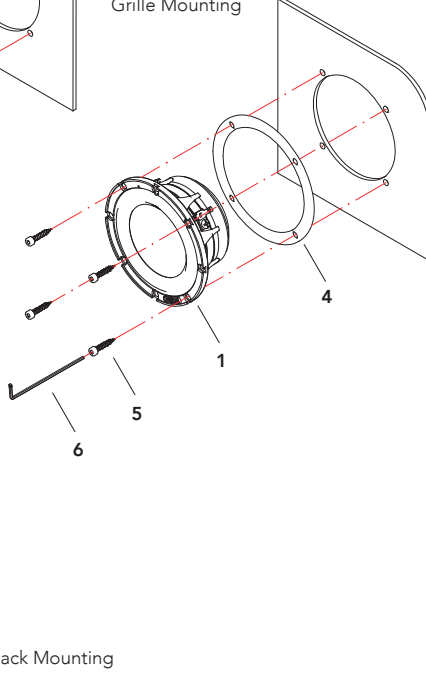

Midrange Back Mounting

# 9.4M

## Part List

- 1 2 x 9.4M
- 2 2 x Grille Ring
- 3 2 x Grille
- 4 2 x Foam Gasket
- 5 8 x Ø3x16 Screw
- 6 2 x 1.5 mm Hallen L-Key
- 7 2 x 2.5 mm Hallen L-Key
- 8 Butyl Rubber Sealant

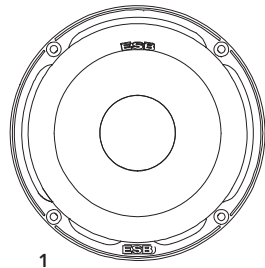

1

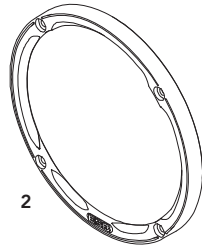

2

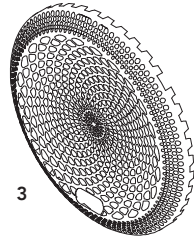

3

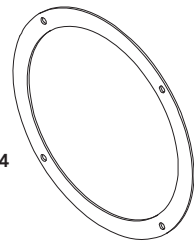

4



5



6

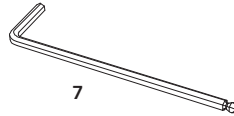

7



8

## Installation

Grille mounting. Use small pieces of butylic rubber (8) inside vertical edge of ring (2)

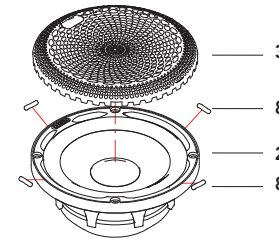

Peel min 5 max 10mm

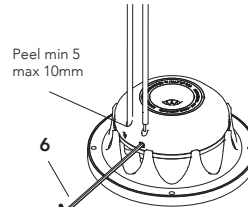

Hole Marking

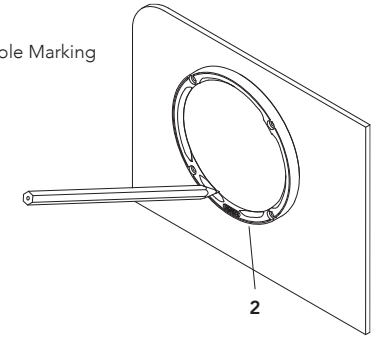

Midrange + Grille Mounting

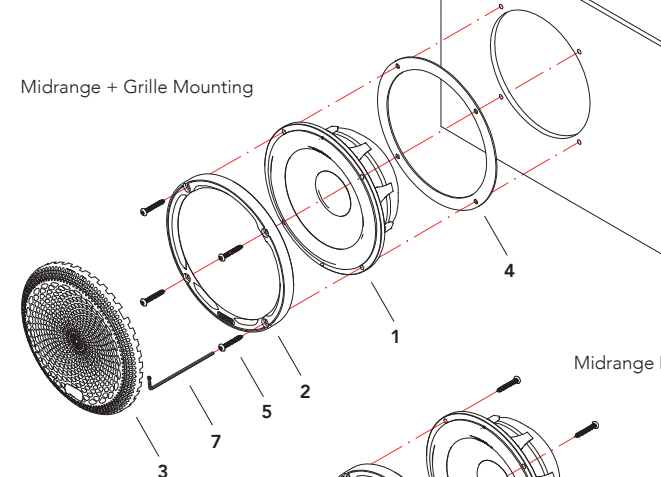

Midrange Back Mounting

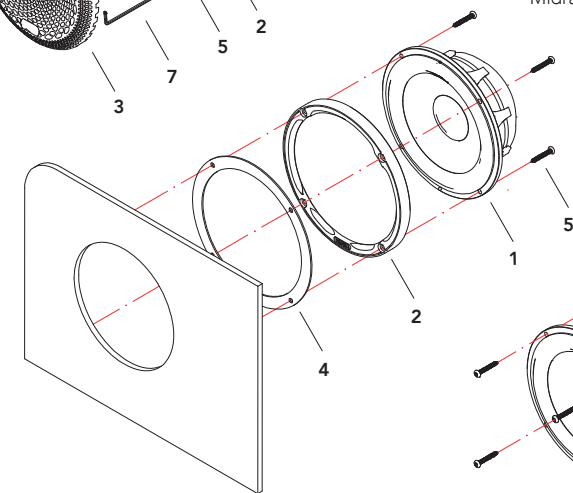

Midrange without Grille Mounting

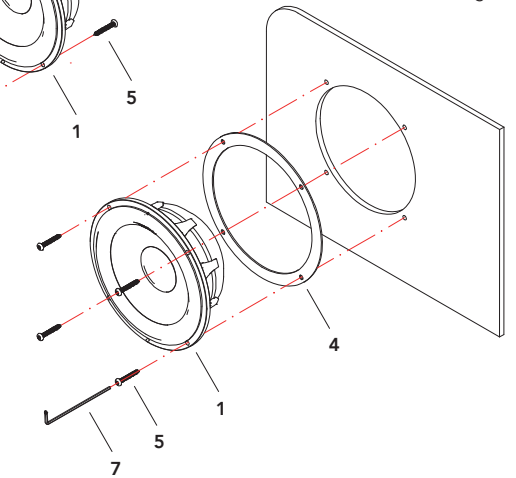



# 9.6W

## Part List

- 1 2 x 9.6W
- 2 2 x Finishing Ring
- 3 2 x Grille
- 4 2 x Grille Ring
- 5 2 x Foam Gasket
- 6 8 x Ø3.5x20 Screw
- 7 2 x 2 mm Hallen L-Key
- 8 2 x 3 mm Hallen L-Key
- 9 1 x Grill Removal Tool

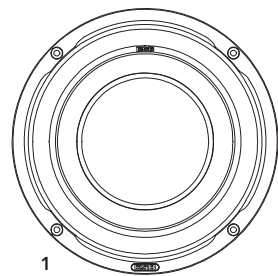

1

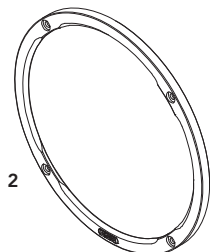

2

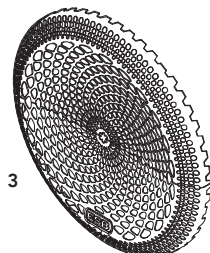

3

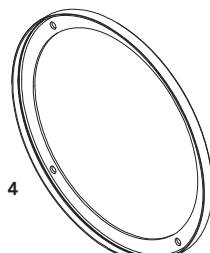

4

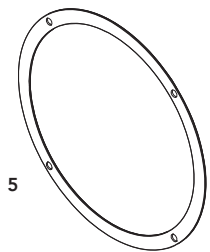

5



6



7

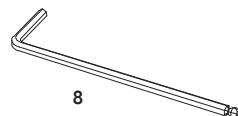

8



9

## Installation

Grille removal. Insert and twist the tool, then pull upwards

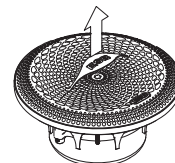
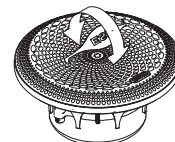

Peel min 5 max 10mm

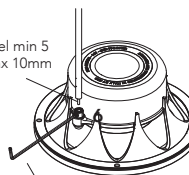

7

Hole Marking

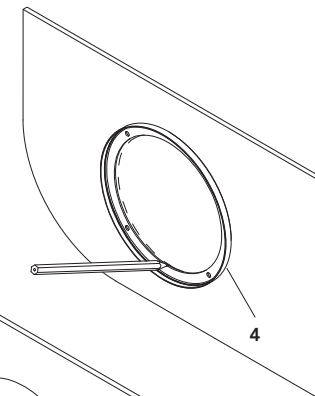

4

Woofer + Grille Mounting

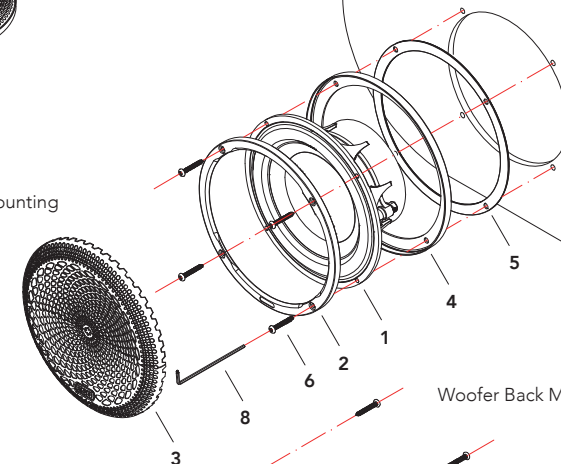

3

Woofer Back Mounting

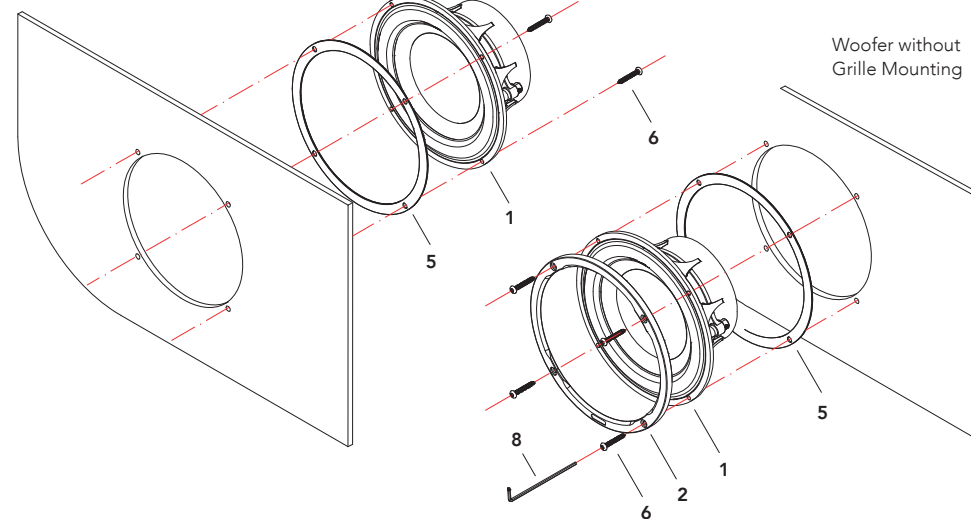

Woofer without Grille Mounting

6

2

1

5

# Technical Specifications

## 9.1T-25

Speaker Type: Component Tweeter  
Nominal Diameter: 1"/25 mm  
Nominal Impedance (Znom): 4 Ohms  
Continuous Power Handling: 100 W  
Peak Power Handling: 200 W  
Rec. Amplifier Power: 40 - 150W (RMS)

### Parameters

Voice Coil Resistance (Re): 3.8 Ohms  
Free Air Resonance (Fs): 1.25 KHz  
Sensitivity: 91.5 dB @ 2.83v/1m  
88.5 dB @ 1W/1m  
Electrical "Q" (Qes): 3.053  
Mechanical "Q" (Qms): 1.874  
Total Speaker "Q" (Qts): 1.116

### Design Bandwidth

With 48 dB/oct. HP filters:  
1.6 KHz - 25 KHz  
With 24 dB/oct. HP filters:  
1.9 KHz - 25 KHz  
With 12 dB/oct. HP filters:  
2.2 KHz - 25 KHz

## 9.1T-28

Speaker Type: Component Tweeter  
Nominal Diameter: 1.1"/28 mm  
Nominal Impedance (Znom): 4 Ohms  
Continuous Power Handling: 110 W  
Peak Power Handling: 220 W  
Rec. Amplifier Power: 50 - 170W (RMS)

### Parameters

Voice Coil Resistance (Re): 3.8 Ohms  
Free Air Resonance (Fs): 900 Hz  
Sensitivity: 94.5 dB @ 2.83v/1m  
91.5 dB @ 1W/1m  
Electrical "Q" (Qes): 1.217  
Mechanical "Q" (Qms): 1.903  
Total Speaker "Q" (Qts): 0.742

### Design Bandwidth

With 48 dB/oct. HP filters:  
1.5 KHz - 25 KHz  
With 24 dB/oct. HP filters:  
1.8 KHz - 25 KHz  
With 12 dB/oct. HP filters:  
2 KHz - 25 KHz

## 9.UMA

Speaker Type: Component Tweeter  
Nominal Diameter: 1"/25 mm  
Nominal Impedance (Znom): 4 Ohms  
Continuous Power Handling: 100 W  
Peak Power Handling: 200 W  
Rec. Amplifier Power: 40 - 150W (RMS)

### Parameters

Voice Coil Resistance (Re): 3.8 Ohms  
Free Air Resonance (Fs): 1.25 KHz  
Sensitivity: 91.5 dB @ 2.83v/1m  
88.5 dB @ 1W/1m  
Electrical "Q" (Qes): 3.053  
Mechanical "Q" (Qms): 1.874  
Total Speaker "Q" (Qts): 1.116

### Design Bandwidth

With 48 dB/oct. HP filters:  
1.6 KHz - 25 KHz  
With 24 dB/oct. HP filters:  
1.9 KHz - 25 KHz  
With 12 dB/oct. HP filters:  
2.2 KHz - 25 KHz

Speaker Type: Component Midrange  
Nominal Diameter: 3"/75 mm  
Nominal Impedance (Znom): 4 Ohms  
Continuous Power Handling: 100 W  
Peak Power Handling: 220 W  
Rec. Amplifier Power: 40 - 150W (RMS)  
Driver Rear Displacement: 0.12 lt  
Min. Rec. Sealed Enclosure: 0.6 lt

### Parameters

Voice Coil Resistance (Re): 3.6 Ohms  
Free Air Resonance (Fs): 125 Hz  
Reference Efficiency (no): 0.422 %  
Sensitivity: 91.5 dB @ 2.83v/1m  
88.5 dB @ 1W/1m  
Electrical "Q" (Qes): 0.355  
Mechanical "Q" (Qms): 11.364  
Total Speaker "Q" (Qts): 0.344  
Equivalent Compliance (Vas): 0.7 lt  
Moving Mass (Mms): 2.8 g  
Mech. Compliance (Cms): 0.000540 m/N  
Magnetic Strength (BL): 4.841 N/A  
Effective Piston Area (Sd): 31.1 sq. cm.  
One-Way Linear Excursion (Xmax): 2.8 mm

### Design Bandwidth

With 48 dB/oct. HP filters:  
100 Hz - 20 KHz  
With 24 dB/oct. HP filters:  
120 Hz - 20 KHz  
With 12 dB/oct. HP filters:  
140 Hz - 20 KHz

## 9.3M

Speaker Type: Component Midrange  
Nominal Diameter: 3"/75 mm  
Nominal Impedance (Znom): 4 Ohms  
Continuous Power Handling: 100 W  
Peak Power Handling: 220 W  
Rec. Amplifier Power: 40 - 150W (RMS)  
Driver Rear Displacement: 0.12 lt  
Min. Rec. Sealed Enclosure: 0.6 lt

### Parameters

Voice Coil Resistance (Re): 3.6 Ohms  
Free Air Resonance (Fs): 125 Hz  
Reference Efficiency (no): 0.422 %  
Sensitivity: 91.5 dB @ 2.83v/1m  
88.5 dB @ 1W/1m  
Electrical "Q" (Qes): 0.355  
Mechanical "Q" (Qms): 11.364  
Total Speaker "Q" (Qts): 0.344  
Equivalent Compliance (Vas): 0.7 lt  
Moving Mass (Mms): 2.8 g  
Mech. Compliance (Cms): 0.000540 m/N  
Magnetic Strength (BL): 4.841 N/A  
Effective Piston Area (Sd): 31.1 sq. cm.  
One-Way Linear Excursion (Xmax): 2.8 mm

### Design Bandwidth

With 48 dB/oct. HP filters:  
100 Hz - 20 KHz  
With 24 dB/oct. HP filters:  
120 Hz - 20 KHz  
With 12 dB/oct. HP filters:  
140 Hz - 20 KHz

## 9.4M

Speaker Type: Component Midrange  
Nominal Diameter: 4"/100 mm  
Nominal Impedance (Znom): 4 Ohms  
Continuous Power Handling: 120 W  
Peak Power Handling: 240 W  
Rec. Amplifier Power: 50 - 200W (RMS)  
Driver Rear Displacement: 0.14 lt  
Min. Rec. Sealed Enclosure: 1 lt

### Parameters

Voice Coil Resistance (Re): 4.1 Ohms  
Free Air Resonance (Fs): 135 Hz  
Reference Efficiency (no): 0.359 %  
Sensitivity: 90.6 dB @ 2.83v/1m  
87.6 dB @ 1W/1m  
Electrical "Q" (Qes): 0.931  
Mechanical "Q" (Qms): 3.645  
Total Speaker "Q" (Qts): 0.741  
Equivalent Compliance (Vas): 1.4 liters.  
Moving Mass (Mms): 4.5 g  
Mech. Compliance (Cms): 0.000306 m/N  
Magnetic Strength (BL): 4.117 N/A  
Effective Piston Area (Sd): 56.7 sq. cm.  
One-Way Linear Excursion (Xmax): 2.8 mm

### Design Bandwidth

With 48 dB/oct. HP filters:  
100 Hz - 20 KHz  
With 24 dB/oct. HP filters:  
120 Hz - 20 KHz  
With 12 dB/oct. HP filters:  
140 Hz - 20 KHz

## 9.6W

Speaker Type: Component Mid-Woofer  
Nominal Diameter: 6.5"/165 mm  
Nominal Impedance (Znom): 4 Ohms  
Continuous Power Handling: 180 W  
Peak Power Handling: 360 W  
Rec. Amplifier Power: 75 - 300W (RMS)  
Driver Rear Displacement: 0.5 lt  
Min. Rec. Sealed Enclosure: 11 lt

### Parameters

Voice Coil Resistance (Re): 3.6 Ohms  
Free Air Resonance (Fs): 61.9 Hz  
Reference Efficiency (no): 0.427 %  
Sensitivity: 91.5 dB @ 2.83v/1m  
88.5 dB @ 1W/1m  
Electrical "Q" (Qes): 0.569  
Mechanical "Q" (Qms): 2.202  
Total Speaker "Q" (Qts): 0.452  
Equivalent Compliance (Vas): 10.5 lt  
Moving Mass (Mms): 16.5 g  
Mech. Compliance (Cms): 0.000399 m/N  
Magnetic Strength (BL): 6.375 N/A  
Effective Piston Area (Sd): 136.2 sq. cm.  
One-Way Linear Excursion (Xmax): 5.25 mm

### Design Bandwidth

With 48 dB/oct. HP filters:  
50 Hz - 5 KHz  
With 24 dB/oct. HP filters:  
70 Hz - 5 KHz  
With 12 dB/oct. HP filters:  
80 Hz - 5 KHz

Tweeter

Midrange



**Designed and Engineered in Italy by ESB**

Distributed in Europe / Distribuito in Europa da:  
ARPA of Europe srl - Via Isonzo snc, 04100 Latina, Italia

**esbcar.com**

Manual v.1.0 - March 20, 2024

**ESB**  
**AUDIO**