

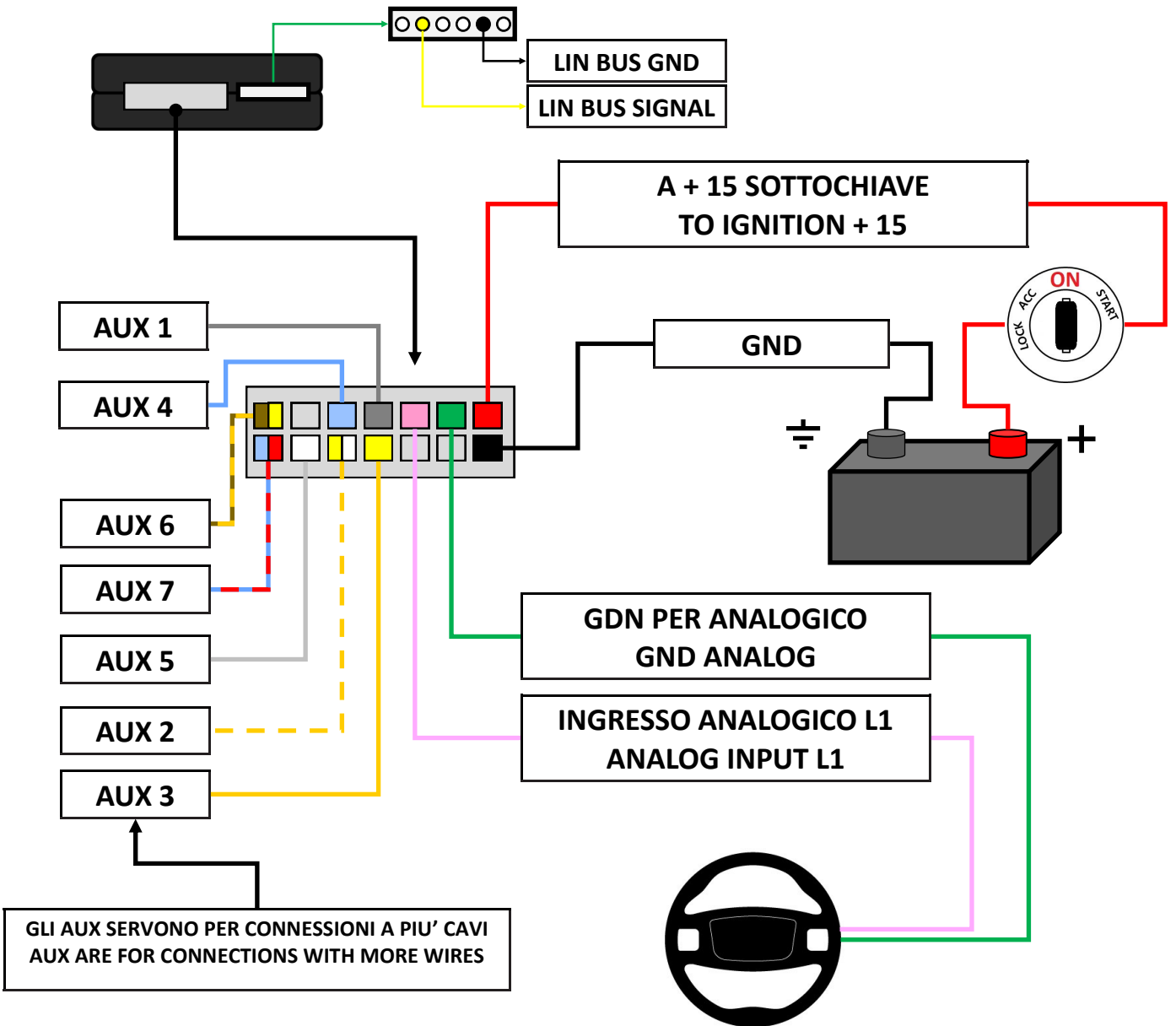

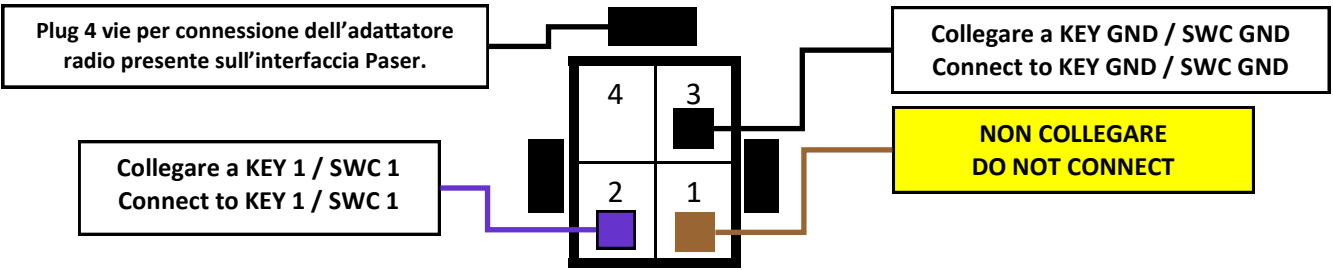









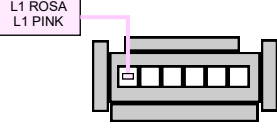

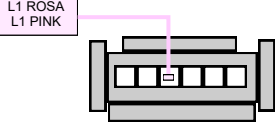

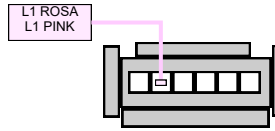

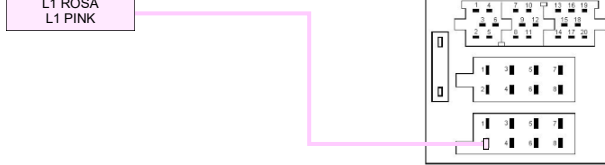

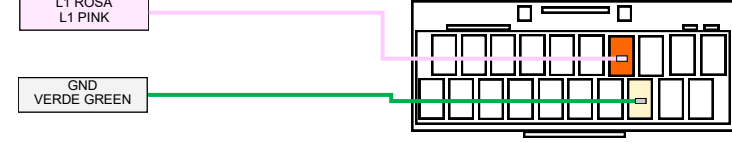

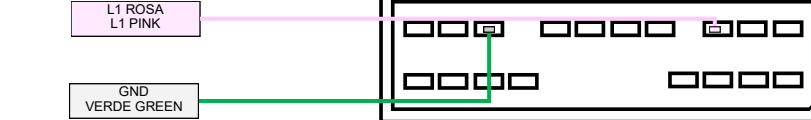

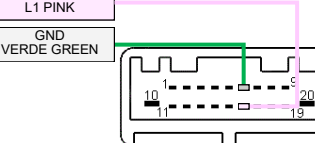

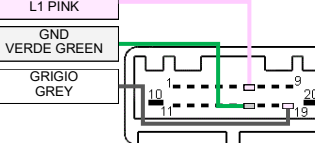

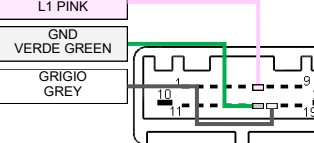

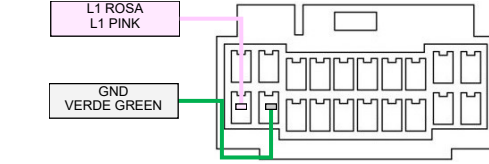

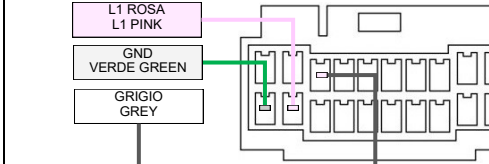

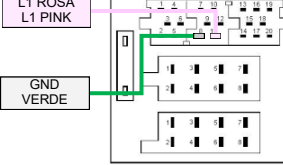
UNICOM EVO	DESCRIZIONE CABLAGGIO	CABLE DESCRIPTION
------------	-----------------------	-------------------

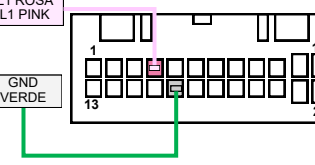

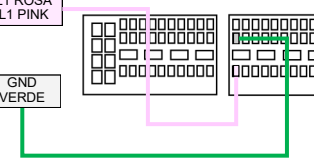
**CONNESSIONE A RADIO CON APPRENDIMENTO RESISTIVO - CONNECTIONS TO RADIO WITH RESISTIVE DIRECT MEMORIZING**

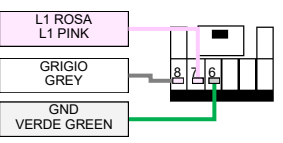

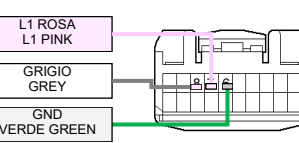
UNICOM EVO ANALOGUE		CONNESSIONI (VISTA CONNETTORI USCITA FILI) NON COLLEGARE I CAVI PRESENTI SUL CABLAGGIO NON CITATI NEGLI SCHEMI		CONNECTIONS (WIRES EXIT VIEW) DO NOT CONNECT WIRES PRESENT ON THE HARNESS BUT NOT MENTIONED IN THE DIAGRAMS	
<p><b>Panda</b> <b>Marea</b> <b>Barchetta</b></p>		<p><b>147 156 GT</b> <b>GTV</b> <b>DUCATO</b> <b>MULTIPLA</b></p>		<p><b>16</b></p>	
I CONNETTORI SONO NEL VANO RADIO			CONNECTORS ARE LOCATED IN THE RADIO SLOT		
<p><b>&gt;2002</b></p>		<p><b>&gt;2002</b></p>		<p><b>&gt;2002</b></p>	
I CONNETTORI SONO NEL VANO STERZO			CONNECTORS ARE LOCATED BELOW THE STEERING WHEEL		
<p><b>ISO</b></p>		<p><b>OEM</b></p>			
I CONNETTORI SONO NEL VANO RADIO			CONNECTORS ARE LOCATED IN THE RADIO SLOT		
<p><b>OLD</b></p>		<p><b>OEM</b></p>		<p><b>FAKRA</b></p>	
I CONNETTORI SONO NEL VANO RADIO			CONNECTORS ARE LOCATED IN THE RADIO SLOT		
<p><b>ISO</b></p>		<p><b>OEM &gt;2018</b></p>		<p><b>OEM 2019</b></p>	
I CONNETTORI SONO NEL VANO RADIO			CONNECTORS ARE LOCATED IN THE RADIO SLOT		
<p><b>PAJERO</b></p>		<p><b>OUTLANDER</b> <b>ASX</b> <b>LANCER</b></p>		<p><b>L200</b></p>	
I CONNETTORI SONO NEL VANO RADIO			CONNECTORS ARE LOCATED IN THE RADIO SLOT		
<p><b>S2000 (09)</b></p>		<p><b>ACCORD (08)</b> <b>INSIGHT (07)</b></p>		<p><b>FRV</b></p>	
I CONNETTORI SONO NEL VANO RADIO			CONNECTORS ARE LOCATED IN THE RADIO SLOT		
<p><b>CIVIC</b> <b>CRV</b> <b>JAZZ</b> <b>2007</b></p>					
I CONNETTORI SONO NEL VANO RADIO			CONNECTORS ARE LOCATED IN THE RADIO SLOT		
<p><b>ISO</b></p>		<p><b>JUKE</b> <b>QASHQAI</b> <b>XTRAIL</b></p>		<p><b>PATHFINDER</b></p>	
I CONNETTORI SONO NEL VANO RADIO			CONNECTORS ARE LOCATED IN THE RADIO SLOT		

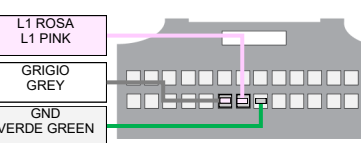
UNICOM EVO ANALOGUE	CONNESSIONI (VISTA CONNETTORI USCITA FILI) NON COLLEGARE I CAVI PRESENTI SUL CABLAGGIO NON CITATI NEGLI SCHEMI		CONNECTIONS (WIRES EXIT VIEW) DO NOT CONNECT WIRES PRESENT ON THE HARNESS BUT NOT MENTIONED IN THE DIAGRAMS		
  <b>GRAND CHEROKEE</b>	 L1 ROSA L1 PINK  INTERROMPERE FILO POSIZIONE 1 E COLLEGARE IL ROSA	  <b>CHEROKEE</b>	 L1 ROSA L1 PINK  INTERROMPERE FILO POSIZIONE 3 E COLLEGARE IL ROSA	  <b>VOYAGER</b>	 L1 ROSA L1 PINK  INTERROMPERE FILO POSIZIONE 2 E COLLEGARE IL ROSA
<b>I CONNETTORI SONO NEL SOTTO LO STERZO    CONNECTORS ARE LOCATED DOWN THE STEERING WHEEL</b>					
  <b>ISO</b>	 L1 ROSA L1 PINK				
<b>I CONNETTORI SONO NEL VANO RADIO    CONNECTORS ARE LOCATED IN THE RADIO SLOT</b>					
  <b>RANGE ROVER FREELANDER 2</b>	 L1 ROSA L1 PINK  GND VERDE GREEN				
<b>I CONNETTORI SONO NEL VANO RADIO    CONNECTORS ARE LOCATED IN THE RADIO SLOT</b>					
  <b>KYRON ACTYON KODANDO</b>	 L1 ROSA L1 PINK  GND VERDE GREEN				
<b>I CONNETTORI SONO NEL VANO RADIO    CONNECTORS ARE LOCATED IN THE RADIO SLOT</b>					
  <b>IMPREZA FORESTER OUTBACK</b>	 L1 ROSA L1 PINK  GND VERDE GREEN	  <b>OUTBACK LEGACY 2012</b>	 L1 ROSA L1 PINK  GND VERDE GREEN  GRIGIO GREY	  <b>IMPREZA FORESTER OUTBACK</b>	 L1 ROSA L1 PINK  GND VERDE GREEN  GRIGIO GREY
<b>I CONNETTORI SONO NEL VANO RADIO    CONNECTORS ARE LOCATED IN THE RADIO SLOT</b>					
  <b>SX4 GRAN VITARA SWIFT</b>	 L1 ROSA L1 PINK  GND VERDE GREEN		  <b>SX4 GRAN VITARA SWIFT</b>	 L1 ROSA L1 PINK  GND VERDE GREEN  GRIGIO GREY	
<b>I CONNETTORI SONO NEL VANO RADIO    CONNECTORS ARE LOCATED IN THE RADIO SLOT</b>					
  <b>ISO</b>	 L1 ROSA L1 PINK  GND VERDE	  <b>OEM &gt;2018</b>	 L1 ROSA L1 PINK  GND VERDE	  <b>OEM 2019</b>	 L1 ROSA L1 PINK  GND VERDE
<b>I CONNETTORI SONO NEL VANO RADIO    CONNECTORS ARE LOCATED IN THE RADIO SLOT</b>					
  <b>MODE 1</b>	 L1 ROSA L1 PINK  GRIGIO GREY  GND VERDE GREEN	  <b>MODE 2</b>	 L1 ROSA L1 PINK  GRIGIO GREY  GND VERDE GREEN	  <b>MODE 3</b>	 L1 ROSA L1 PINK  GRIGIO GREY  GND VERDE GREEN
<b>I CONNETTORI SONO NEL VANO RADIO    CONNECTORS ARE LOCATED IN THE RADIO SLOT</b>					

<b>UNICOM EVO ANALOGUE</b>	<b>CONNESSIONI</b> <b>(VISTA CONNETTORI USCITA FILI) NON COLLEGARE I CAVI</b> <b>PRESENTI SUL CABLAGGIO NON CITATI NEGLI SCHEMI</b>	<b>CONNECTIONS (WIRES EXIT VIEW) DO NOT CONNECT</b> <b>WIRES PRESENT ON THE HARNESS BUT</b> <b>NOT MENTIONED IN THE DIAGRAMS</b>
--------------------------------	---	--

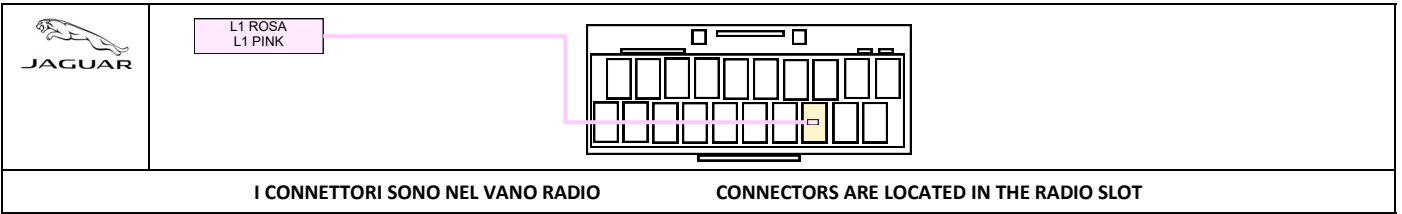
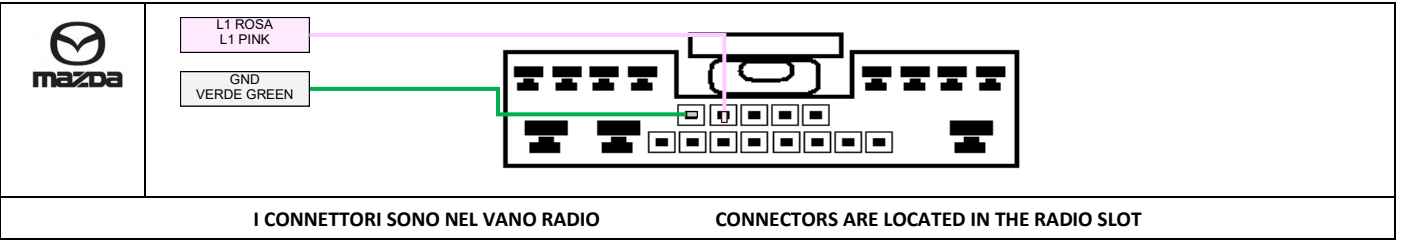

Le informazioni riportate in questo manuale e nei suoi allegati sono puramente a scopo informativo pertanto possono subire modifiche senza preavviso. Al momento della pubblicazione le informazioni risultano corrette ed attendibili. Tuttavia Paser non può essere ritenuta responsabile per eventuali conseguenze derivanti da errori, omissioni o incongruenze del presente manuale e dei suoi allegati (ad. es. per l'eventuale mancato recupero di configurazioni audio originali dei veicoli). Paser si riserva il diritto di migliorare/modificare il prodotto o il manuale senza l'obbligo di notifica agli utenti.

Information in this guide and its attachments are for information purposes only, therefore, they are subject to change without notice. At the time of publication the information is correct and reliable. However Paser can not be held responsible for any consequences resulting from errors, omissions or incongruence of this manual (for ex. missed audio configuration back-up of the vehicles). Paser reserves the right to improve / change the product or manual without obligation to notify users.