

# TSM 25 Mg 45

HIGH RESOLUTION TWEETER

- 25mm (1") Pur Magnesium dome tweeter
- High efficiency neodymium magnet N38
- High precision Machined Aluminium front plate
- Sound transparent protective grill



## TECHNICAL SPECIFICATIONS

<b>Component</b>	Tweeter	
<b>Max power</b>	100 W	
<b>Nominal power</b>	15 W	
<b>Impedance</b>	6 Ω	
<b>Freq. Response</b>	1.2 KHz - 23 KHz	
<b>Sensitivity (2,83V/1m)</b>	89 dB	
<b>Magnet</b>	Neodymium	
<b>Magnet size Ø x h</b>	24.5 x 3.5 mm	0.965" x 0.138"
<b>Total driver displacement</b>	-	-
<b>Weight of one component</b>	0.068 kg	0.150 lb
<b>Voice coil Ø</b>	25 mm	0.984"
<b>Voice coil height</b>	1.7 mm	0.067"
<b>Dome</b>	Magnesium	

Unit : mm

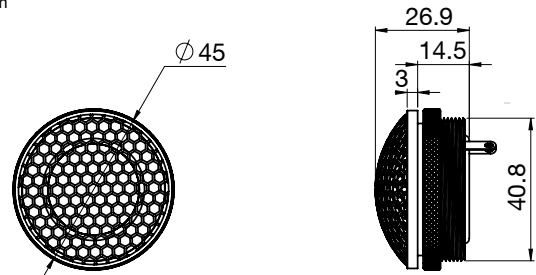

## FREQUENCY RESPONSE / IMPEDANCE

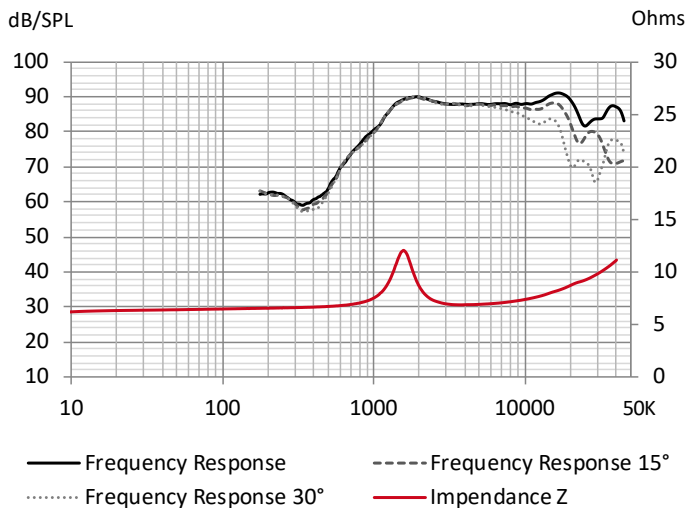

## THIELE-SMALL PARAMETERS

<b>Effective Ø (d)</b>	32 mm
<b>Sd</b>	8.04 cm <sup>2</sup>
<b>Xmax</b>	-
<b>Re</b>	6.1 Ω
<b>Fs</b>	1205 Hz
<b>Le</b>	-
<b>L2</b>	-
<b>Vas</b>	-
<b>Mms</b>	-
<b>Cms</b>	-
<b>BL</b>	-
<b>Qts</b>	-
<b>Qes</b>	-
<b>Qms</b>	-
<b>Sensitivity (dB/W/m)</b>	87.8 dB

## MS 3

### EXTENDED FREQUENCY SPEAKER

- Full-range driver 3" (80mm)
- Max. power: 100 W / Nom. power: 25 W
- Frequency response 120 Hz - 32 KHz
- Impedance 3 Ohms

Die cast aluminium basket - Ultra rigid carbon fiber cone - NBR surround - Long life «conex» spider - 20 mm Voice coil - Fiber glass former - Oversized neodymium Multi-Stick magnetic motor - Aluminium phase plug - Paired products to +/- 1dB.



Unit : mm

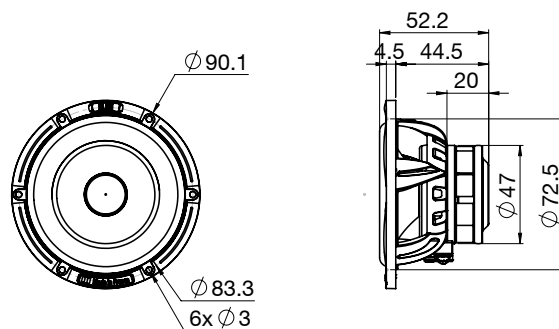

<b>Component</b>	Midrange	
<b>Max power</b>	100 W	
<b>Nominal power</b>	25 W	
<b>Impedance</b>	3 Ω	
<b>Freq. Response</b>	120 Hz - 32 KHz	
<b>Sensitivity (2,83V/1m)</b>	88 dB	
<b>Magnet</b>	Neodymium	
<b>Magnet size Ø x h</b>	8x 9 x 10 mm	8x 0.354" x 0,394"
<b>Total driver displacement</b>	0.060 l	0.002 cf
<b>Weight of one component</b>	0.328 kg	0.723 lb
<b>Voice coil Ø</b>	20 mm	0.787"
<b>Voice coil height</b>	6 mm	0.236"
<b>Cone</b>	Carbon fiber	

### FREQUENCY RESPONSE / IMPEDANCE

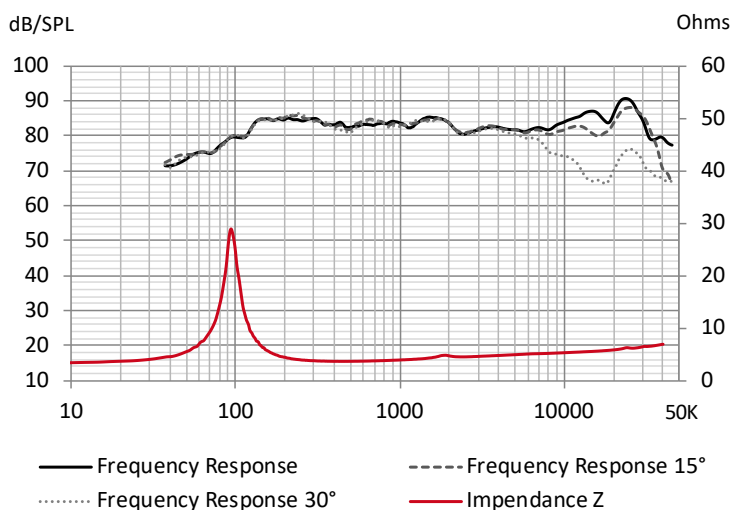

### THIELE-SMALL PARAMETERS

<b>Effective Ø (d)</b>	61 mm
<b>Sd</b>	29.22 cm <sup>2</sup>
<b>Xmax</b>	1 mm
<b>Re</b>	3.44 Ω
<b>Fs</b>	94.82 Hz
<b>Le</b>	16.11 μH @1 kHz
<b>L2</b>	186.90 μH @10 kHz
<b>Vas</b>	1.47 L
<b>Mms</b>	2.3 g
<b>Cms</b>	0.001227 m/N
<b>BL</b>	2.52 Tm
<b>Qts</b>	0.65
<b>Qes</b>	0.74
<b>Qms</b>	5.44
<b>Sensitivity (dB/W/m)</b>	84.1 dB

# Signature **Multix**

Guy Bonneville

**BLAM**  
DRIVEN BY PASSION

## WS 6

### HIGH POWER WOOFER

- Woofer 6-1/2 " (165 mm)
- Max power 250 W / Nom. power 125 W
- Frequency response 80 Hz - 6 KHz
- Impedance 2 Ohms

Die cast aluminium basket - Ultra rigid carbon fiber cone - NBR surround - Dual spider - 38 mm Voice Coil, fiber glass former - Oversized Neodymium Multi-Stick Magnetic motor - Machined aluminium phase plug - Gold-plated terminal - Paired products to +/- 1dB.

### TECHNICAL SPECIFICATIONS

Component	Woofer	
Max power	250 W	
Nominal power	125 W	
Impedance	2 Ω	
Freq. Response	80 Hz - 6 KHz	
Sensitivity (2,83V/1m)	94 dB	
Magnet	Neodymium	
Magnet size Ø x h	10x 15 x 17 mm	10x 0.591" x 0.669"
Total driver displacement	0.3 l	0.011 cf
Weight of one component	1.81 kg	3.990 lb
Voice coil Ø	38 mm	1.496"
Voice coil height	17 mm	0.669"
Cone	Carbon fiber	



Unit : mm

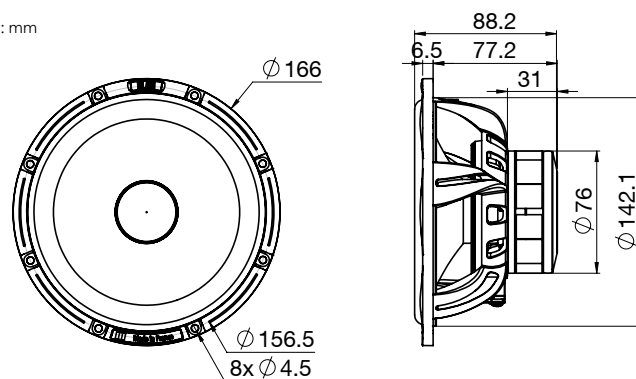

### FREQUENCY RESPONSE / IMPEDANCE

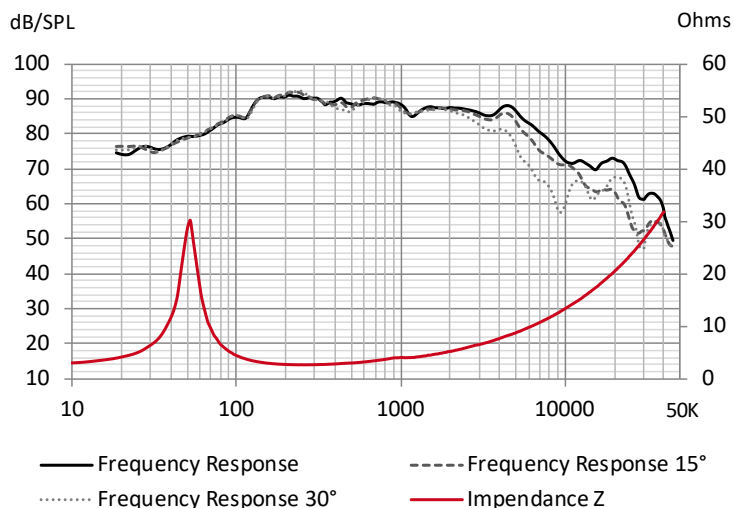

### THIELE-SMALL PARAMETERS

Effective Ø (d)	128 mm
Sd	128.68 cm <sup>2</sup>
Xmax	6 mm
Re	2.1 Ω
Fs	51.84 Hz
Le	100.07 µH @ 1 kHz
Le	263.46 µH @10 kHz
Vas	12.9 L
Mms	16.99 g
Cms	0,000555 m/N
BL	5.63 Tm
Qts	0.37
Qes	0.40
Qms	4.75
Sensitivity (dB/W/m)	88.1 dB

contact@blam-audio.fr  
www.facebook.com/blamaudio

blam-audio.com