

28 cm Subwoofer

28W/4878T00

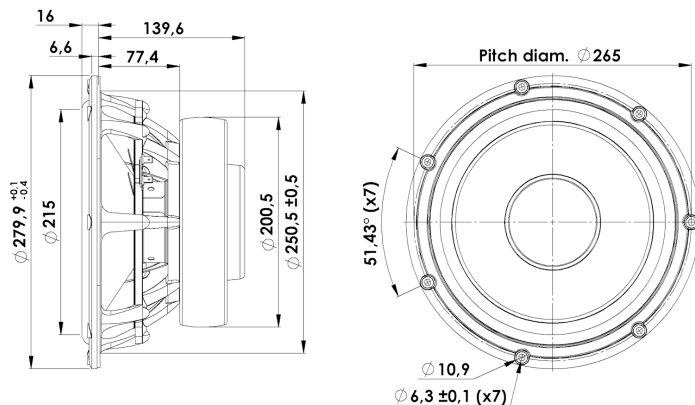

T-S Parameters:

Resonance frequency [fs]	18 Hz
Mechanical Q factor [Qms]	5.6
Electrical Q factor [Qes]	0.32
Total Q factor [Qts]	0.3
Force factor [Bl]	11.2 Tm
Mechanical resistance [Rms]	2.3 kg/s
Moving mass [Mms]	114.5 g
Compliance [Cms]	0.68 mm/N
Effective diaph. diameter [D]	215 mm
Effective piston area [Sd]	363 cm ²
Equivalent volume [Vas]	127 l
Sensitivity (2,83V/1m)	88 dB

Mechanical Data:

Voice coil diameter	75 mm
Voice coil height	36 mm
Voice coil layers	2
Gap height	8 mm
Linear excursion	± 14 mm
Max mech. excursion	± 26 mm
Unit weight	7.5 kg
Cabinet Displacement Volume	2.23 l

Electrical Data:

Nominal impedance [Zn]	4 Ω
Minimum impedance [Zmin]	3.8 Ω
Maximum impedance [Zo]	53 Ω
DC resistance [Re]	3.1 Ω
Voice coil inductance [Le]	0.5 mH

Power Handling:

100h RMS noise test (IEC 18.4)	200 W
Long-term max power (IEC 18.2)	500 W
X-over: 2. order LP Butterworth, 200 Hz	

Key Features:

- Paper sandwich cone
- Patented Symmetrical Drive motor
- Spider with balanced tinsel leads
- Extreme linear excursion (+/-14 mm)
- 3" Voice coil, Titanium former and paper reinforced
- Stiff and strong die cast aluminium chassis

Recommendations (please see Tech Note):

- Operating frequency range: fs-1000 Hz
- Cabinet volume - closed box: Vbox=35 ltr, f(-3dB)=39 Hz
- Cabinet volume - vented box: Vbox=65 ltr, fb=23 Hz, f(-3dB)=24 Hz

