

CODICE/CODE: **ZLS120150**

Batteria sigillata AGM DEEP-CYCLE (uso ciclico) al silicone
Silicon DEEP-CYCLE AGM maintenance free battery



| | | |
|--|---------------------------|---|
| Volt | | 12V |
| Capacity/capacità 25°C | 20h | 45Ah |
| | 5h | 35Ah |
| | 2h | 32Ah |
| Internal Resistance | Full Charged Battery 25°C | ≤7.1m Ω |
| Capacity affected by Temperature/Effetti della temperature sulla capacità | 40°C | 102% |
| | 25°C | 100% |
| | 0°C | 85% |
| | -10°C | 75% |
| Self-Discharge 25°C Capacity / Autoscarica a 25°C | after 3 month storage | 90% |
| | after 6 month storage | 80% |
| | after 12 month storage | 62% |
| Charge cycle/ Ciclo di carica | IU + h | "In" max. 9Amp; "V1" 2.43V/cell |
| | IUIa | "In" max. 9Amp; "V1" 14.4Volt; "If" 0.5Amp. |

| | | |
|--|----------|--------|
| Battery Dimensions/ Dimensioni batteria | L/L | 197mm |
| | W/P | 165mm |
| | H/A | 170mm |
| | Tot- H/A | 170mm |
| Weight/peso | | 14.3Kg |
| Terminal/terminal | | M6 |
| Plt. Qt. / Qt. per pallet | | 60 |
| Case/contenitore | | ABS |
| | | |
| | | |

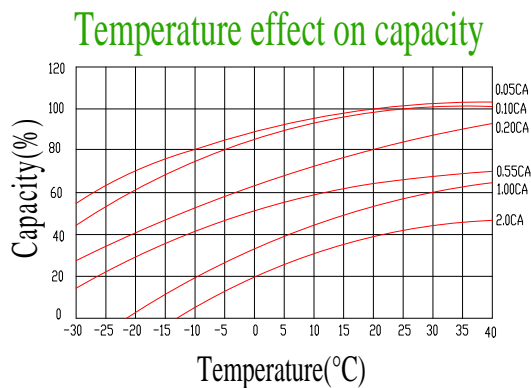
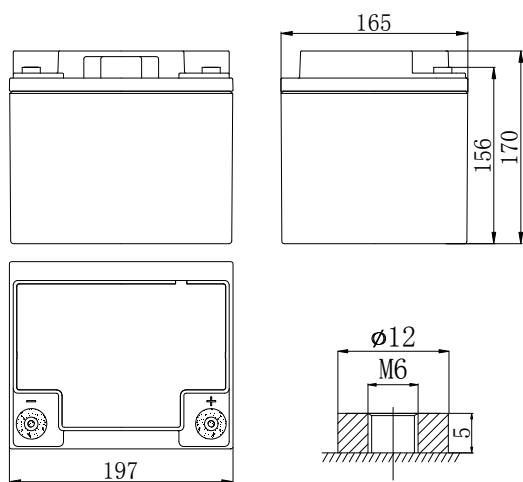

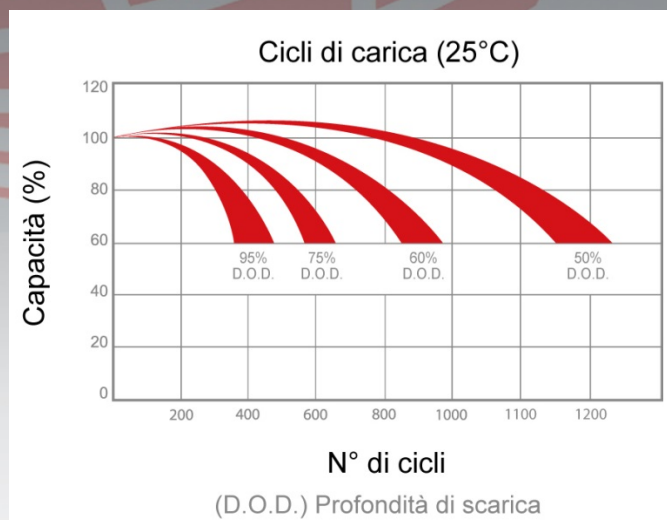

Charge cycle for sealed batteries (GEL/AGM): IU + holding

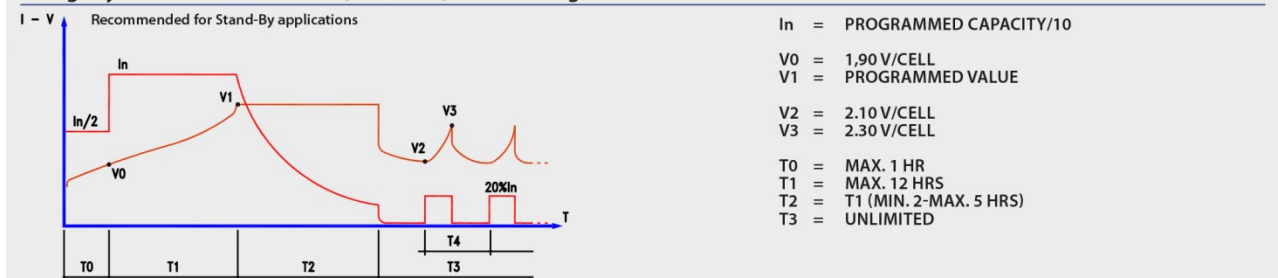

“IU1a” charge cycle is always recommended in case of more than 2 batteries in series
Ciclo di carica “IU1a” è sempre necessario qualora ci siano più di 2 batterie collegate in serie

