

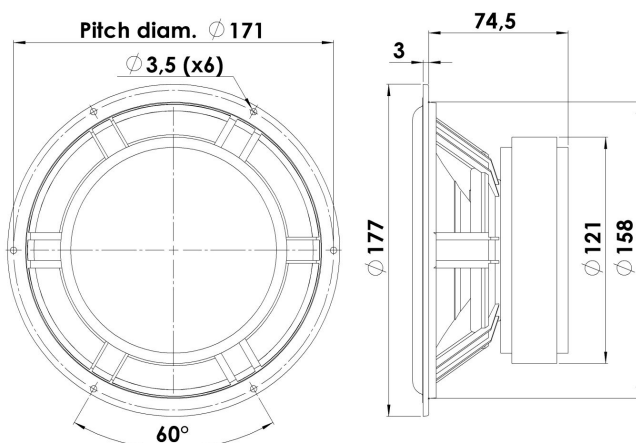

MIDWOOFER

18W/8542-00

The Symmetric Drive (SD) concept with copper in the magnet system was invented by Scan-Speak. High-quality magnet system design has thus been a key feature of Scan-Speak design since the companys inception. The Classic woofers are highly praised, and are used in some of the worlds most exceptional high-end Loudspeakers. Some feature Kevlar cones, others have the innovative Carbon fibre paper cones.



KEY FEATURES:

- Patented Symmetrical Drive Motor Design
- Air Dried Paper/Nylon Fibre Cone
- 42mm Voice Coil
- Low-Loss linear suspension
- Low Damping Coated Foam Surround

T-S Parameters

Resonance frequency [fs]	30 Hz
Mechanical Q factor [Qms]	1.70
Electrical Q factor [Qes]	0.26
Total Q factor [Qts]	0.23
Force factor [Bl]	7.8 Tm
Mechanical resistance [Rms]	1.66 kg/s
Moving mass [Mms]	15 g
Compliance [Cms]	1.88 mm/N
Effective diaph. diameter [D]	131 mm
Effective piston area [Sd]	135 cm ²
Equivalent volume [Vas]	47.9 l
Sensitivity (2.83V/1m)	89 dB
Ratio Bl/√Re	3.33 N/√W
Ratio fs/Qts	133 Hz

Notes:

IEC specs. refer to IEC 60268-5 third edition.
All Scan-Speak products are RoHS compliant.
Data are subject to change without notice.
Datasheet updated: February 18, 2015.

Electrical Data

Nominal impedance [Zn]	8 Ω
Minimum impedance [Zmin]	6.6 Ω
Maximum impedance [Zo]	41.5 Ω
DC resistance [Re]	5.5 Ω
Voice coil inductance [Le]	0.2 mH

Power Handling

100h RMS noise test (IEC 17.1)	70 W
Long-term max power (IEC 17.3)	130 W

Voice Coil & Magnet Data

Voice coil diameter	42 mm
Voice coil height	19 mm
Voice coil layers	2
Height of gap	6 mm
Linear excursion	± 6.5 mm
Max mech. excursion	± 10 mm
Unit weight	2.1 kg



MIDWOOFER

18W/8542-00

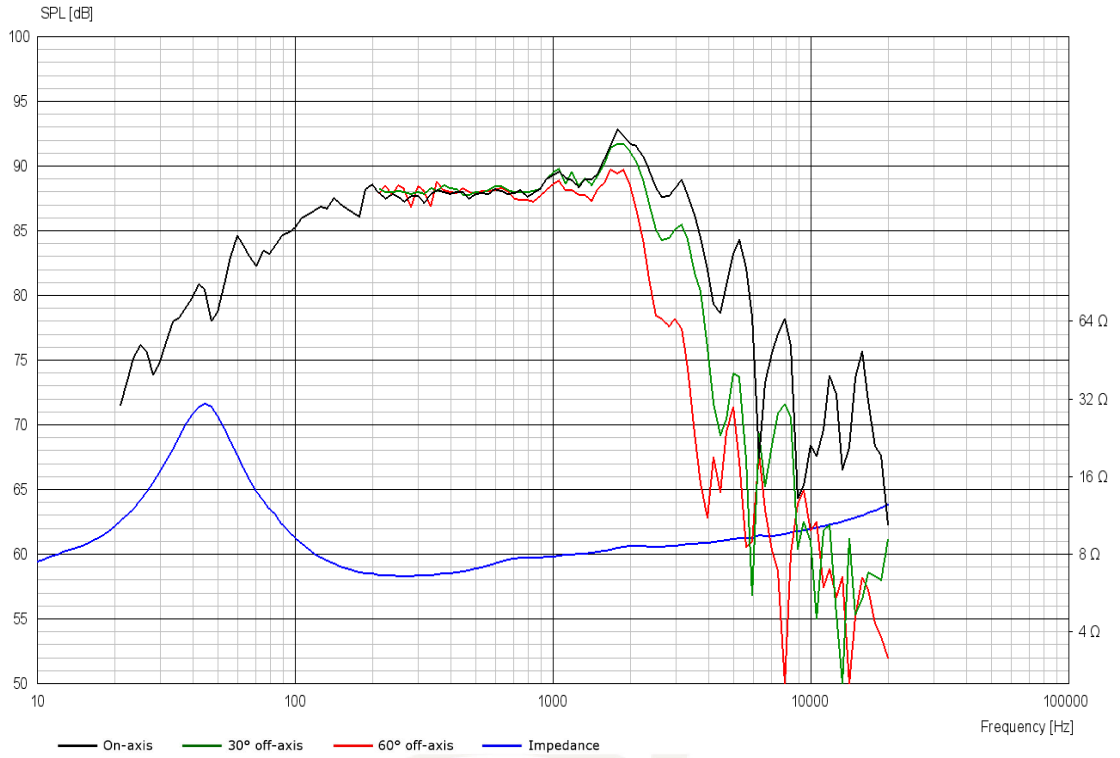

Advanced Parameters (Preliminary)

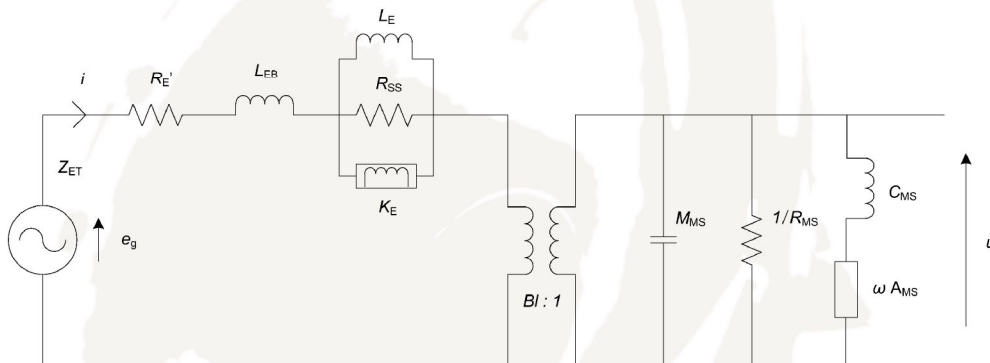

Electrical data

Resistance [$R_{E'}$]	5.69 Ω
Free inductance [L_{EB}]	0.059 mH
Bound inductance [L_E]	1.44 mH
Semi-inductance [K_E]	0.091 SH
Shunt resistance [R_{SS}]	5.00 Ω

Mechanical Data

Force Factor [BI]	7.28 Tm
Moving mass [M_{MS}]	15.6 g
Compliance [C_{MS}]	1.43 mm/N
Mechanical resistance [R_{MS}]	1.90 kg/s
Admittance [A_{MS}]	0.26 mm/N