

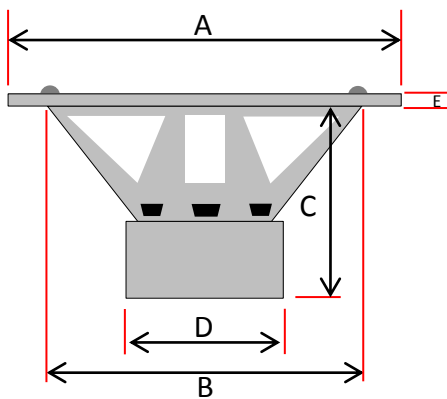

TECHNICAL SPECIFICATIONS

Product name	GZIW 165X	Gasket	PVC
Product type	Subwoofer chassis	Terminal	Chrome push terminal
Diameter	168 mm / 6.6"	Power handling	100 W RMS
Mounting diameter	147 mm / 5.79"	Impedance	4 Ohm
Mounting depth	80 mm / 3.15"	Re	3.3 Ohm
Magnet dimension	110 x 20 mm	Res	19.9 Ohm
Total weight	1.9 KG	FS	43 Hz
Voice coil diameter	38 mm / 1.5" Round Wire	Qms	6.02
Voice coil winding height	17 mm / 0.669"	Qes	0.38
Voice coil wire material	Copper	Qts	0.36
Voice coil former material	Kapton	Rms	1.3 kg/s
Top plate height	5 mm / 0.2"	Cms	0.49 mm/N
Linear excursion (one direction)	6 mm / 0.24"	Mms	28 gr
Effective Xmax	12 mm / 0.47"	BL	8.1 N/A
Top Plate and T-Yoke color	Black	SPL (1w/1m)	85.5 dB
Basket material	Steel	VAS	11 L / 0.388 cu.ft
Basket color	Black	Le	1.35 mH
Spider	Polycot	Recommended freq. response	40 – 200 Hz
Surround	Rubber	Recommended amplifier power	60 – 150 WRMS @4 Ohm
Cone	IMPP	Sound Quality	☺
Dustcap	IMPP konvex / with 3D Logo	SPL Competition	☺
Magnetcover	PVC	Low bass performance 20-50Hz	☺
		Mid bass performance 50-80Hz	☺



A	168 mm / 6.6" (170 mm / 6.69")
B	147 mm / 5.79"
C	80 mm / 3.15 "
D	110 mm / 4.33"
E	4 mm / 0.16" (11 mm / 0.43")

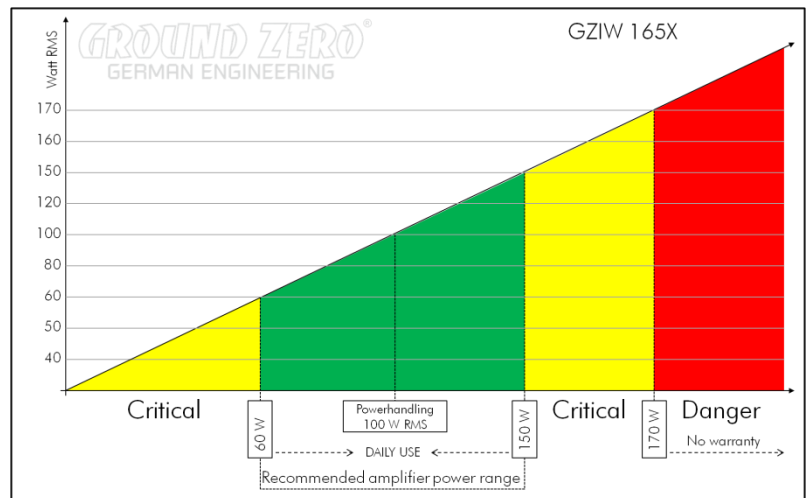

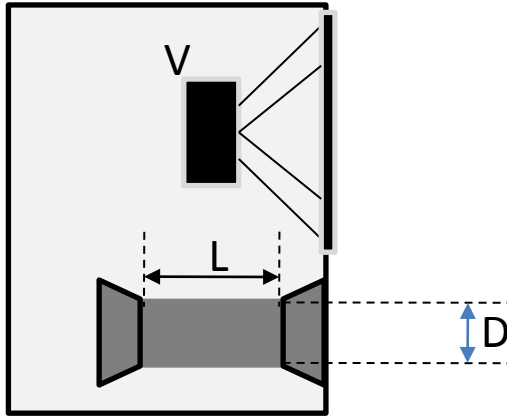
BOX RECOMMENDATION

Small size vented box

V: 11 L / 0.388 cu.ft

D: 1x 50 mm / 2"

L: *220 mm / 8.66"

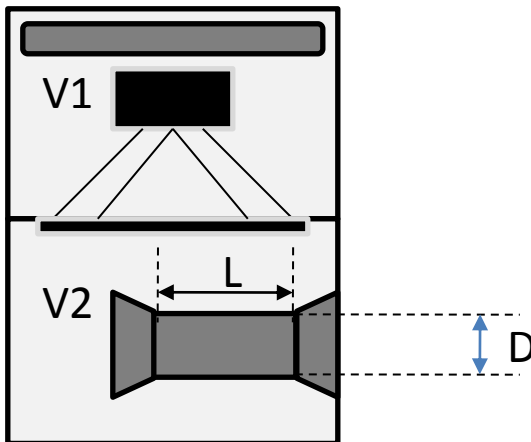
No damping

Small size bandpassbox

V1: 6 L / 0.21 cu.ft

V2: 6 L / 0.21 cu.ft

D: 1x 50 mm / 2"

L: *230 mm / 9"

20% polyester wool in V1

No damping in V2

Die hier aufgeführten Gehäusevorschläge sind nur einige, der möglichen Varianten.

Bitte beachten Sie zudem, dass die finale Abstimmung, speziell die Port Längen je nach Fahrzeug und eigenem Geschmack variiert werden sollte.

Above-mentioned enclosure recommendations are just a few possible variations.

Please note that you should find the perfect tuning, especially port length, based on your car and own taste.



BOX RECOMMENDATION

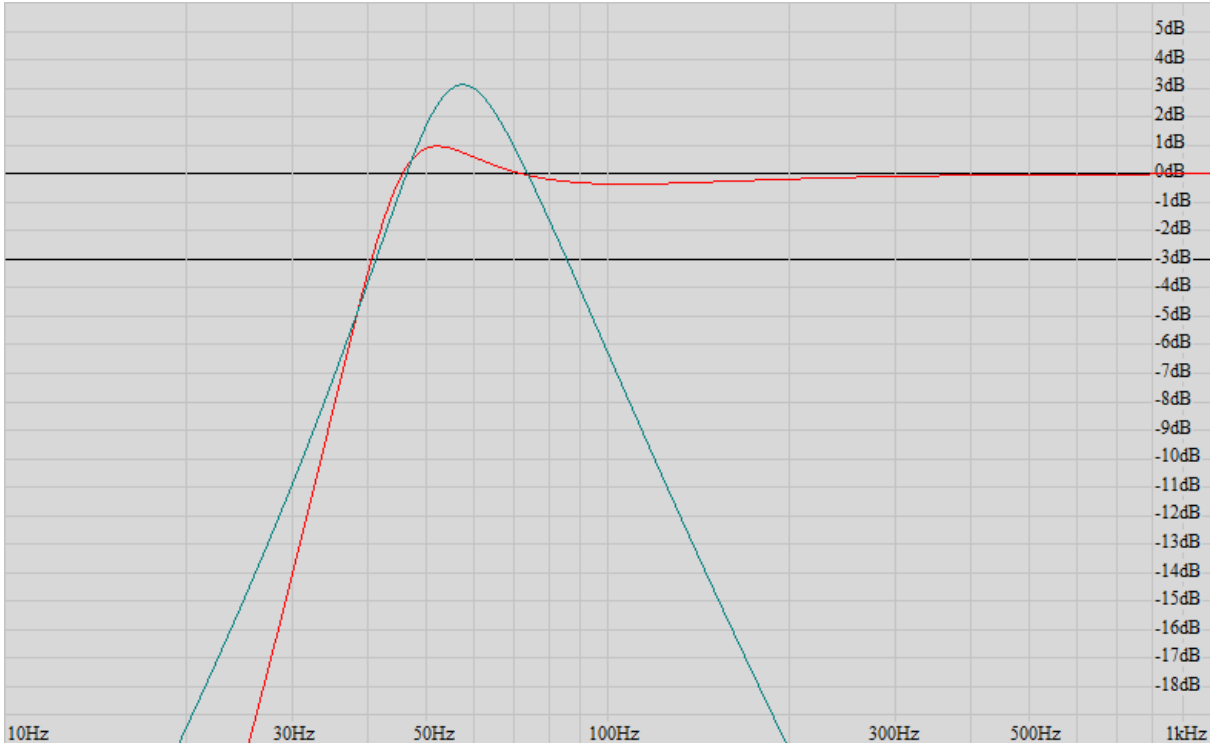

Curve	Type	Volume	F3/ Qtc
Red	Vented	11 L / 0.388 cu.ft	40 Hz
Green	Bandpass 4th order	V1: 6 L / 0.21 cu.ft V2: 6 L / 0.21 cu.ft	Centerfreq. 60 Hz

Die hier aufgeführten Gehäusevorschläge sind nur einige, der möglichen Varianten.
 Bitte beachten Sie zudem, dass die finale Abstimmung, speziell die Port Längen je nach Fahrzeug und eigenem Geschmack variiert werden sollte.
Above-mentioned enclosure recommendations are just a few possible variations.
Please note that you should find the perfect tuning, especially port length, based on your car and own taste.

