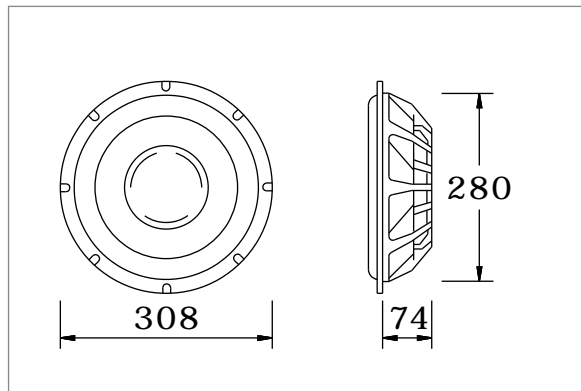

XP 12 - 308 mm passive radiator**TECHNICAL DATA**

<u>resonance frequency (Fs)</u>	10 Hz
<u>mechanical Q factor (Qms)</u>	15.2
<u>equivalent volume (Vas)</u>	170 litres
<u>compliance (Cms)</u>	0.55 mm/N
<u>moving mass (Mms)</u>	425 g
<u>emission diameter (D)</u>	244 mm
<u>linear excursion (Xmax)</u>	± 24 mm

<u>cone material</u>	composite cellulose
<u>surround material</u>	SBR rubber
<u>basket material</u>	aluminium die cast