

SB 260 - bass reflex subwoofer

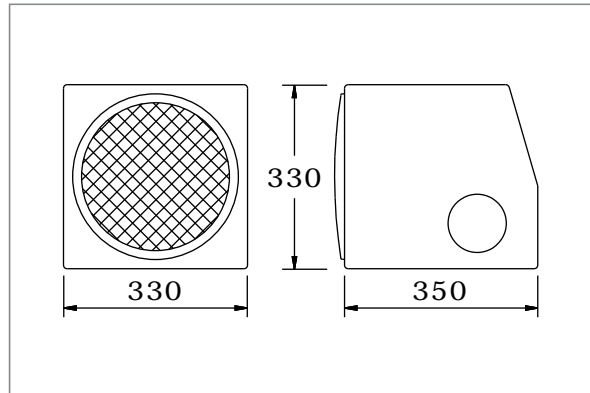

TECHNICAL DATA

<u>nominal impedance (Zn)</u>	4 ohm
<u>nominal power (Pn)</u>	150 watt
<u>max power (Pm)</u>	300 watt
<u>sensitivity (2.83 V/1 m)</u>	92 dB
<u>frequency range (BW)</u>	35 ÷ 200 Hz
<u>internal volume</u>	23 litres

loudspeaker data:

<u>nominal impedance (Zn)</u>	4 ohm
<u>nominal power (Pn)</u>	150 watt
<u>max power (Pm)</u>	300 watt
<u>speaker diameter</u>	266 mm
<u>voice coil diameter</u>	50 mm
<u>cone material</u>	cellulose
<u>surround material</u>	butyl rubber
<u>basket material</u>	stamped steel
<u>magnet material</u>	ferrite

<u>suggested filter</u>	NTS 12
-------------------------	--------

FEATURES

Schema di collegamento ad amplificatori senza uscita filtrata per subwoofer.

Linking scheme to amplifiers without subwoofer filtered output.

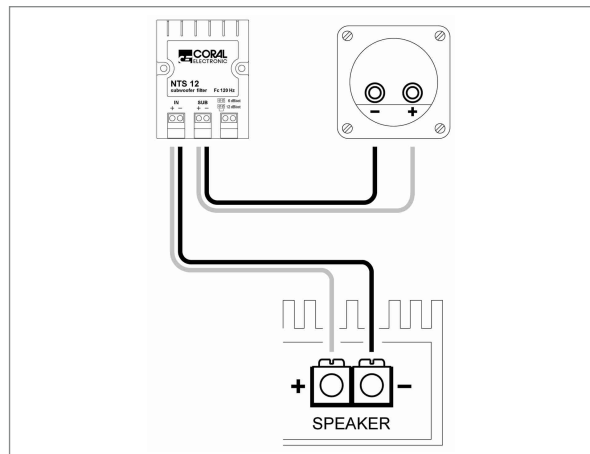

Schema di collegamento ad amplificatori con uscita filtrata per subwoofer.

Linking scheme to amplifiers with subwoofer filtered output.

