

HE 165 PWR - 165 mm woofer

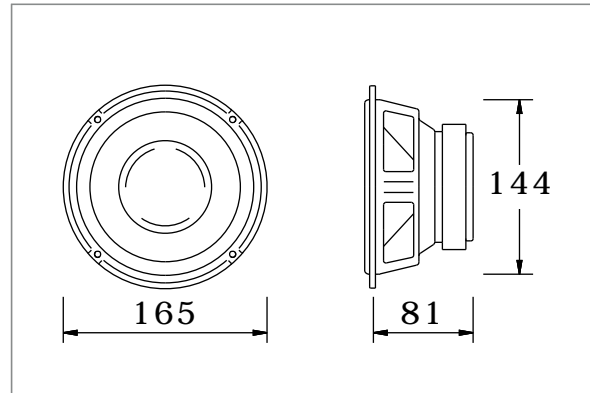

TECHNICAL DATA

nominal impedance (Z_n)	4 ohm	mechanical Q factor (Q_{ms})	2.52
nominal power (P_n)	150 watt	electrical Q factor (Q_{es})	0.72
max power (P_m)	300 watt	total Q factor (Q_{ts})	0.56
sensitivity (2.83 V/1 m)	90 dB	moving mass (M_{ms})	21.6 g
frequency range (BW)	60 ÷ 4000 Hz	compliance (C_{ms})	0.3 mm/N
resonance frequency (F_s)	62 Hz	equivalent volume (V_{as})	8.6 litres
voice coil diameter	33 mm	force factor ($B \times L$)	6.5 N/A
cone material	composite CSC	voice coil resistance (R_e)	3.6 ohm
surround material	butyl rubber	voice coil inductance (L_e)	0.7 mH
basket material	stamped steel	emission diameter (D)	135 mm
magnet material	ferrite	linear excursion (X_{max})	± 5 mm

FEATURES

Combinando le caratteristiche di due strati di polipropilene con carichi differenziati ad uno strato intermedio smorzante, abbiamo raggiunto un livello di prestazioni del cono assolutamente senza precedenti, per risposta ai transitori, trasparenza e neutralità timbrica.

L'anello di cortocircuito in alluminio (aluring), riducendo le non linearità tipiche dei circuiti magnetici tradizionali, incrementa la capacità di controllo dell'escursione della bobina mobile, con il conseguente abbattimento della distorsione alle frequenze medio-basse ed il sensibile incremento della capacità dinamica.

By combining the characteristics of two differently filled polypropylene layers with a highly damped coupling layer, we obtained a cone performance which is absolutely outstanding, for transient response, transparency and tonal balance.

The aluminium short circuit ring (aluring), by reducing the non-linearity which affects all the commonly made magnet systems, increases the excursion capability control of voice coil, giving a strong reduction of low and mid frequency harmonic distortion and a much wider dynamic headroom.

