



ST-D BT SERIES
Owner's Manual

Before operating the unit, please read this manual throughly and retain it for future reference.

Contents

Item	Page
Mission Statement	1
The Zapco Studio Series	2
Warnings (avoid future problems)	3
Install Sense	4
Making Power	4
Basic Installation Guidelines	5
Gain Setting	5
Safe Sound	6
Studio-D BT SERIES	7
ST-64D BT	7
ST-104D BT	8
ST-105D BT	11
ST-204D BT	13
ST-402D BT	15
System Diagrams	18
Channel Systems	21
Studio Amp Specifications	22

Mission Statement

Committed to excellence

ZAPCO is dedicated to the pursuit of audio fidelity. Our prime objectives are to design and manufacture audio products of unsurpassed quality, to provide unparalleled support and service for these products, and to conduct business in a manner that will enhance the quality of life for all involved.

Experience

Knowledge from doing

There is absolutely no substitute for experience; that is a simple fact of life. Another simple fact is that ZAPCO has, for over thirty years, been the leader in defining quality standards for the car audio industry. These years of experience have led to a thorough understanding of the challenges that are unique to the world of car audio. ZAPCO's relentless quest for sonic purity consistently yields imaginative designs that utilize the most innovative technologies. The resulting products set the criteria by which all others in the industry are judged.

Zapco Studio Series Amplifiers

With the studio Series of amplifiers Zapco brings the sound quality and reliability that built the Zapco legend to an amplifier line that everyone can afford.

Zapco has a reputation for sound reproduction and quality that is unsurpassed. It is our dedication to sonic purity and our passion for performance that built that reputation. With all the new amps coming into the market, not one has been any threat to Zapco's standing as the premium amp and processor line. Just check the audio competition scene and the audio forums. The pros know what to use to win.

But not everyone wants to compete. The question was this. Could Zapco put it's 40-years of audio experience to work to develop an amp for everyday use? An amp that all can afford but that will stay true to the Zapco heritage for sound and reliability?.

Absolutely! We can and we have! The Studio amplifiers are a testament to the fact that you can build a quality product with great sound in an amplifier for everyday use.

Now, the Studio-D BT amps take the Studio line to a whole new level of power and compactness with new full range Class D applications using a revolutionary new NXP control technology for the "micro" chassis amps and a new TI technology for the compact chassis amps. All to assure that the Studio amps will hold true to Zapco's standards for sound quality and reliability.

While sound quality and reliability are always the top priorities in a Zapco design, there are other factors in the Studio-D BT design that make them great "every-day"amps. The extruded aluminum chassis is more compact to make the ST-D BT amps an easier fit in today's smaller cars. Some are only 95mm (3³/₄") wide. And the new Class D technologies have no more radio interference than the best Class A/B amps, so ball games, traffic reports and all your other commuting listening needs will come in crystal clear.

The feature set of the Studio amps provides you with all the system versatility you need without adding additional components, with everything from crossovers to preamp outputs, so multiple amps don't require extra signal cables. In addition, the Studio DBT amps give you **Bluetooth Music Streaming** so you can automatically pair up your iPod or other smart device and stream music directly to your amplifier. *The Preamp outputs of the ST-D BT amps will even take your streamed music out to the next amp in your system*

How about power? The Studio-D BT full range Class D amps have tons of power. The mini chassis ST-64DBT gives you *340 watts RMS* in an amp that you can literally carry in your back pocket. The compact chassis ST-D BT amps are only about 160mm x 300mm (6.5" x 11.5"), and they each put out over 1,000 watts RMS.

If you want to add a bass amp, the Studio-XM Class D bass amps let you choose any power from 500 Watts to 2,000 watts. And since they can be strapped together, you can have up to about 4,000 watts for that monster subwoofer

Power, price, size, and performance. This is an amp designed to knock your socks off ... in your car, for your daily use, every day.

So go ahead...Pop in your favorite disk, grab the volume, and see if you don't agree. Dedication to sonic purity and big *real* power is definitely a good thing.

What's next? Only time will tell. But here's one thing you can count on. As ZAPCO finds new ways to improve the state of the art, we will bring them to you immediately, in all our products.

So! Enjoy this manual. We hope you will read it thoroughly. We have tried to include all the necessary information for proper installation and set up of your Zapco Studio-DBT amplifier.

Warnings

ZAPCO highly recommends that a fuse or circuit breaker be placed within 18" of the vehicle's battery. Although products have adequate internal protection, it is possible that a pinched power wire between the component and the battery may result in a fire if the wire is not protected. The protection device should be placed where it can be accessed easily and all wiring should be routed safely and correctly according to the following guidelines:

- Do not run wiring close to hot or spinning objects.
- Always use wire grommets when routing wire through the firewall or any other metal panels.
- Make sure that the potential for pinched wiring is avoided by routing all wires away from moving hinges and seats. This also includes brake, gas and clutch pedals, hood and trunk hinges, etc.
- And Absolutely...Use the correct gauge wire for you amplifiers current demands

Install Sense

As a manufacturer, Zapco has taken great pains to produce a product that will give you many years of superior performance and reliability. However, certain basic rules need to be followed if you want to achieve the product's full potential in your vehicle

It Takes Power to Make Power

The gauge of the power and ground wire is critical to your system. If the wire gauge is too small your amp will never produce its rated power. Even worse... Straining to produce power from insufficient current can over-tax the power supply of your amp and cause amp failure.

See the chart below:

Recommended Wire Gauge

Up to	4Ft	7Ft	10Ft	13Ft	16Ft	19Ft	22Ft	28Ft
20 A	14	12	12	10	10	8	8	8
35 A	12	10	8	8	4	4	4	4
50 A	10	8	8	4	4	4	4	4
60 A	8	8	4	4	4	4	4	2
85 A	4	4	4	4	2	2	2	0
105 A	4	4	4	2	2	2	2	0
125 A	4	4	4	2	2	0	0	0
150 A	2	2	2	2	0	0	0	0

Be Safe:

- Add up the fuse recommendations of all the amps in your system.
- Then see how long a run you will have from the battery to the amplifiers .
- Now locate the wire gauge on the chart above.

i.e. If your amps need a total of 125 amps and your wire run will be 16ft long you will need to use at least a 2 gauge wire. Anything less and your car won't go boom. It'll just go Blaap! **And you can damage your new amplifier.**

Ground Matters just as much as power. Electricity travels in a circuit. The ground wire needs to be the same size as the power wire or current (and power) will be reduced. A weak ground connection will also limit current flow.

You need a good solid ground connection to the vehicle frame. Remember: A body panel is not a frame. Many metal body panels never even make contact with the frame. Make sure you have a solid ground to the frame, to guaranty you will get full performance from your system.

Fusing: In addition to the fuses at the amplifiers, always fuse the main power lead at the battery to protect the vehicle in case of amp or wiring failure. Contact an installation professional for further advice.

Basic Installation Guidelines

Mounting your Studio Series Amplifier is relatively easy. Just keep in mind the following guidelines:

- The amplifier may be mounted in any direction, on wood, metal or carpet.
- The metal case of the amplifier may be grounded or left isolated.
- The amplifier requires adequate ventilation. Position the amplifier with sufficient surrounding area for proper cooling.
- Keep any fan and vent end plates clear for proper internal cooling.
- Keep the amplifier out of the engine compartment and other locations
- Do not mount the amplifier to a subwoofer enclosure or any other place that may have excessive vibration!

Setting Gains (Input sensitivity)

Proper gain setting is one of the most important factors in setting up a stereo system. At the same time, gain setting is quite often done wrong. Turning up the gain of an amp is the very last thing you should ever do to in setting up a system.

An amplifier is a step up transformer. Period. Any signal you put in is boosted by a fixed factor. Music, hiss, or any other noise, it doesn't matter. A large number of noise problems are simply a matter of improper gain settings.

The goal of gain setting is to achieve the maximum amount of musical output from the amplifier while getting the least amount of hiss or noise from the system. Your Studio Series amplifier accepts an extremely wide range of input levels. As little as .25 volts to as much as 8 volts at the RCA inputs. The basic gain setting is very simple and requires no special tools. Whether you have a simple system with a deck and an amp, or a system with a deck, line driver, equalizer, crossover, and amp, The procedure is always the same.

- First, hook up the system with all gain controls at minimum (turn the gain pots fully counter-clockwise with a small screwdriver).
- Then turn on the head unit and turn up the volume. If you achieve clean sound, and more volume than you want, you don't need to make any adjustments. However, if you turn up the volume and begin to hear distorted sound before it becomes loud, you are clipping (distorting) the deck (probably a little over $\frac{3}{4}$ volume).
- Turn the deck down just enough to hear clean sound again, and then move to the next component in your system. With the deck playing at "maximum clean volume" adjust the gain of the next component to its "maximum clean volume".

If you adjust your gains this way, always starting at the head unit and working down the line to the amplifier, you will get the most performance out of your amplifier(s) with the least amount of unwanted distortion and noise.

Safe Sound

A quick word about very serious safety issue:

Continuous exposure to excessive sound pressure levels may cause permanent hearing loss. It is not unusual for customers new to high-end sound quality to complain that their Zapco amps sound wonderful, but "they just don't get loud".

NOTE: A clean undistorted system simply will not sound loud. Distortion is what makes a system "sound loud", not sound pressure.

Here's the problem: Having properly set gains will allow you to comfortably play your Zapco system at a much higher SPL without sounding "loud". However, the fact that it is now more comfortable to play at a higher SPL does not mean it is safer. The functioning devices in your ear do not have very good pain receptors. So even if it does not "feel" like it hurts, excessively high SPL absolutely will damage your hearing.

So, please practice safe sound!

Install Note For High level OEM Hook-up:

Speaker level input plugs: The 2 channel and 4 channel Studio Amplifiers have speaker level inputs. There are 5 connections for speaker level inputs on some models. The fifth wire is "Signal Ground". For best performance and lowest noise this wire should be grounded at the chassis of the factory head unit. Invest a little time now and you will get better performance for years.

The Studio-D BT Micro Chassis Amplifiers

The Studio-DBT amps are full range class D with the latest generation of NXP Class D control. What this means to you is great sound like Class A/B, but with crazy-high efficiency (over 90%). This means less current draw, less heat, and smaller chassis. Another advantage to the new Class D control is that these new full range Class D amps have no more EMI (cause of radio interference) than Class A/B amps. So, if you want to turn the radio on for background music, or if you want to hear a ball game, you can do that and get crystal clear tuner reception with even the high power of Studio-D BT models.

ST-64DBT

There are two "micro" chassis models of ST-D BT amps. While the features and hook-ups are identical they vary slightly in physical size and more so in power. The 4-Channel ST-64DBT is the smallest of all the ST-D BT amps at 95mm (3.5)" x 213mm (8.4") but with 340 watts RMS it provides plenty of power for Co-Ax's or separates front and rear, or for separates up front and 10" sub-woofer wired mono on the rear channels

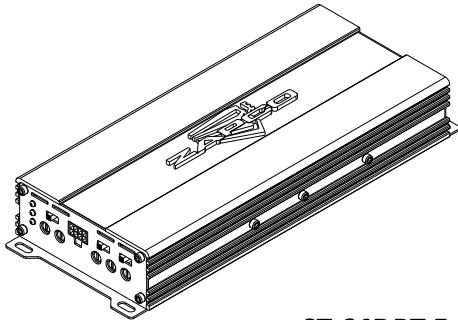

- 4-Channel
- Micro Chassis
- Class D Full Range
- 340 Watts RMS
- 90 watts RMS/Ch @ 2Ω
- Bluetooth Music Streaming

ST-64DBT Features

- Variable LP/HP/Full Electronic Crossover
- Variable bass boost
- RCA pass through outputs
- Hi level inputs
- Switchable Auto-on function

See the End Panel controls and connections Pp 8/9

NOTE: Just because these are "micro" chassis amps, doesn't mean you can skimp on the wire. Even at over 90% efficiency, it takes current to make power. Check out the chard on Pp 4. If you want to get the full potential from these micro amps you'll need to run at least 4Ga main power and ground wire for the ST-64D BT in most cars and 2Ga for the ST-104D BT

ST-104D BT

The ST-104D BT gives the Micro chassis a serious bump in power, up to 520 watts RMS power, with 130W/Ch at 2 ohms. It does this in the same 3½ inches of width and only adds a little over an inch in length (29mm)

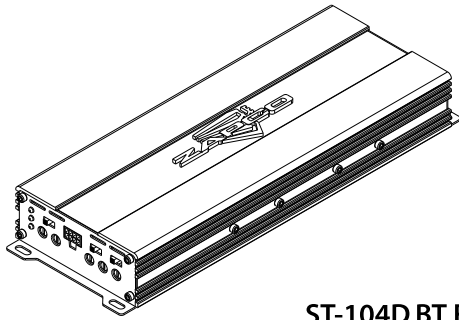

- 4-Channel
- Micro Chassis
- Class D Full Range
- 520 Watts RMS
- 130 watts RMS/Ch @ 2Ω
- Bluetooth Music Streaming

ST-104D BT Features

- Variable LP/HP/Full Electronic Crossover
- RCA pass through outputs
- Switchable Auto-on function
- Variable bass boost
- Hi level inputs

Micro Chassis Controls and Connections

Micro Chassis Control End

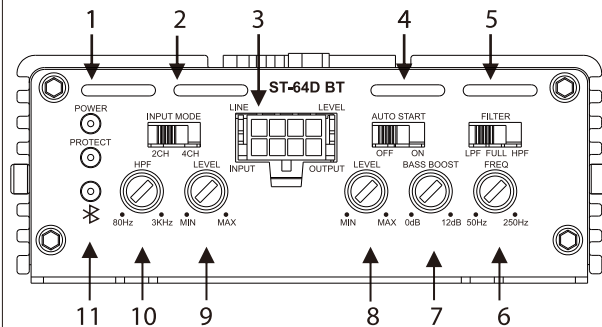

1. Power and Protect LEDs
2. Select front and rear inputs, or have both use the front input signal.
3. RCA Connector plug provides input Signal leads and the preamp output for another amp.
4. Auto-on Switch allows you to by-pass the auto-on circuit if your car is not compatible with automatic turn on
5. Crossover selector picks high pass, low pass, or full range for the rear outputs
6. Control determines the crossover frequency for the rear outputs
7. Bass Boost allows 6dB to 12dB of boost of for the bass frequencies
8. Rear channels input gain control
9. Front Channels input gain control
10. High pass frequency control for the Front outputs
11. Bluetooth status indicator lets you know when the Bluetooth is active

Wiring Connections

Micro Chassis! 95mm (3½") of end plate area does not leave you much room for terminal blocks or RCA plugs, so the ST-64D BT and ST-104D BT amplifiers uses molex connectors at the end plates to conserve space without giving up the features that you want in your car sound system. Speaker in/out harness is color coded using the standard autosound wire colors for right, left, front, and rear

The Micro Chassis Power End

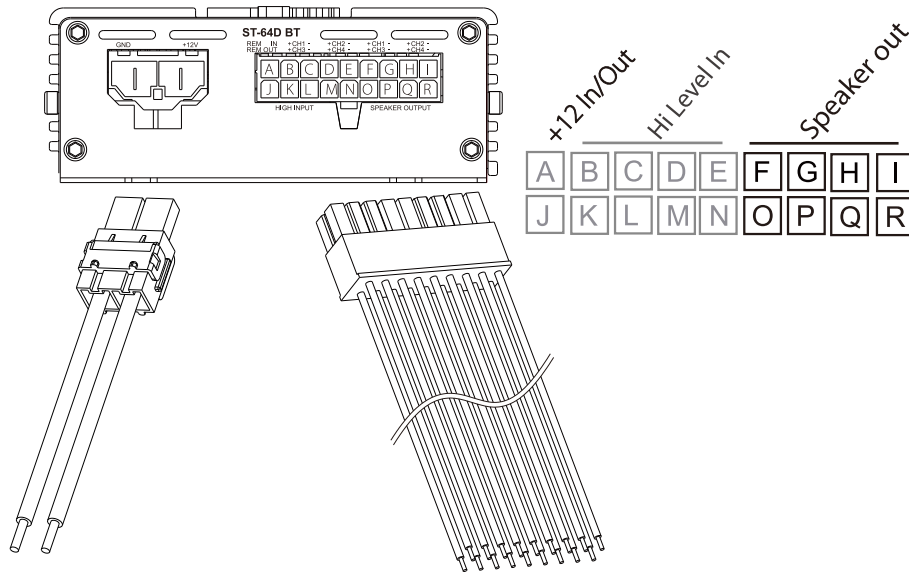

Top Row

- Blue **A** +12V Turn on
- White **B** Left Front Hi In +
- White/Black **C** Left Front Hi In -
- Gray **D** Right Front Hi In +
- Gray/Black **E** Right Front Hi In -
- White **F** Left Front Spk +
- White/Black **G** Left Front Spk -
- Gray **H** Right Front Spk +
- Gray/Black **I** Right Front Spk -

Bottom Row

- Yellow **J** +12V T rigger Out
- Green **K** Left Rear Hi In +
- Green/Black **L** Left Rear Hi In -
- Violet **M** Right Rear Hi In +
- Violet/Black **N** Right Rear Hi In -
- Green **O** Left Rear Spk +
- Green/black **P** Left Rear Spk -
- Violet **Q** Right Rear Spk +
- Violet/Black **R** Right Rear Spk -

Micro Chassis Amp Signal Leads

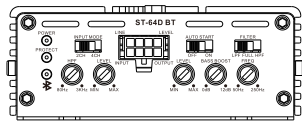

A	B	C
D	E	F

- A • Ch 1- Lft FrontF Input
- B • Ch 3- Lft Rear Input
- C • Left **Bluetooth** Output
- D • Ch 2- Rt Front Input
- E • Ch 4 - Rt Rear Input
- F • Right **Bluetooth** output

Note: Bluetooth Outputs function to send the Streamed Bluetooth signal to another amplifier

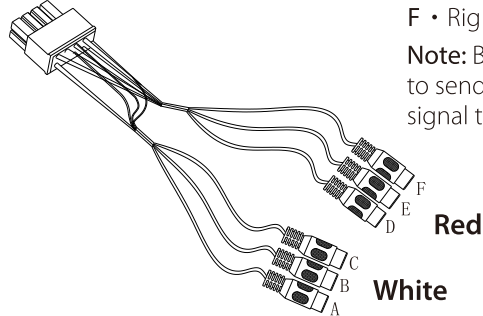

Fusing the Micro Chassis Amps

The Micro chassis Studio D BT amps do not have internal fuses and require an external fuse. Because of the extremely small chassis, the power and ground wires are in a 2 position Molex plug. They are both 10Ga wires. These wires should not be extended, but rather attached to an external fuse of 40Amps for the ST-64D BT and 60 amps for the ST104D BT.

Another fuse should be placed in the main power cable running from the battery to the back of the vehicle. This fuse should be close to the battery and should provide enough current to handle requirements of all the amps in the system..

The Studio-D BT

Compact Chassis Amplifiers

There are three compact chassis Studio-D BT amplifiers, the ST-105D BT, the ST-204D BT, and the ST-402D BT. A 5-Channel, a 4-Channel and a 2-Channel amp. These amps have similar technology to the micro chassis units, with over 90% efficiency, low EMI, and great Zapco sound. So Why are they bigger? **POWER!**

The Compact Chassis Studio-D BT amps each have over 1,000 watts RMS. That's crazy power in a chassis only 160mm x 300mm (about 6.5" x 11.5").

ST-105D BT

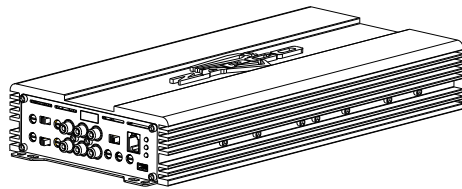

- 5 Channel
- Compact Chassis
- Class D Full Range
- 1,070 Watts RMS
- 180W x 4+350 x 1 @ 2 Ω
- Bluetooth Music Streaming

Features

- Variable Electronic Crossover
- Variable bass boost
- Internal Mono Bass amp
- 2ch, 4ch, 5ch input mode selection

ST-105D BT Controls and Connections

ST-105D BT Control End

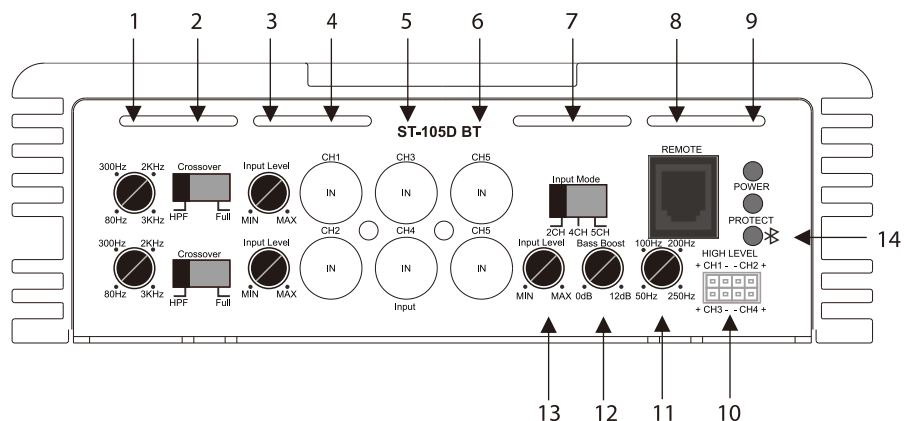

1. Frequency selector for the High Pass crossover on front channels (Top) and rear channels (Bottom)
2. Crossover selector turns on High Pass crossover for front channels (top) and rear channels (bottom)
3. Input gain control for front channels (Top) and rear channels (Bottom)
4. Front channel Input RCA connectors
5. Rear channel Input RCA connectors
6. Bass channel input RCA connectors (For best signal use both Ch5 inputs mono)
7. Mode switch allows you to choose to use all 3 pair of input connectors (if you have six head unit outputs) or use only Front and Rear inputs (if you have only a 4 channel head unit output) and still have bass on Channel 5, or to run all 6 channels from just a single 2 channel input.
8. Port for the Dash Remote
9. Power/ Protect LEDs show the operating status of the amp.
10. High level input plug for use with a factory head unit
11. Low Pass frequency selector for the bass crossover
12. Bass Boost switch adjusts bass boost from 0dB to 12dB of boost
13. Bass section input gain control
14. **Bluetooth** LED illuminates when the Bluetooth streaming is active

ST-105D BT Power end

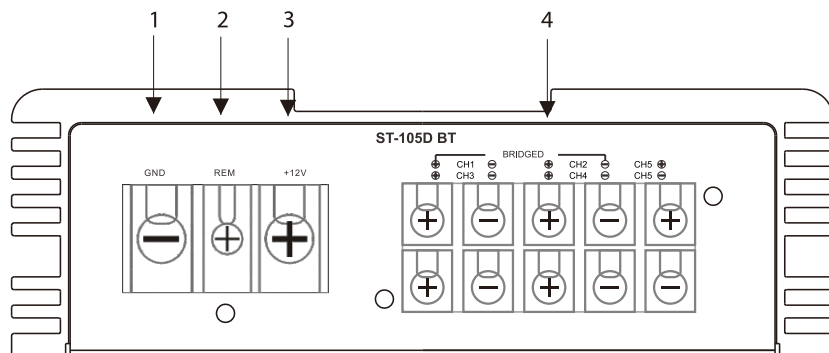

External fuse required. Recommended 90 Amps

1. GND The amp should have a firm connection the car frame. * See section "Install Sense"
2. REM The remote terminal connects to the head unit remote out, or to some other switched 12 volt source to turn on the amplifier.
3. +12V The main 12 volt must be connected directly to the vehicle's battery using wire of the proper gauge. * See section "Install Sense"
4. Speaker connections The heavy duty terminal block provides positive speaker connections. Simply insert the wire and cinch down the set screw. Note that the Mono bridge positions are L+ to R -, for both front and rear speaker sets

ST-204D BT

The ST-204D BT takes all the power of the 105D BT and pours it into 4 channels of 180 Watts RMS each @ 4 Ω and 280 Watts RMS @ 2 Ω . This is roughly the same size as the Class A/B 4 channel but over twice as much power ... And you get Bluetooth music streaming.

ST-204D BT

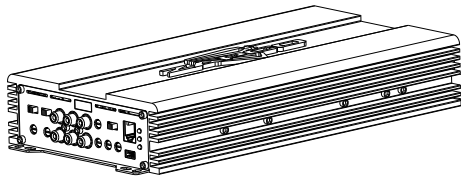

- 4 Channel
- Compact Chassis
- Class D Full Range
- 1,120 Watts RMS
- 280 Watts x 4 @ 2 Ω
- Bluetooth Music Streaming

Features

- Variable Electronic Crossover
- Variable bass boost
- Hi/Low/ or Band Pass Crossover
- 2ch/4ch input mode selector

The ST-204D BT Controls and connections

ST-204D BT Control end

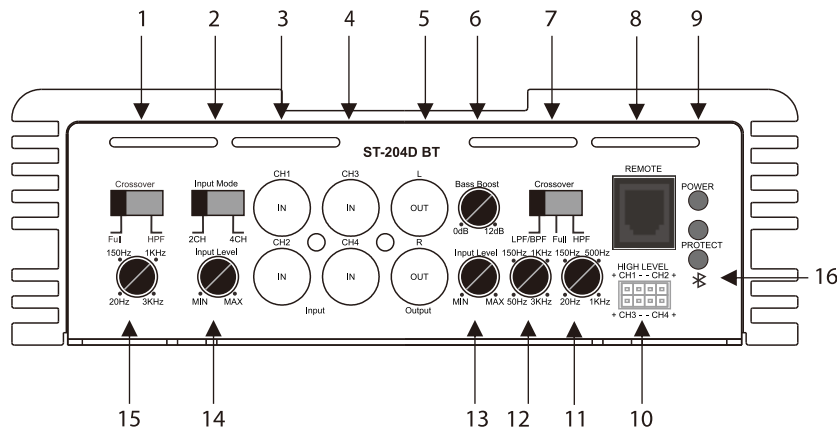

1. Crossover selector to turn high pass crossover on or off
2. Input mode switch to choose 4 channel inputs or have all channels from front in only
3. Front RCA input connectors
4. Rear RCA input connectors
5. Preamp/Bluetooth output to provide streamed signal to another amplifier
6. Rear channels Bass Boost can be set from 0dB to 12dB of boost
7. Rear crossover can be set for High Pass Low Pass or Band Pass
8. Port for Dash remote bass control
9. Power/Protect light shows operating status of the amp
10. High level input for OEM integration with a factory head unit
11. Rear High pass frequency control 20Hz to 1KHz
12. Rear Low pass frequency control 50Hz to 3KHz
13. Rear channels input gain control
14. Front channels input gain control
15. Front channels HP crossover frequency selector
16. Bluetooth streaming LED indicator

ST-204D BT Power end

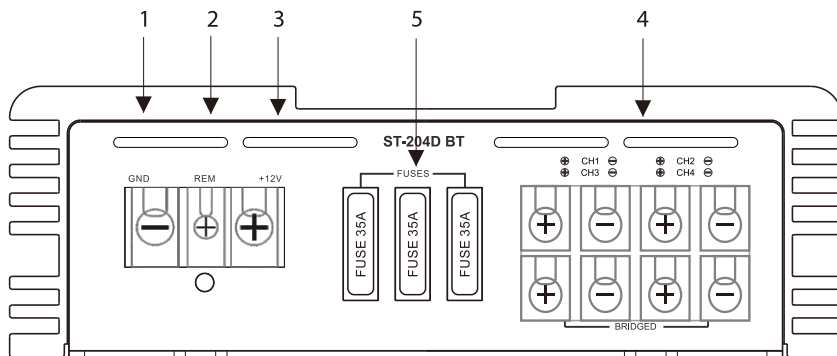

1. GND The amp should have a firm connection the car frame. * See section "Install Sense"
2. REM The remote terminal connects to the head unit remote out, or to some other switched 12 volt source to turn on the amplifier.
3. +12V The main 12 volt must be connected directly to the vehicle's battery using wire of the proper gauge. * See section "Install Sense"
4. Speaker connections The heavy duty terminal block provides positive speaker connections. Simply insert the wire and cinch down the set screw.
Note that the Mono bridge positions are L+ to R-, for both front and rear speaker sets
5. Fuses: If needed, always replace with the same size fuses

ST-402D BT

The ST-402D BT takes all the power of the 204D BT and pours it into 2 channels of 380 Watts RMS each @ 4 Ω and 550 Watts RMS each @ 2 Ω . This is roughly the same size as the Class A/B 4 channel but twice as much power ... And you get Bluetooth music streaming.

ST-402D BT

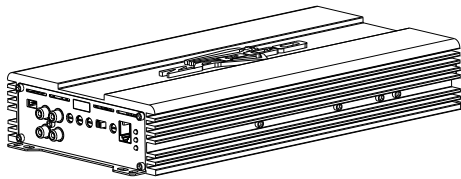

- 2 Channel
- Compact Chassis
- Class D Full Range
- 1,100 Watts RMS
- 550 Watts RMS x 2 @ 2 Ω
- Bluetooth Music Streaming

Features

- Variable Electronic Crossover
- Variable bass boost
- Speaker level OEM Inputs
- Dash mount Remote

The ST-402D BT Controls and connections

ST-402D BT Control end

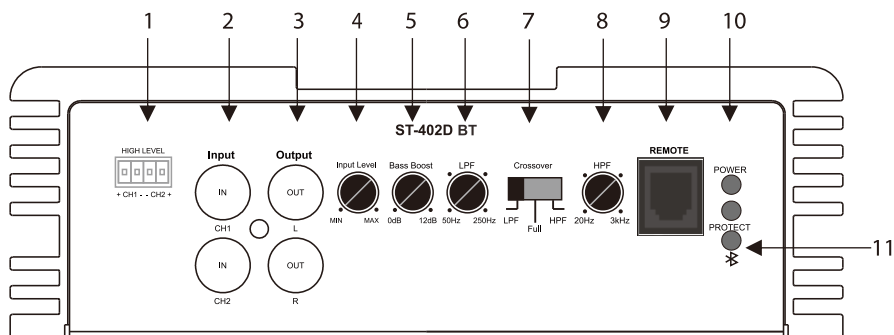

1. Speaker level inputs for OEM integration
2. RCA Preamp input connectors
3. Preamp /Bluetooth output for signal to another amplifier
4. Preamp input level control to balance the amp to the head unit
5. Variable Bass boost selects 0dB to 12dB of boost
6. Low Pass frequency selector for crossover filter
7. Crossover switch to choose Low pass, high pass, or full range output
8. High Pass frequency selector for crossover filter
9. Port for Dash Remote
10. Power/Protect LEDs monitor operating status of the amplifier
11. Bluetooth streaming LED Indicator

ST-402D BT Power end

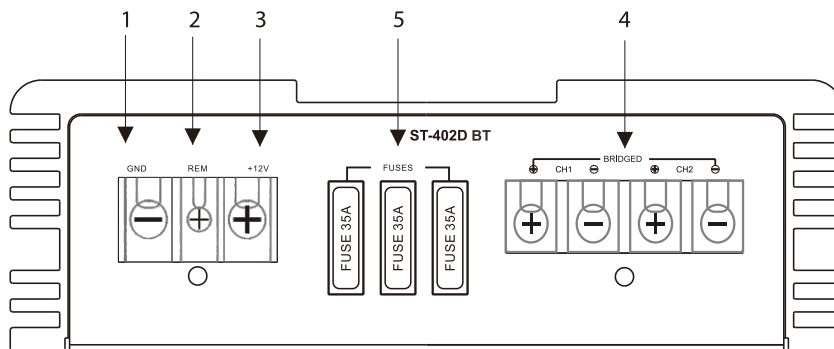

1. GND The amp should have a firm connection the car frame. * See section "Install Sense"
2. REM The remote terminal connects to the head unit remote out, or to some other switched 12 volt source to turn on the amplifier.
3. +12V The main 12 volt must be connected directly to the vehicle's battery using wire of the proper gauge. * See section "Install Sense"
4. Speaker connections The heavy duty terminal block provides positive speaker connections. Simply insert the wire and cinch down the set screw.
Note that the Mono bridge positions are L (Ch1)+ and R (Ch2) - speaker sets
5. **Fuses:** If needed, always replace with the same size fuses

Car Audio Systems

On the following pages we offer some possible system diagrams. These are basic system designs to help you visualize the possibilities of your Zapco Studio-D BT amplifiers.

For these diagrams we used only the Compact chassis amps as they will be easier to visualize.

However all the 4 channel designs using the ST-204D BT can be duplicated exactly with the micro chassis ST-64D BT and ST-104D BT. The only difference is that with the micro chassis amps, the actual connections will be made at the wires and not at the chassis.

Functionally the Micro chassis amps and the Compact chassis ST-204D BT are same.

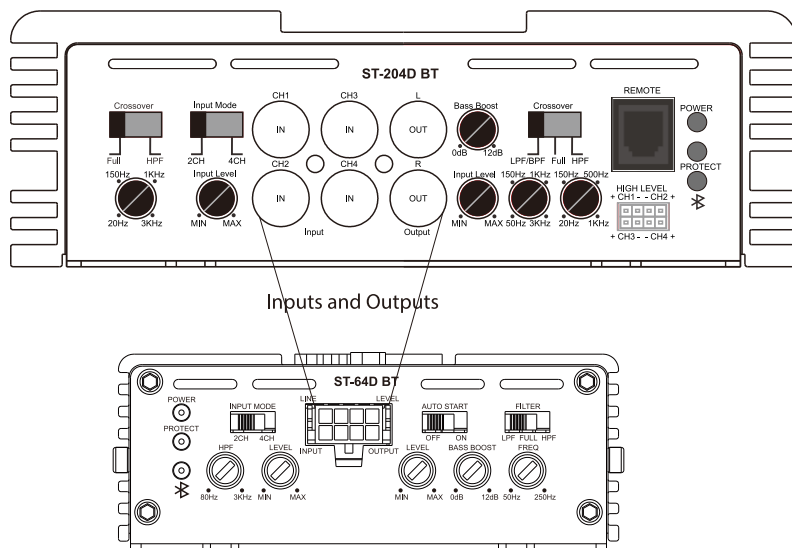

System Diagrams

ST-402D BT

Standard stereo hook-up connects + and - leads from the correct terminal to each speaker, taking care that no wire or speaker terminal makes contact with the metal vehicle body;

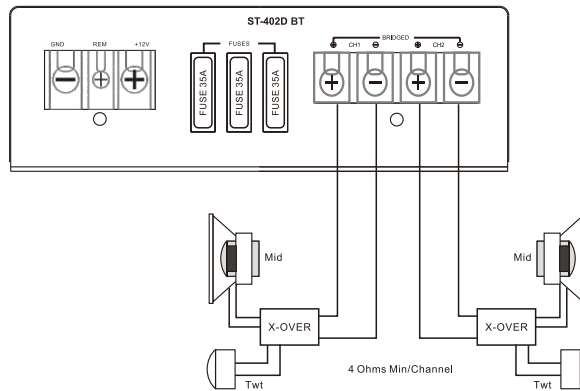

A bridged 3 channel "mixed mono" mode can be used to run Mids/Highs in stereo and a Sub in Mono from the same stereo outputs; To maintain proper impedance you must use passive crossovers (see below) when in mixed mono configuration; A simple Cap/Coil crossover will work for this set-up, placing a coil in the woofer+ lead and caps in the mid/highs leads; See your Zapco authorized dealer for more information on mixed mono setups

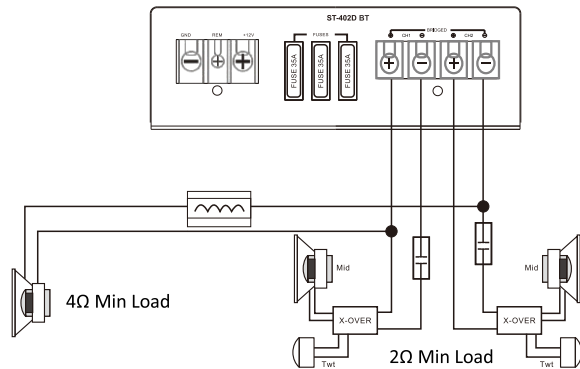

ST-204D BT

Like the ST-402D BT, the ST-204D BT will drive 4Ω or 2Ω loads and can be hooked in 3 channel mixed mono mode; Although the + and - terminals are located slightly differently, the hook-ups are similar

Standard 4 channel system hook-up

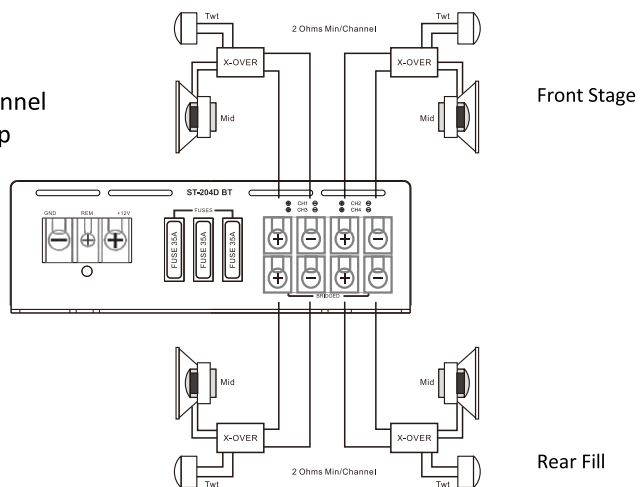

Three way system with front stage, rear stage and subwoofer in mixed mono configuraton

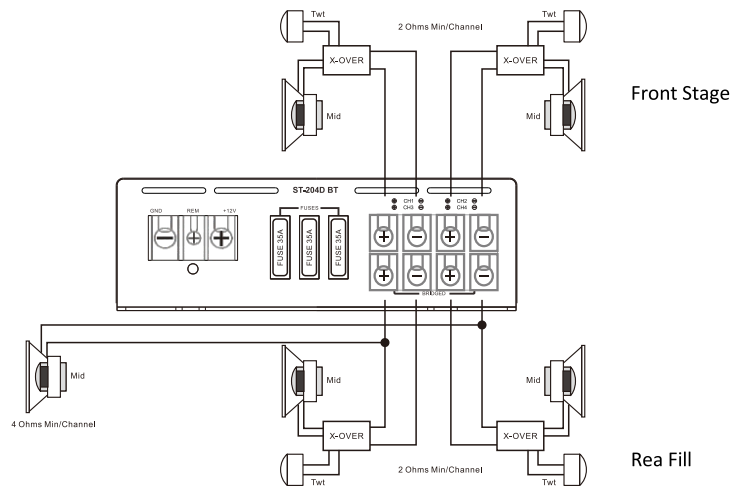

You can create a high power stereo amp by using the ST-204D BT Dual Mono mode where the front amp powers one channel and the rear amp powers the other. You will use Y-adapters to put the Left input into both front channels and the right input into both rear channels.

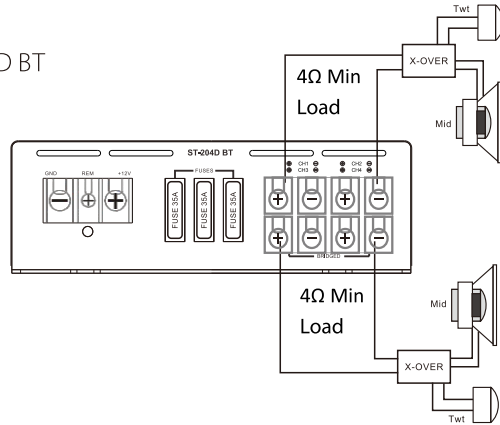

Below, an ST-204D BT drives front and rear speaker, while the 204D BT preout goes to the ST-1650XM inputs and the ST-1650XM drives the subwoofer

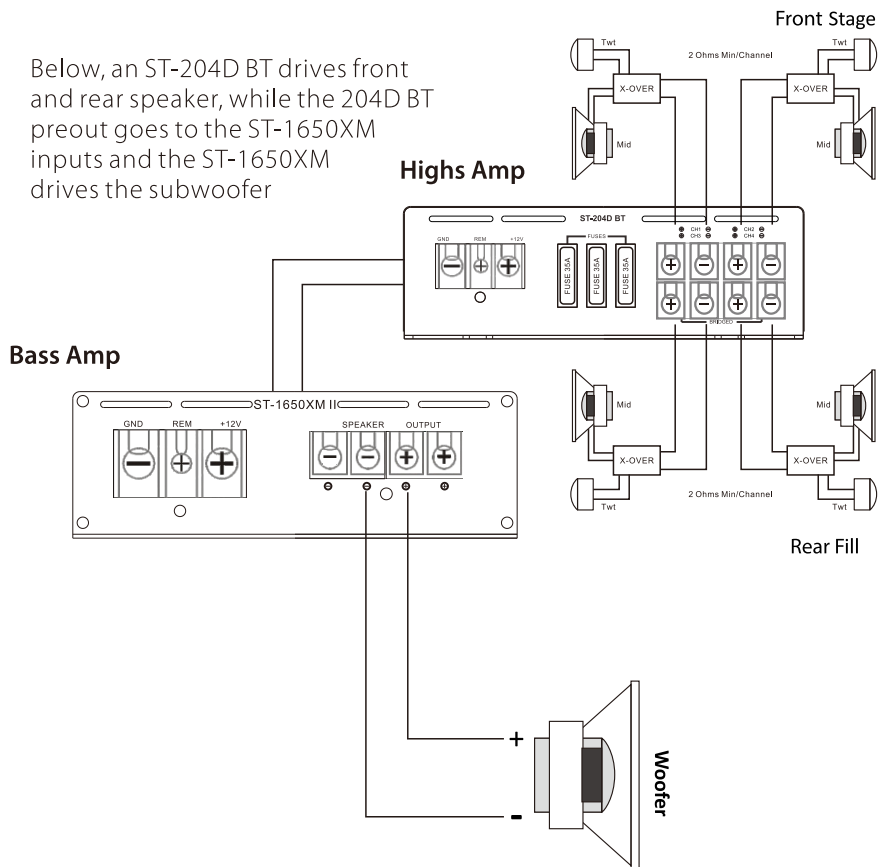

5 Channel Systems

The ST-105D.BT puts everything together in one do-all amplifier

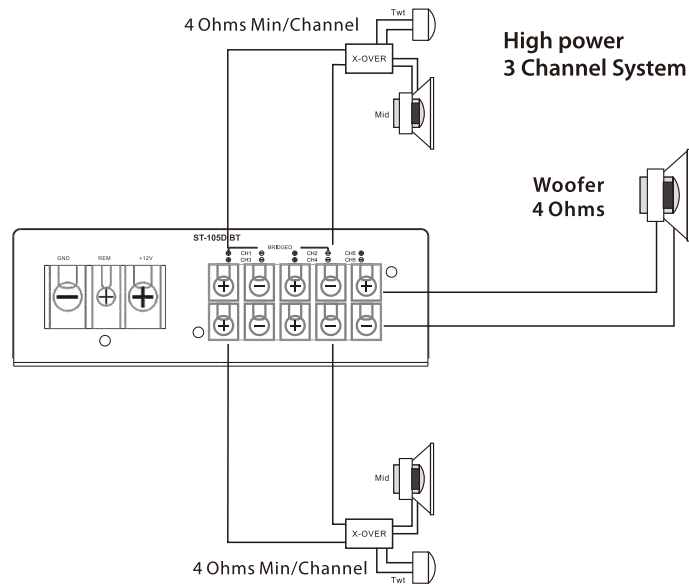
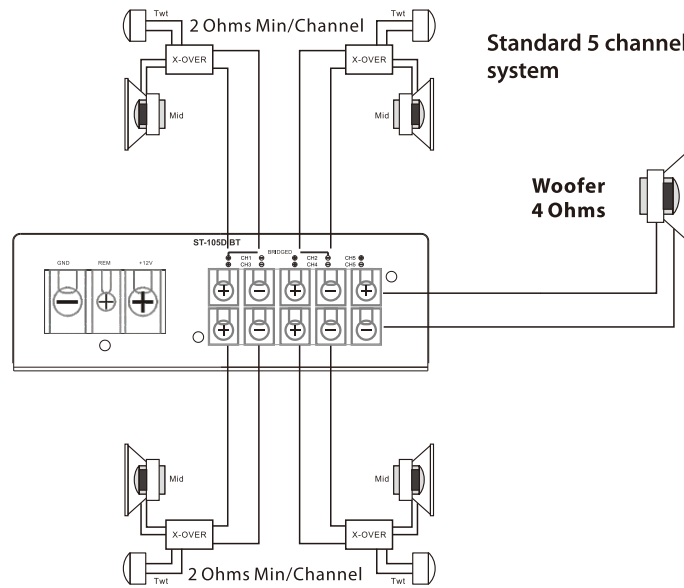

Studio D BT Amplifiers with Bluetooth Music Streaming

AMPLIFIER MODEL	ST-64D BT	ST-104D BT	ST-204D BT	ST-105D BT	ST-402D BT
Class	D	D	D	D	D
RMS Power/Channel At 4 ohms	60W/Ch	85W/Ch	180W/Ch	90W/ChX4+250W	360W/Ch
At 2 ohms	85W/Ch	115W/Ch	280W/Ch	180W/ChX4+350W	550W/Ch
Bridged At 4 ohms	150W/CHX2	230W/CHX2	560W/CHX2	360WX2+350W	1100W
Efficiency	90%	90%	90%	90%	90%
Frequency Response	10Hz~22KHz	10Hz~22KHz	10Hz~22KHz	10Hz~22KHz	10Hz~22KHz
THD at rated power	<0.5%	<0.5%	<0.5%	<0.5%	<0.5%
Signal to Noise	85dB	>85dB	>85dB	>85dB	>85dB
Tested Voltage	14.4V	14.4V	14.4V	14.4V	14.4V
Channel Separation	50Db	50Db	50Db	50Db	50Db
Recommended Fuse Rating	40 Amps	60 Amps	120Amps	90Amps	100Amps
Variable Gain Control	Yes	Yes	Yes	Yes	Yes
Crossovers	Yes	Yes	Yes	Yes	Yes
Bass Boost	Yes	Yes	Yes	Yes	Yes
Dash Remote	Yes	Yes	Yes	Yes	Yes
Preamplifier output	Yes	Yes	Yes	Yes	Yes
RCA Input Sensitivity	220mV~6V	220mV~6V	220mV~6V	220mV~6V	220mV~6V
High Level Spkr Input	Yes	Yes	Yes	Yes	Yes
4-way Protection Circuits	Yes	Yes	Yes	Yes	Yes
Dimensions(mm) L/W/H/	213X95X35.5	242X95X35.5	310X160X52	300X160X52	300X160X52
Dim.(mm) with terminals	237X95X35.5	267X95X35.5	342X160X52	342X160X52	335X160X52

The pursuit of perfection never ends!

No sooner do we produce an new amplifier, then we're looking for a way to make a better one.

In the same way, you're going to find yourself listening to your system and wondering how you can make it sound better.

So, here's your next step: Equalization! Your car changes the sound of your system. The shape of the car, the interior, even the number of passengers. Here's another fact. **No 2 cars are identical.** What's this mean?

That means that to sound it's very best, every system must be matched to the vehicle through Equalization.

To get the very best sound from **your** system in **your** car on **your** music, you need an equalizer.

The Zapco ASP-Q1 is the quickest way to get exactly what you want from your system in your car.

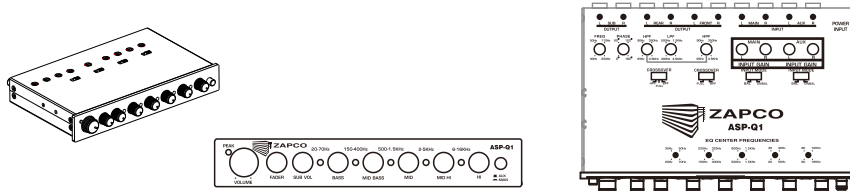

The Zapco ASP-Q1 give you 5 bands of parametric equalization so you can adjust exactly the frequencies needed to tune your system in your car. It also gives you a choice of 2-way or 3-way crossovers, an Auxiliary input, input gains for each channel of each input, a phase control to perfectly match the woofer to the car, a dedicated subwoofer level control, and a system volume control.

The ASP-Q1 id a full system preamp for tuning your system to your car.

To make sure you get that custom tuned sound without added noise, we wrapped the ASP-Q1 in a genuine copper chassis for maximum noise rejection and we gave it a remote mounted power supply in it's own copper chassis.

Audition a Zapco ASP-Q1 Equalizer at your Zapco dealer today

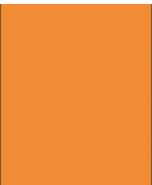

zapco.com