



**Z- SERIES**

**LX**

**AMPLIFIERS**

**Owners Manual**

Before operating the unit,  
please read this manual thoroughly  
and retain for future reference

# **MISSION STATEMENT**

## **Committed to Excellence**

ZAPCO is dedicated to the pursuit of audio fidelity. Our prime objectives are to design and manufacture audio products of unsurpassed quality, to provide unparalleled support and service for these products and to conduct business in a manner that will enhance the quality of life for all involved.

## **Experience**

### Knowledge from doing

There is absolutely no substitute for experience; that is a simple fact of life. Another simple fact is that ZAPCO has, for over forty years, been the leader in defining quality standards for the car audio industry. These years of experience have led to a thorough understanding of the challenges that are unique to the world of car audio. ZAPCO's relentless quest for sonic purity consistently yields imaginative designs that utilize the most innovative technologies. The resulting products set the criteria by which all others in the industry are judged.

## A NEW STANDARD IN SOUND QUALITY

**Congratulations**, on the purchase of your new limited edition Zapco Z-Series LX amplifier. We believe you now have the finest sound ever available in a production car sound amplifier, and we think you should know a little bit about what makes this amp unique in a world of so many so-so products.

**The birth of the Zapco LX Series amplifiers.** In 2012 Zapco introduced the new Z-Series of SQ amps. These amps were not conceived so much by our engineers, as by input from audiophiles and car sound fanatics around the world. Starting about 2004, at Zapco training seminars in Asia and in the EU, we began running into audiophiles who were changing certain internal components in our amplifiers to achieve what they felt was better quality sound.

The seed of an epiphany was planted one day in a heated discussion about amplifier specs when a highly respected audiophile said "maybe your amps are too fast". Our reaction was immediate. Too fast" Ridiculous! An amp can't be too fast. But, as time went on, we began to discuss the possibility that we had chased the specifications to the point that we were no longer improving the sound. While engineering is critical to amplifier performance, it is not the whole story.

For example: If people cannot hear the effect of damping beyond about 200, why do we take it to 1000, or even higher? How does taking specs to the extreme effect other aspects of sound? So for the Z-Series of Zapco amplifiers, we experimented with internal components to see if we could take our amps to the next level of sound quality by investing in different internal components.

What we found was that electrolytic caps, Mylar caps, and tantalum caps all sound different. Different op-amps sound different...even if they have the same engineering specs. Output devices all sound different even though they put out the same voltages. Even the layout

of components on a board will affect the sound of an amplifier. And ultimately, we found that different combinations of op-amps, capacitors, and output devices allowed us to make a major difference in the sound quality of the amplifiers without changing the specs. The Z-Series amplifiers used a combination of high end op-amps, capacitors, and high speed output devices to bring you what we believed were the best sounding amplifiers we had ever offered.

And the competition world, and reviewers, agreed. The amps were compared to the best of McIntosh and Bryston home amps. Audio Competitors around the world sought out the Z-series amps to help put them at the top of the field. We saw the results in First Place trophies in MECA, IASCA, EMMA, and other contests. There had never been an amp like the Z-Series.

So the question for us for 2014 was ... "What can we do to make the sound even better". How could we take sound quality to a level beyond the Z-Series?

The Answer? The New Zapco Z-150.2 LX , Z-150.4 LX ,Z-150.6 LX and Z-400.2 LX. LX is not just a pretty plaque on last year's amp. These are amps with all stops pulled out.

What did we do to improve on the sound the Z-Series?

First we supercharged the power supply. We tightly regulated the massive power supply. We then boosted efficiency of the power supply with higher switching frequencies, bigger FETs, and more storage capacitance. We increased the output filtering as well. This is the highest efficiency power supply we've ever had. We regulated every voltage in the amplifier, from the fully regulated power supply to the regulators on the preamp voltages.

We improved the muting circuitry to prevent any on/off noises. We put bypass caps everywhere in this amp so you'll never have to worry about voltage spikes affecting the sound quality. We used only top end Elna, Nichicon, and Panasonic electrolytic caps in the power supply and in the preamp section. Low value caps are Mica and Polypropylene. Only the best for the LX.

We re-designed the board for better signal path, and eliminated any op-amps and circuitry that were not needed, so we could shorten the signal path. In doing this we removed crossovers, bass boosts and anything else that could detract from the sonic purity of the product.

The new LX amplifiers are no-holds-barred sound quality amplifiers. There has never been a production amp like this!

When you first light up your new amp you'll be amazed by the clarity and purity of the sound. But just wait...it only gets better. As this amp burns in over the first hundred or so hours of use, it will just get better and better each time you turn it on.

We hope you enjoy your new Z-Series LX amplifier as much as we enjoyed the time we spent developing it.

## WARNINGS

ZAPCO highly recommends that a fuse or circuit breaker be placed within 18" of the battery. Although products have adequate internal protection, it is possible that a pinched power wire between the component and the battery may result in a fire. The protection device should be placed where it can be accessed easily and all wiring should be routed safely and correctly according to the following guidelines:

Do not run wiring close to hot or spinning objects.

Always use wire grommets when routing wire through the firewall or any other metal panels.

Make sure that the potential for pinched wiring is avoided by routing all wires away from moving hinges and seats. This also includes brake, gas and clutch pedals, hood and trunk hinges, etc.

### Caution:

**Continuous exposure to excessive sound pressure levels may cause permanent hearing loss. ZAPCO strongly advises that you use common sense when setting volume levels. If you experience ringing in the ears, it could cause permanent hearing damage!**

### Caution:

When connecting our amplifiers to pre-wired stock speakers, care must be taken that there are no common connections between left and right speaker wires, i.e. minus to minus or plus to plus connections, as this will cause the amplifier to go into immediate protection or may cause damage to the amplifier. Output connections are not common chassis ground. Please follow the hookup instructions in this owner's manual. Any questions should be directed to your local ZAPCO dealer.

## WIRE SIZE

Most people understand the importance of a clean signal source for good sound reproduction. But, what about your 12 volt power source? It's often surprising how many people (even professional car audio people) will obsess about signal wire but routinely provide the amplifier only a fraction of the current it needs to do its job. The most common wire gauge used in car audio is 10-gauge. The most common location for amplifiers is in the trunk.

Take a look at the chart below. If you want to have any respectable amount of power for your amp, you need an 8-gauge wire to the trunk as a bare minimum. If you want enough power to drive woofers, you're going to need at least a 4-gauge wire to the rear.

---

Current Demand	Length of Run							
	0- 4 Ft	4- 7 Ft	7- 10 Ft	10- 13 Ft	13 - 16 Ft	16 - 19 Ft	19 - 22 Ft	22- 28 Ft
0 - 20 amps	14	12	12	10	10	8	8	8
20 - 35 amps	12	10	8	8	6	6	6	4
35 - 50 amps	10	8	8	6	6	4	4	4
50 - 60 amps	8	8	6	4	4	4	4	2
65 - 85 amps	6	6	4	4	2	2	2	0
85 - 105 amps	6	6	4	2	2	2	2	0
105 - 125 amps	4	4	4	2	2	0	0	0
125 - 150 amps	2	2	2	2	0	0	0	0

Lets look at a fairly small system. If you use a 50 watt/ch amp (25 amps) for the highs and a 100 watt/ch amp (40 amps) for the woofers, you need at least a 4-gauge wire to provide 65 amps at the trunk. Anything less and your car won't go boom. It'll just go Blap!

### **It takes lots of current to make lots of power!**

And remember! An electrical circuit is just that...a circuit. For current to travel, you must complete the circuit from the positive terminal to the negative terminal.

Whatever you use for power (B+) you must also use for Ground (B-). 4-gauge power wire needs 4-gauge ground wire!

So! Use this supplied chart! Add up the fuse values on the amplifier(s) then choose the proper size wire based on the distance from the car battery to the amplifier location. Very important, always use the same gauge wire for the main ground as you do for the main power. Always make your ground as short as possible and attach to a clean solid surface.

### **Installing your Z-Series LX Amplifier**

Mounting your Zapco amplifier is easy. Just keep in mind a few guidelines:

- The amplifier can be mounted in any direction, on wood, metal, or carpet.
- The metal chassis of the amp can be grounded or left isolated.
- The amplifier requires adequate ventilation. Creating power creates heat. Position the amplifier with sufficient surrounding area for proper cooling.
- Keep the end plate vents clear for internal cooling
- Keep the amplifier out of the engine compartment or other locations that may cause excessive heat or moisture
- **Do not mount the amplifier to a subwoofer box or other place that may have excessive vibration**



# DESIGN FEATURES AND SPECIFICATIONS

## ■ Z-SERIES LX AMPS

- Class-AB bridgeable 12V amplifier
- Ultra high speed PWM MOSFET power supply
- Stable into 4 ohms bridged or 2 ohms stereo load
- Tightly regulated from 11.5V to 14.5V
- Variable input sensitivity for each channel
- Tiffany style RCA Signal input and output connectors
- 4-way protection circuitry  
(thermal / over current / speaker short / DC)
- Tested voltage & THD: 11.5V~15V & less than 0.05% THD at rated power
- Operating voltage:DC10V~15.5V power input

## SPECIFICATIONS OF THE Z-SERIES LX AMPLIFIERS

	<b>Z-150.2 LX</b>	<b>Z-150.4 LX</b>	<b>Z-150.6 LX</b>	<b>Z-400.2 LX</b>
Rated power output				
-RMS power, 4 ohms stereo	150W x 2CH	150W x 4CH	150W x 6CH	400W x 2CH
-RMS power, 2 ohms stereo	250W x 2CH	250W x 4CH	250W x 6CH	600W x 2CH
-RMS power, 4 ohms bridged	500W x 1CH	540W x 2CH	500W x 3CH	1200W x 2CH
Signal to Noise Ratio	>90dB	>90dB	>90dB	>90dB
Frequency Response	10Hz ~ 30KHz (+ / - 1dB)	10Hz ~ 30KHz (+ / - 1dB)	10Hz ~ 30KHz (+ / - 1dB)	10Hz ~ 30KHz (+ / - 1dB)
THD@RMS Watts	0.05%	0.05%	0.05%	0.05%
Channel Separation	>50dB	>50dB	>50dB	>50dB
Fuse Rating	35A x 2	Recommened 150A	Recommened 100A	Recommened 150A
Input Sensitivity	200mV~8V (+ / - 5%)	200mV~8V (+ / - 5%)	200mV~8V (+ / - 5%)	200mV~8V (+ / - 5%)
Dimensions(inches)	7.48(W) x 2.46(H) x 12.83(L)	7.48(W) x 2.46(H) x 18.82(L)	7.48(W) x 2.46(H) x 25.12(L)	7.48(W) x 2.46(H) x 20.31(L)

# RCA CONNECTION

## ■ Z-150.2 LX

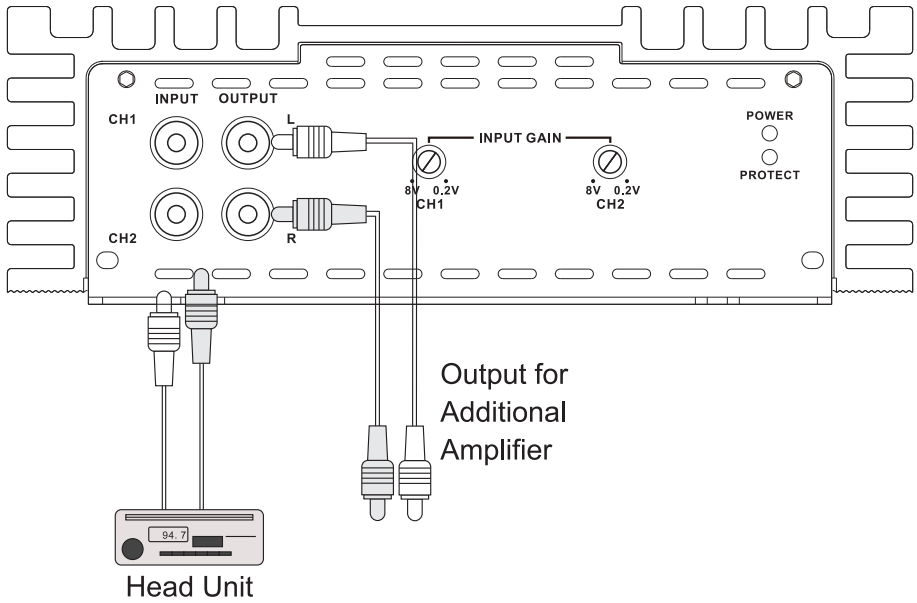

# POWER CONNECTION

## ■ Z-150.2 LX

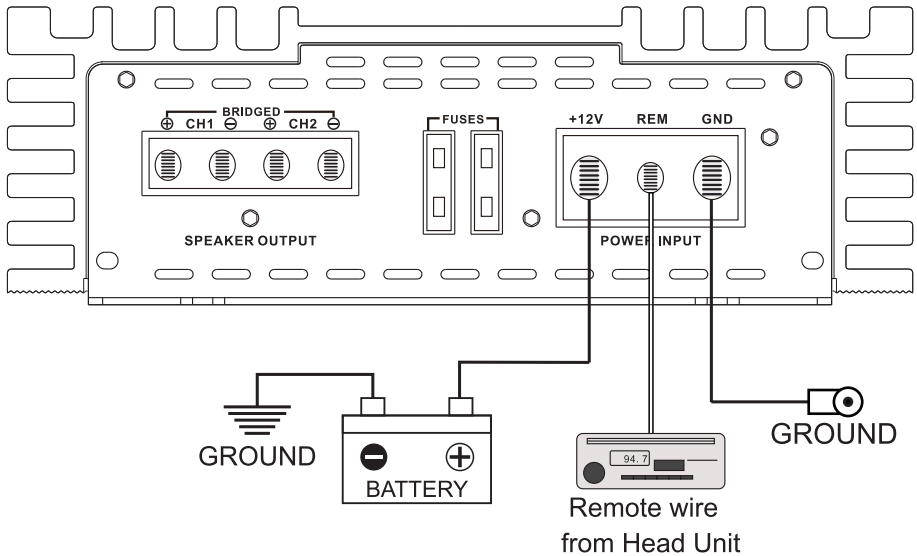

## RCA CONNECTION

### ■ Z-150.4 LX

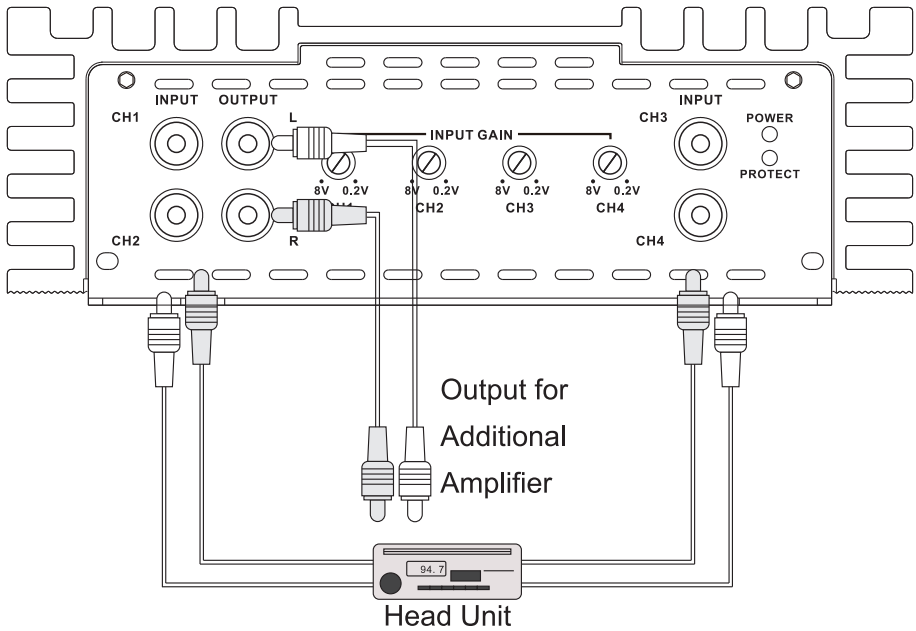

## POWER CONNECTION

### ■ Z-150.4 LX

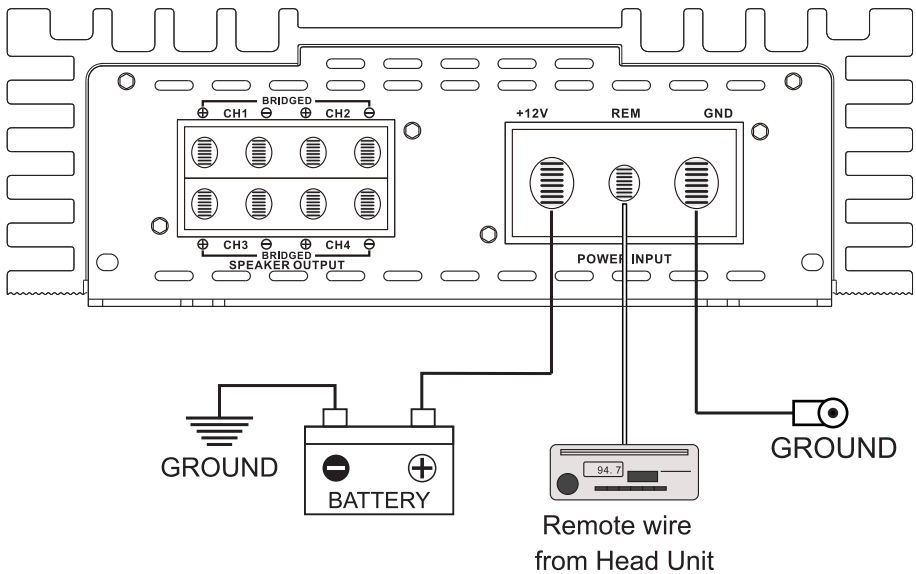

# RCA CONNECTION

## ■ Z-150.6 LX

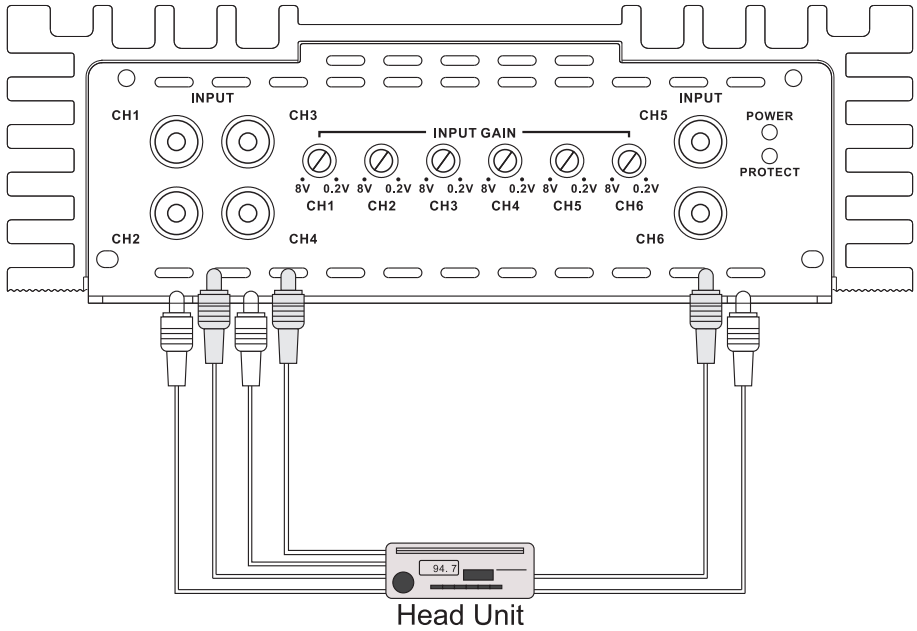

# POWER CONNECTION

## ■ Z-150.6 LX

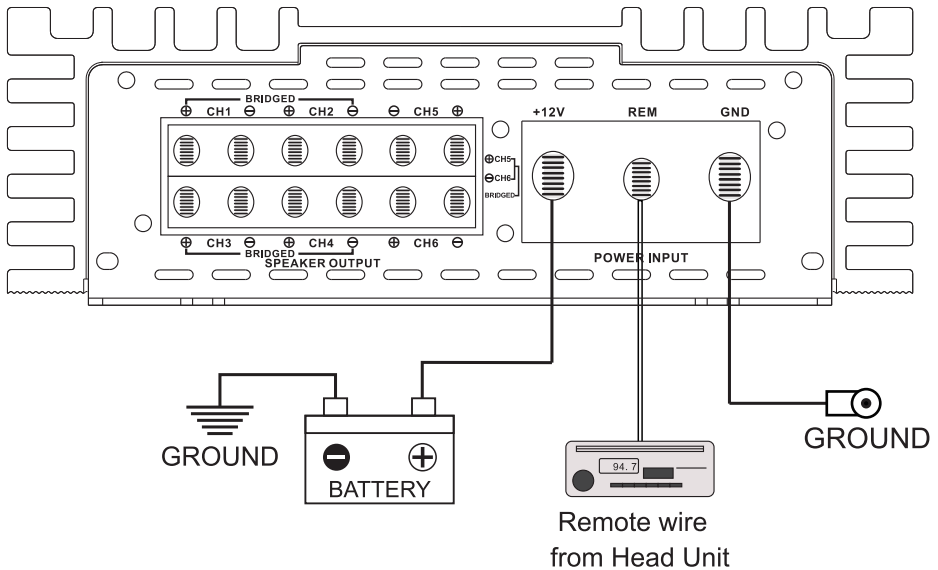

# RCA CONNECTION

## ■ Z-400.2 LX

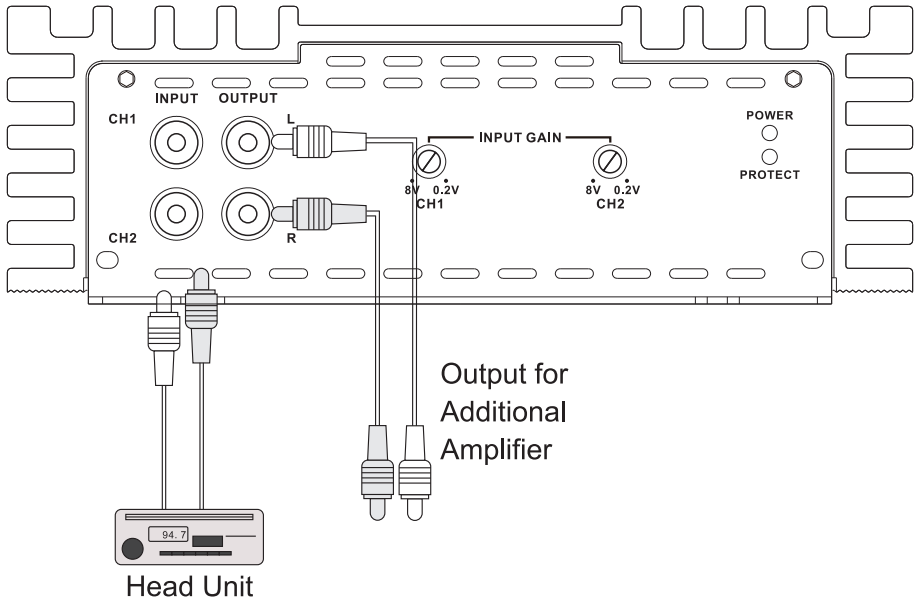

# POWER CONNECTION

## ■ Z-400.2 LX

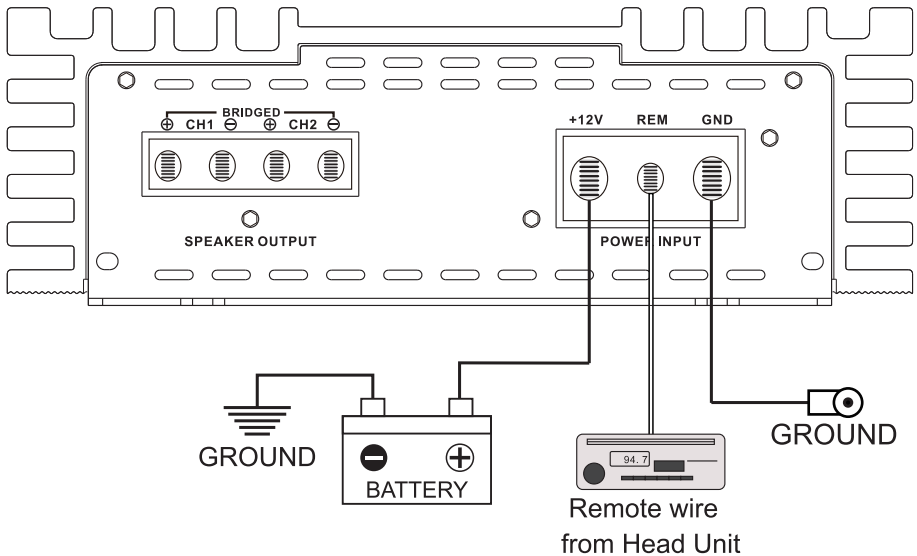

## POWER CONNECTION

### +12V POWER

**Disconnect the battery ground.** connect the +12V terminal of the amplifier to the + terminal of the battery using the appropriate gauge wire cable. **Always use the same gauge wire for power and Ground.** Install an in-line fuse holder, within approximately 14" of the + terminal of battery.

### GROUND

Connect the GND (ground) terminal to the cars frame

of chassis keep this cable as short as possible and make sure that the connection with the fram or chassis is rust free and clear of paint or grime. Any ground connection should be at the frame or a part with direct connection to a major frame component.

### REMOTE

Connect the REM terminal of the amplifier to the 12V trigger output of the source unit or a car accessory terminal at the fuse box or ignition switch using appropriate gauge wire.

### **Caution**

**After all electrical connections are made:** You may re-connect the battery ground. Always use recommended fuse ratings. Wire must always be fused at the battery for protection against possible damage to the vehicle. If you need to replace the power fuse, replace it with a fuse of the same value.

# SPEAKER CONNECTION

## ■ Z-150.2 LX

### 1 Channel Bridged

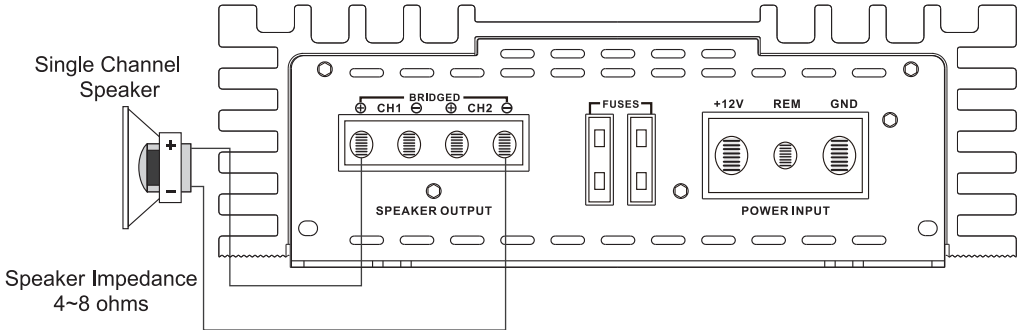

### 2 Channel Stereo

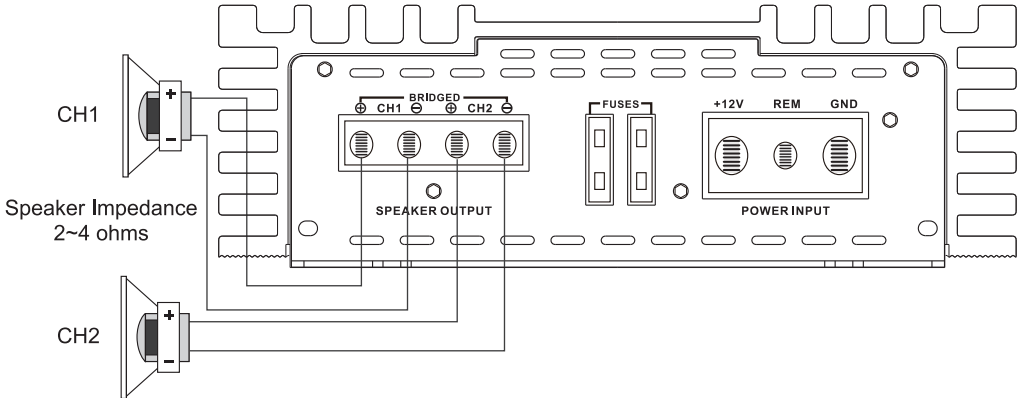

### 3 Channel Tri Mode

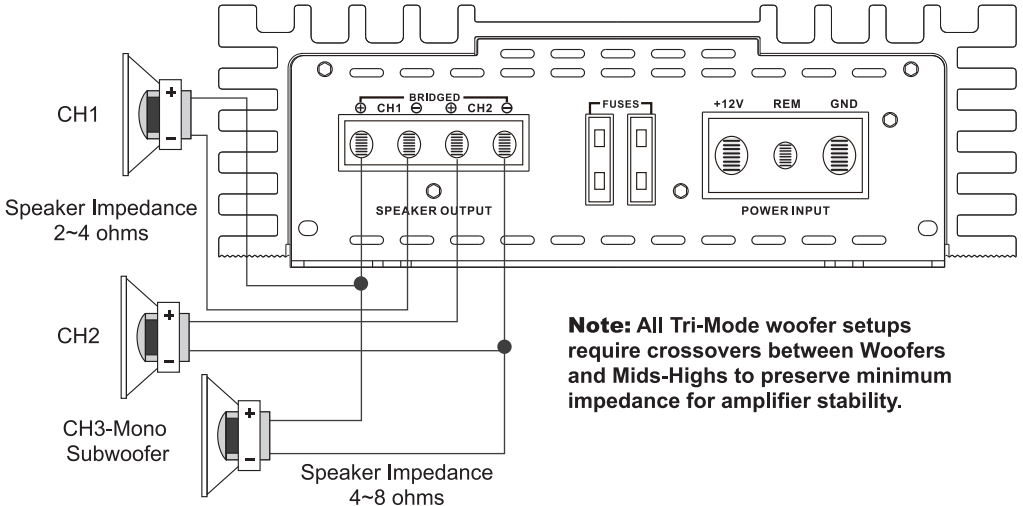

# SPEAKER CONNECTION

## ■ Z-150.4 LX

### 2 Channel Bridged

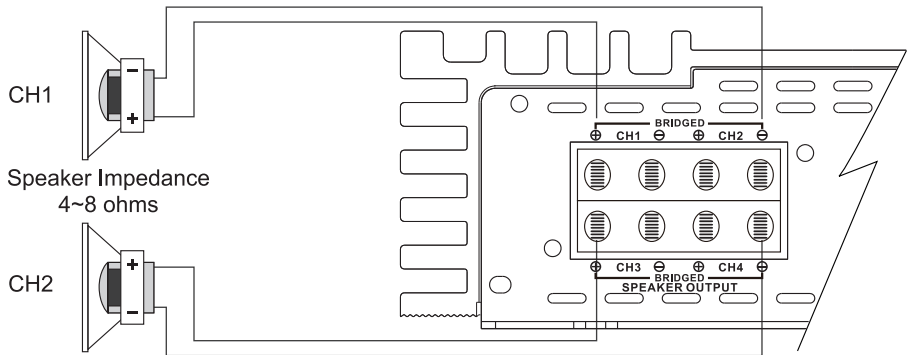

### 4 Channel Stereo

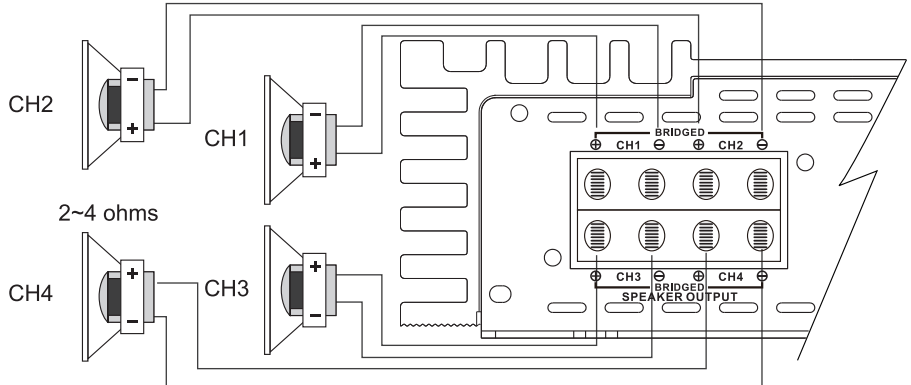

### 6 Channel Tri Mode

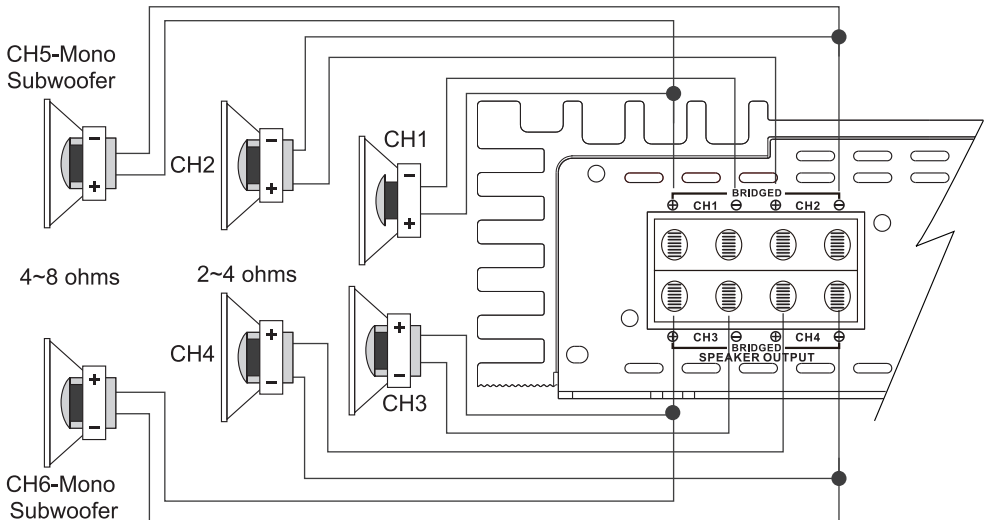



# SPEAKER CONNECTION

## ■ Z-150.6 LX 3 Channel Mode

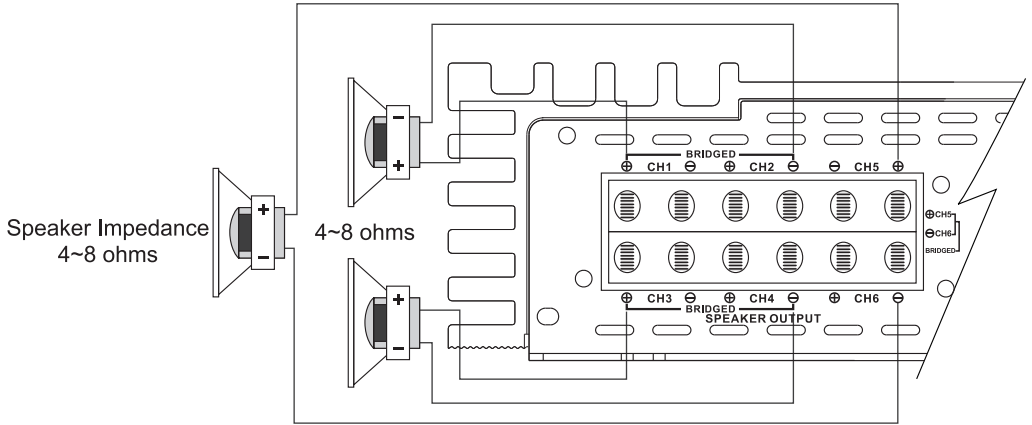

## 2 Channel Stereo w / 2 woofers

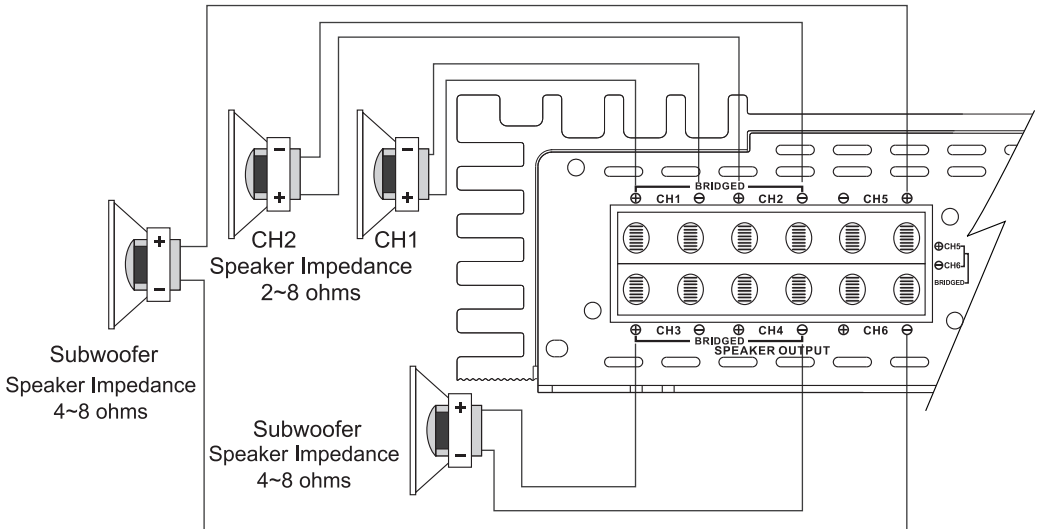

# SPEAKER CONNECTION

■ Z-150.6 LX

2 Channel Bridged

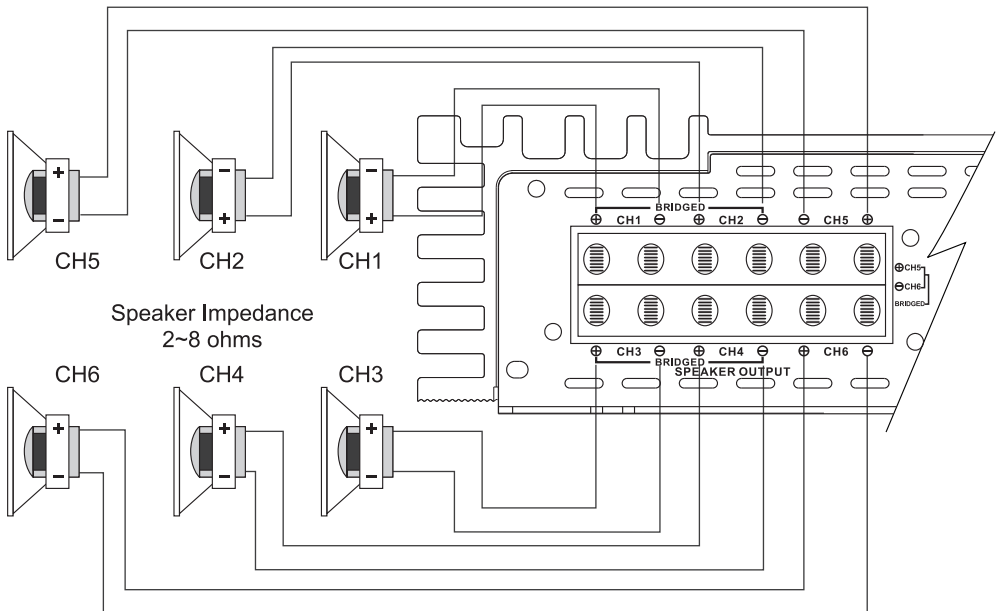
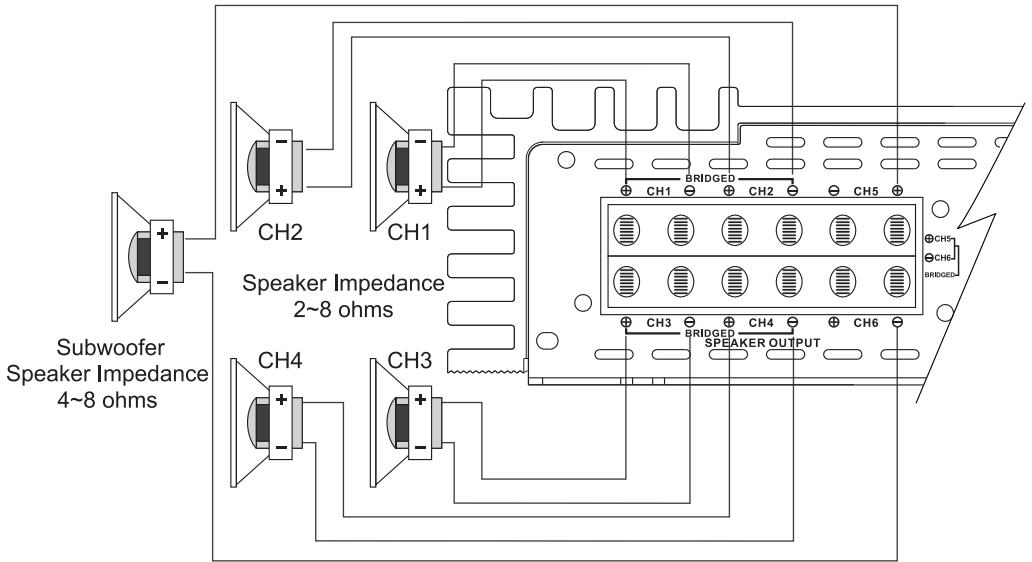

# SPEAKER CONNECTION

## ■ Z-400.2 LX

### 1 Channel Bridged

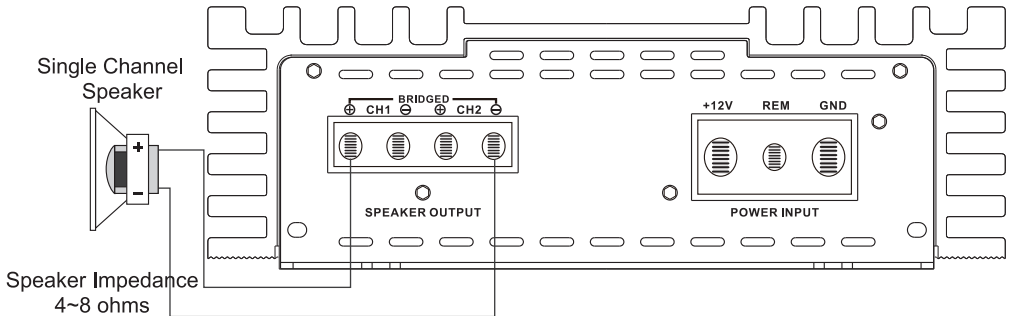

### 2 Channel Stereo

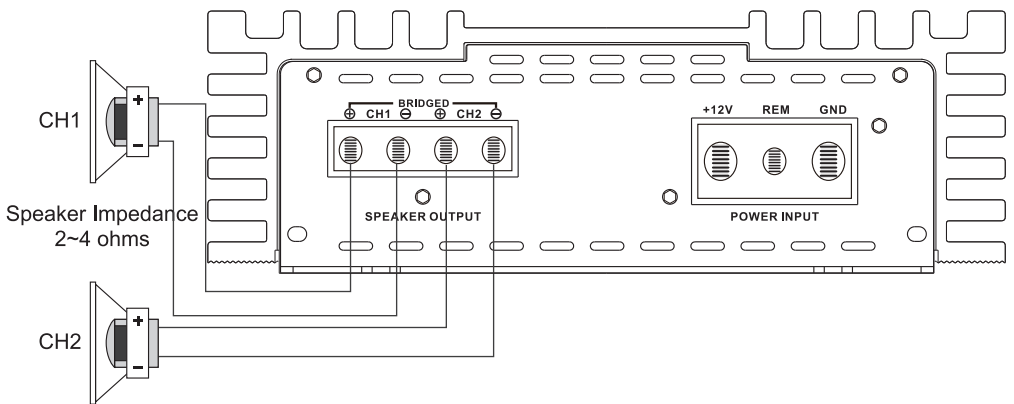

### 3 Channel Tri Mode

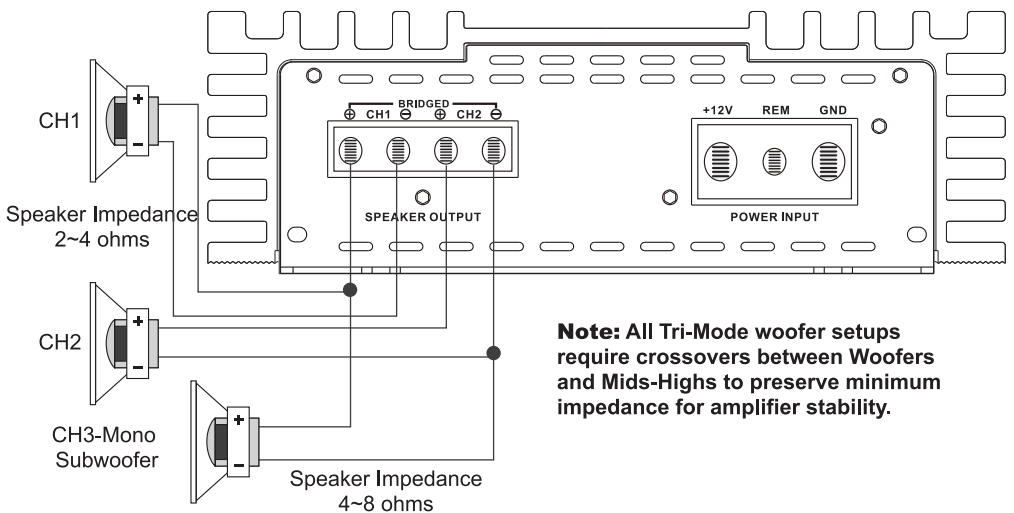

**Note: All Tri-Mode woofer setups require crossovers between Woofers and Mids-Highs to preserve minimum impedance for amplifier stability.**

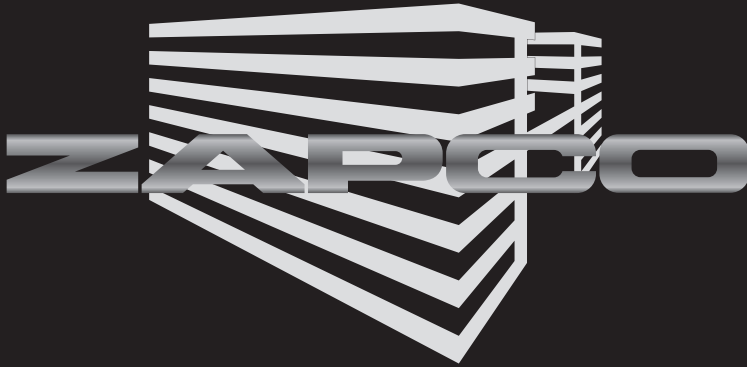

Zapco  
Modesto, California, USA  
Since 1974 [www.zapco.com](http://www.zapco.com)  
Contact: [info@zapco.com](mailto:info@zapco.com)

Zapco is a registered trademark  
of ARPA of America Corporation