

IRIDIUM-SERIES VERSTÄRKER

ANLEITUNG

GZIA 1.300HPX-B

GZIA 1.600HPX-B

GZIA 2080HPX-B

GZIA 2130HPX-B

GZIA 2235HPX-B

GZIA 4115HPX-B

Ausstattungsmerkmale

- 4 Ohm / 2 Ohm stabil Stereo
- 4 Ohm stabil Mono (GZIA 1.300HPX-B)
- 1 Ohm stabil Mono (GZIA 1.600HPX-B)
- Einschalt- und Schutzanzeige
- Bass Boost (GZIA 1.300HPX-B / 1.600HPX-B)
- Hochpass regelbar (GZIA 2080HPX-B / 2235HPX-B / 2130HPX-B / 4115HPX-B)
- Tiefpass regelbar
- Auto-On @ High Level Input
- Regelbare Eingangsempfindlichkeit
- Einschaltverzögerung
- Bass Lautstärkereglер (GZIA 1.300HPX-B / 1.600HPX-B / 2235HPX-B, GZIA 2130HPX-B optional)
- Temperatur / Kurzschluss / Überlast-Schutz

Benötigte Materialien und Werkzeuge zur Installation

- Kreuzschlitz Schraubendreher
- Bohrmaschine, 3 mm Metallbohrer
- Befestigungsschrauben
- Stromkabel min. 10 mm²
- Massekabel min 10 mm²
- Lautsprecherkabel min. 2 x 1,5 mm²

Bitte unbedingt beachten!

- Fahrzeugbatterie vor der Installation abklemmen! (Hinweise in der Betriebsanleitung des KFZ beachten!)
- Keine Löcher in den Tank, die Bremsleitung, Kabel oder andere wichtige Fahrzeugteile bohren!
- Kabel niemals über scharfe Kanten führen. Es ist empfehlenswert, die Stromversorgung der Endstufe mit einem Kondensator (Powercap) min. 1 F zu puffern, um eine stabile Betriebsspannung zu gewährleisten.

WARNUNG !

Hochleistungsaudiosysteme in Fahrzeugen können den Schallpegel eines „Live“ Konzertes erzeugen. Dauerhaft extrem lauter Musik ausgesetzt zu sein, kann den Verlust des Hörvermögens oder Hörschäden zur Folge haben. Das Hören von lauter Musik beim Autofahren kann auch die Wahrnehmung (Warnsignale) beeinträchtigen. Im Interesse der allgemeinen Sicherheit empfehlen wir, beim Autofahren die Musik auf geringer Lautstärke zu hören.

Planung

Vor der Installation sollten Sie folgende Punkte berücksichtigen:

- a) Bitte beachten Sie bei der Wahl des Einbauortes, daß eine ausreichende Luftzirkulation zur Kühlung des Gerätes gewährleistet ist.
- b) Wenn Ihr Radio mit Vorverstärkerausgängen ausgerüstet (RCA) ist, ist es ratsam, diese zu nutzen.

Einbau des Verstärkers

- a) Den passenden Einbauplatz auswählen, zu dem die Leitungen leicht verlegt werden können und an dem es genügend Platz für die Luftzirkulation und Kühlung gibt.
- b) Den Verstärker als Schablone benutzen, um die Einbaustellen zu markieren. Den Verstärker entfernen und 4 Löcher bohren. Den Verstärker mit den vorgesehenen Schrauben befestigen.

Warnung

Bitte diese Systeme so einbauen, dass Elektroanbindungen vor Beschädigungen geschützt sind.

+12 Volt DC Elektrokabel müssen auf der Batterieseite abgesichert sein. Bitte sicherstellen, dass das Radio und andere Geräte ausgeschaltet sind, wenn Sie die Geräte anschließen.

Wenn es notwendig ist, eine Gerätesicherung zu erneuern, verwenden Sie nur eine gleichwertige Sicherung. Wenn eine minderwertigere Sicherung benutzt wird, kann sie Schaden an dem ganzen System verursachen. Dieser ist von der Garantie ausgeschlossen.

Einstellungen und Funktionen – GZ1A 1.300HPX-B

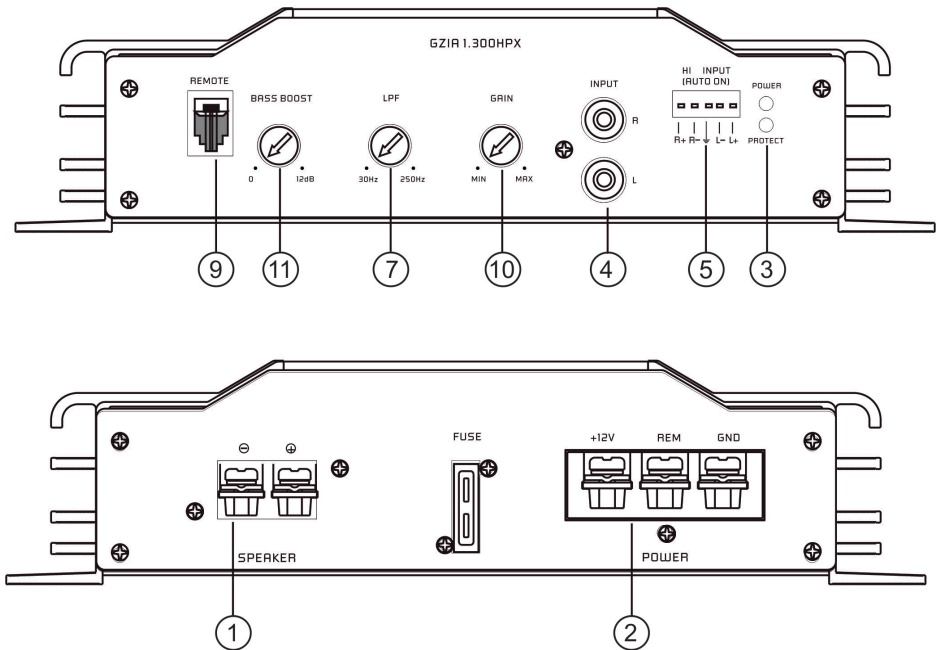

Einstellungen und Funktionen – GZ1A 1.600HPX-B

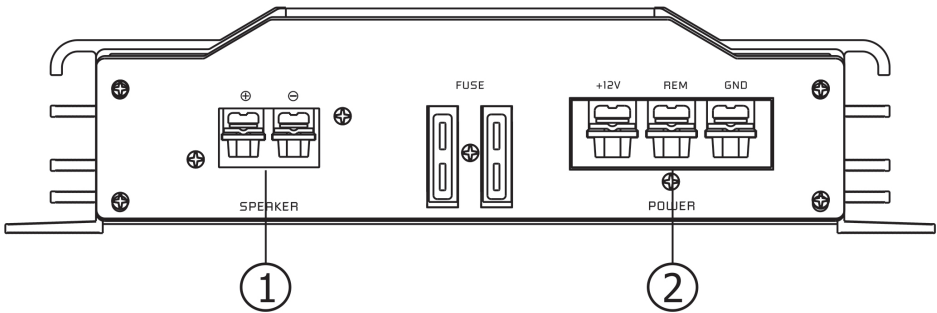
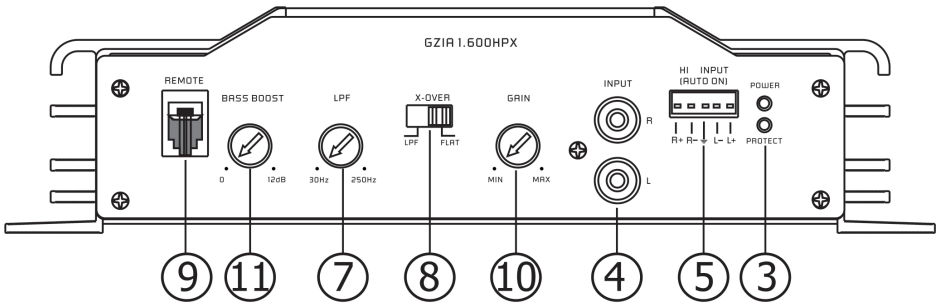

Einstellungen und Funktionen – GZIA 2080HPX-B

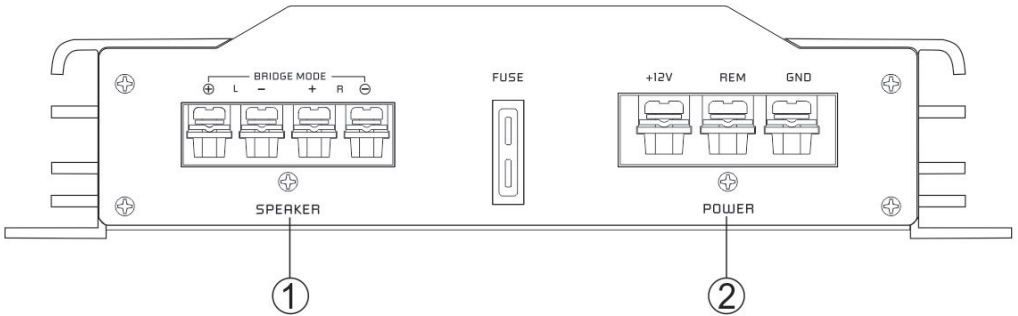
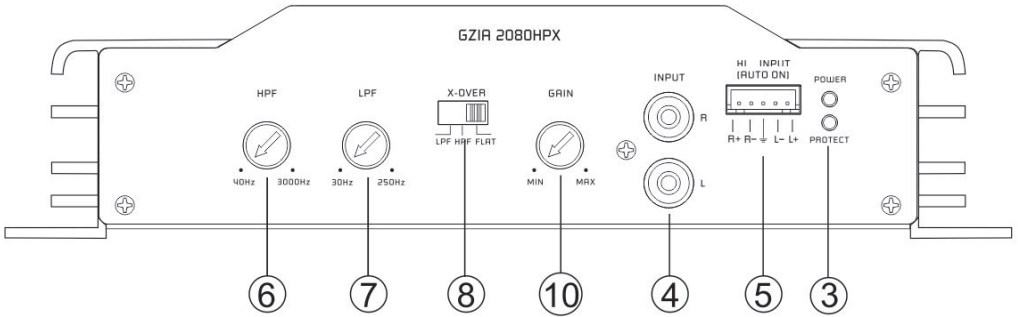

Einstellungen und Funktionen – GZIA 2130HPX-B

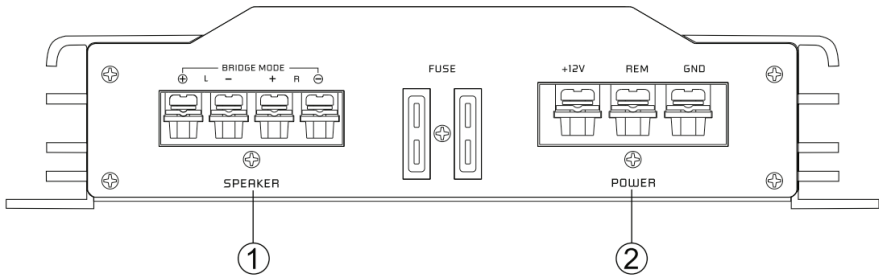
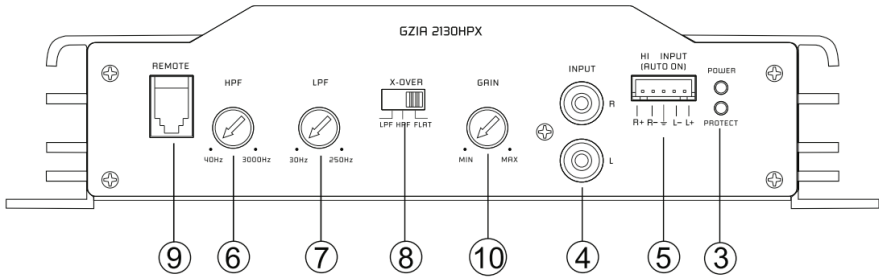

Einstellungen und Funktionen – GZIA 2235HPX-B

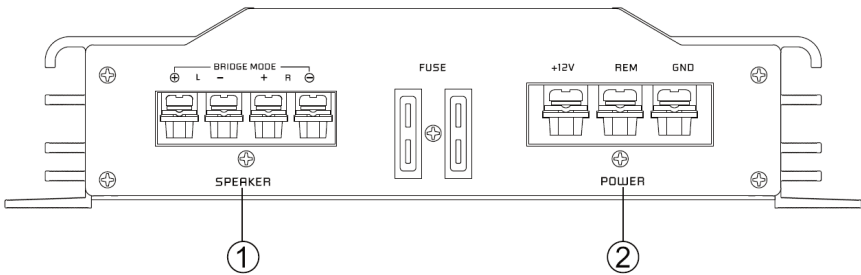
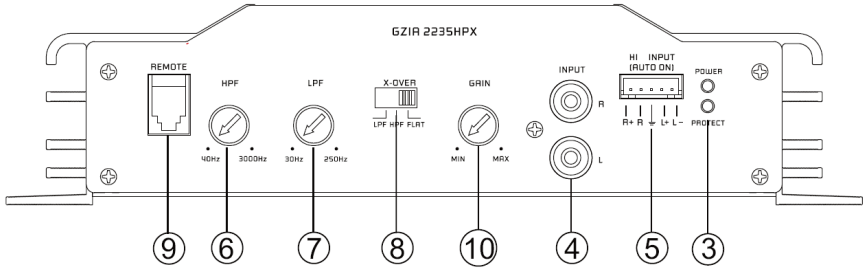

Einstellungen und Funktionen – GZ1A 4115HPX-B

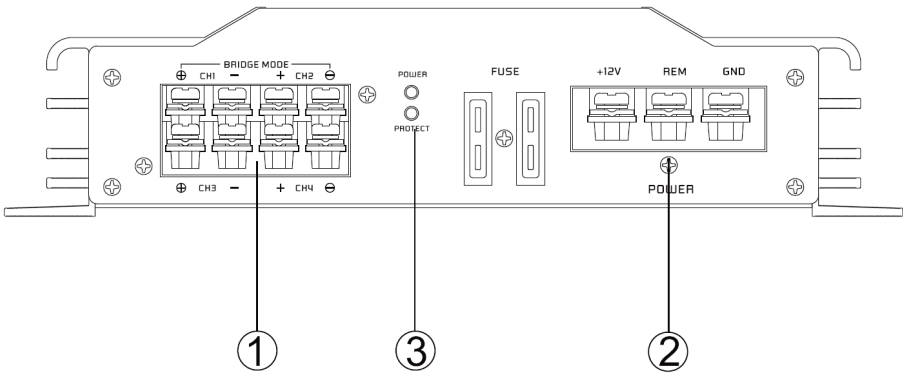
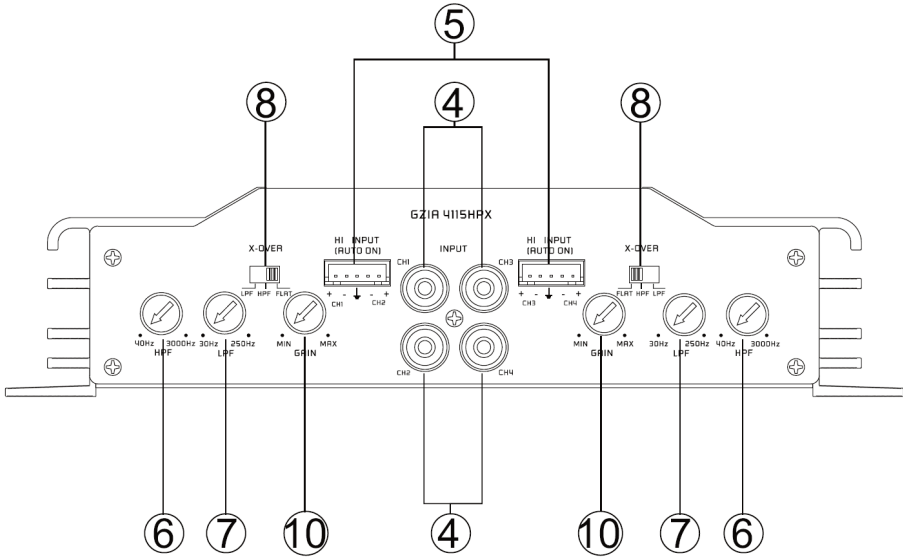

Einstellungen und Funktionen

1	Lautsprecheranschlüsse	Zum Anschluss der Lautsprecher
2	Stromanschluss	GND -> Masse Anschluss REM -> Remote Antennenanschluss [nicht bei Nutzung der High Level Eingänge (5)] BATT -> +12 Volt
3	Zustandsanzeige	GRÜN – OK ROT – Fehler
4	Cinch Eingänge	An diesen Anschlüssen schließen Sie die Cinchleitungen an. Um Störungen zu vermeiden, verwenden Sie bitte hochwertige Cinchkabel. WICHTIG: Betreiben Sie niemals die High Level und die Cincheingänge parallel. Dies kann zu Schäden am Gerät führen. Nutzen Sie entweder die Cinch ODER die High Level Eingänge
5	High Level Eingänge	Diese Eingänge müssen genutzt werden, falls Ihre Steuereinheit nicht über einen Low Level Cinch Ausgang verfügt. Verbinden Sie diesen Eingang mit den Lautsprecherausgängen der Steuereinheit. Die Endstufe schaltet automatisch ein, sobald ein Signal anliegt (Auto-On). Der Remote Anschluss des Strom-Terminals (2) bleibt frei. WICHTIG: Betreiben Sie niemals die High Level und die Cincheingänge parallel. Dies kann zu Schäden am Gerät führen. Nutzen Sie entweder die Cinch ODER die High Level Eingänge
6	High Pass Regler	Setzen Sie den Filter - Schalter auf "HIGH". Justieren Sie die variable HPF Übergangsfrequenz mit dem Regler auf die gewünschte Frequenz. Es werden alle Frequenzen unterhalb 40 - 3000 Hz gefiltert.
7	Low Pass Regler	Es werden nur noch Frequenzen unterhalb von 30 – 250 Hz wiedergegeben (abhängig von der Reglerstellung des LPF Filters). Setzen Sie den Filter - Schalter auf "LOW". Justieren Sie die variable LPF Frequenz mit dem Regler auf die gewünschte Frequenz.
8	Mode Schalter	Stellen Sie die Weiche für die ausgewählte Anwendung ein. LPF - Nur Bassfrequenzen (unter 30 – 250 Hz) werden wiedergegeben. FLAT - Alle Frequenzen werden übertragen. HPF - Nur mittlere und hohe Frequenzen (über 40 – 3000 Hz) werden übertragen.
9	Remote Control Eingang	Zum Anschluss des Bass Lautstärkereglers. (GZIA 2130HPX/2235HPX/1.600HPX)
10	Gain Level Regler	Hier justieren Sie die Eingangsempfindlichkeit des Verstärkers
11	Bass Boost	Zur Regelung einer Bassanhebung bei 45 Hz von 0 – 12 dB

High Level Input

Bei Benutzung der High Level Eingänge kann es je nach Anlagen und Fahrzeug-Konfiguration zu Störgeräuschen kommen.

Bitte nutzen Sie den mittleren zusätzlichen Masse-Anschluss dieses Eingangs, um diese Geräusche zu verringern, ggf. sogar komplett zu unterbinden.

Die Auto-On Funktion erlaubt Ihnen, den Verstärker ohne zusätzlichen Remote-Anschluss zu betreiben. Dies ermöglicht u.a. den Betrieb an OEM Headunits und OEM Aktivsystemen, welche weder über Cinchausgänge, noch über einen geschalteten Remote-Ausgang verfügen.

High Level Input – GZIA 1.300HPX-B

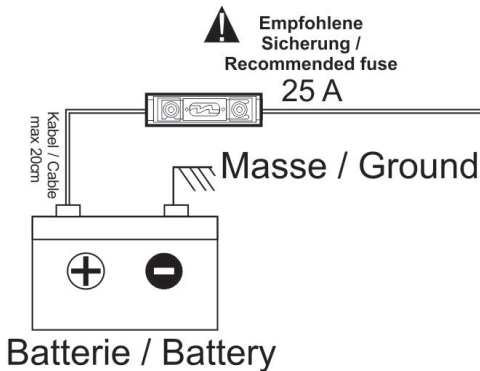
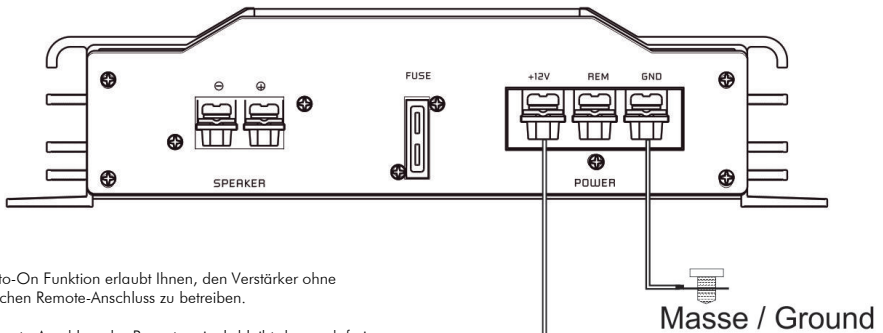
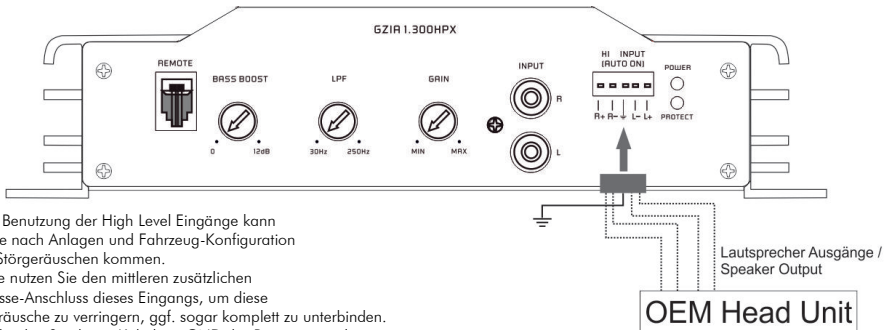

High Level Input – GZ1A 1.600HPX-B

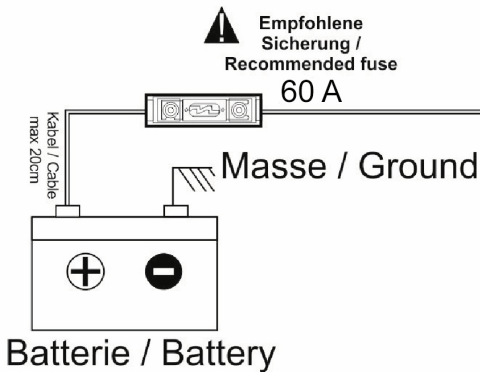
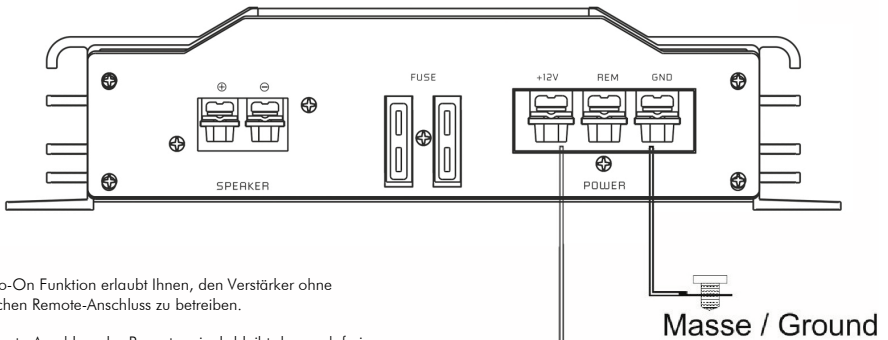
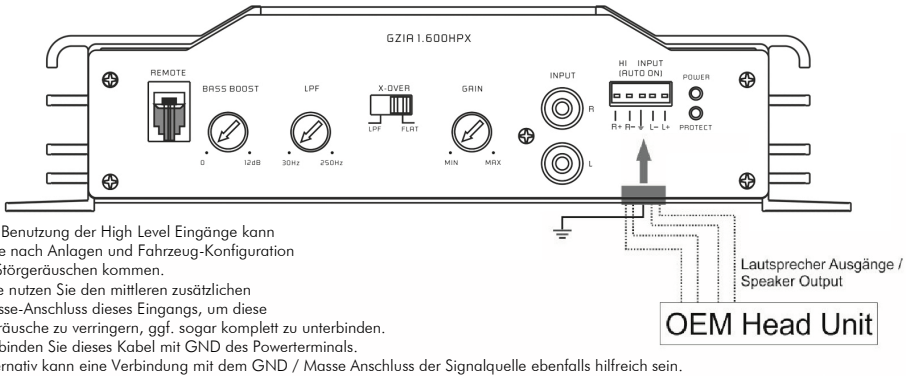

High Level Input – GZIA 2080HPX-B

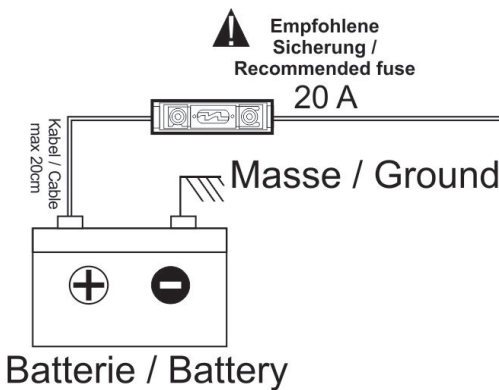
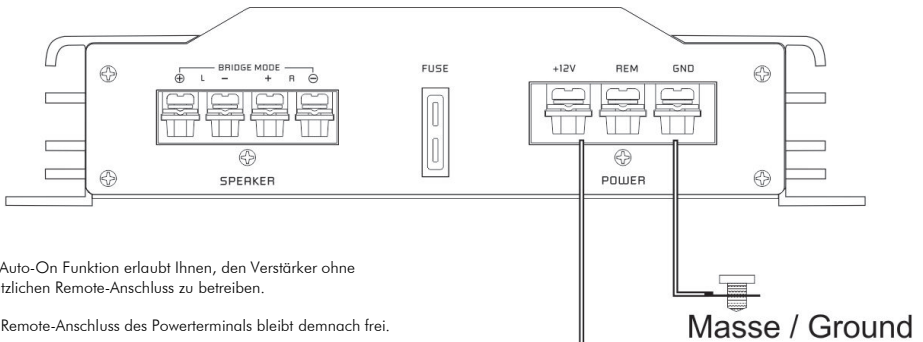
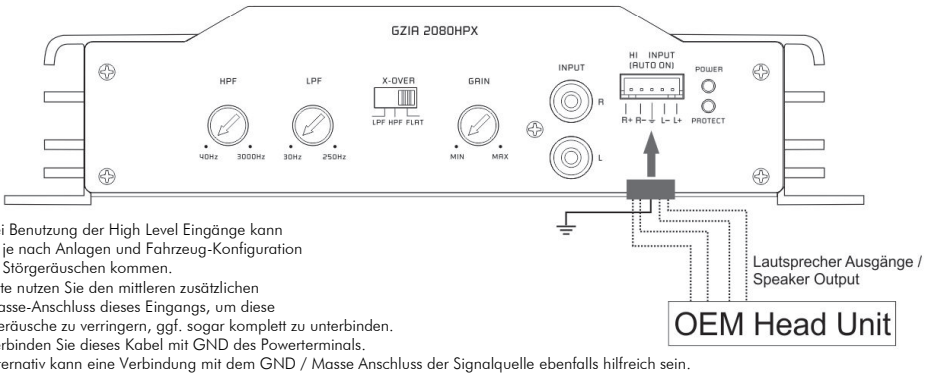

High Level Input – GZIA 2130HPX-B

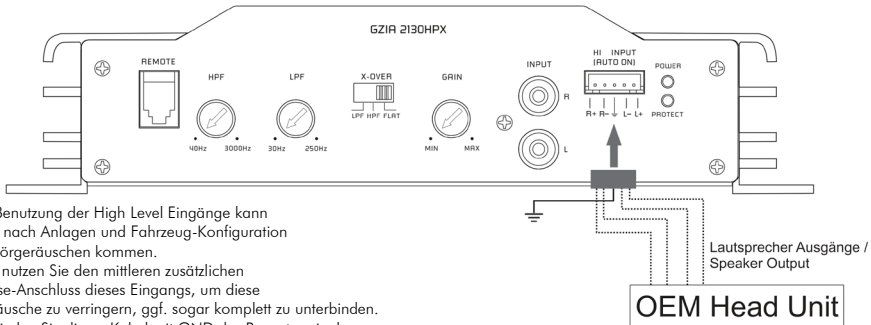

Bei Benutzung der High Level Eingänge kann es je nach Anlagen und Fahrzeug-Konfiguration zu Störgeräuschen kommen.

Bitte nutzen Sie den mittleren zusätzlichen Masse-Anschluss dieses Eingangs, um diese Geräusche zu verringern, ggf. sogar komplett zu unterbinden. Verbinden Sie dieses Kabel mit GND des Powerterminals.

Alternativ kann eine Verbindung mit dem GND / Masse Anschluss der Signalquelle ebenfalls hilfreich sein.

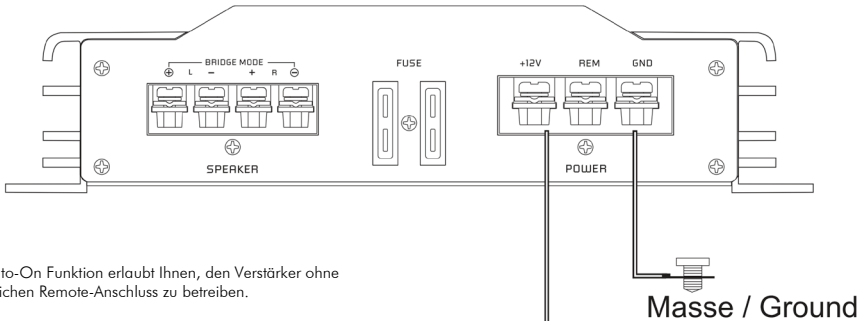

Die Auto-On Funktion erlaubt Ihnen, den Verstärker ohne zusätzlichen Remote-Anschluss zu betreiben.

Der Remote-Anschluss des Powerterminals bleibt demnach frei.

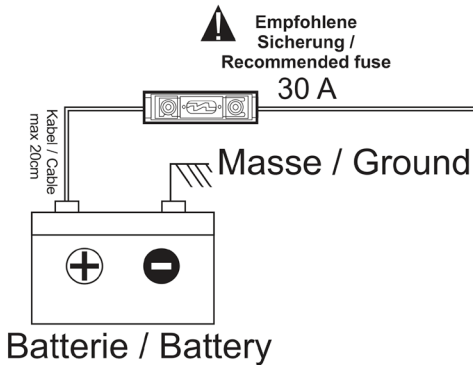

High Level Input – GZIA 2235HPX-B

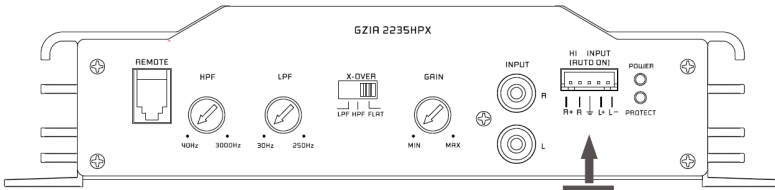

Bei Benutzung der High Level Eingänge kann es je nach Anlagen und Fahrzeug-Konfiguration zu Störgeräuschen kommen.

Bitte nutzen Sie den mittleren zusätzlichen Masse-Anschluss dieses Eingangs, um diese Geräusche zu verringern, ggf. sogar komplett zu unterbinden. Verbinden Sie dieses Kabel mit GND des Powerterminals.

Alternativ kann eine Verbindung mit dem GND / Masse Anschluss der Signalquelle ebenfalls hilfreich sein.

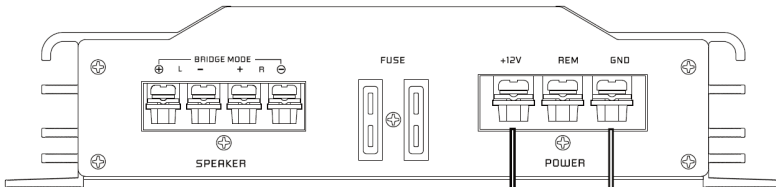

Die Auto-On Funktion erlaubt Ihnen, den Verstärker ohne zusätzlichen Remote-Anschluss zu betreiben.

Der Remote-Anschluss des Powerterminals bleibt demnach frei.

Masse / Ground

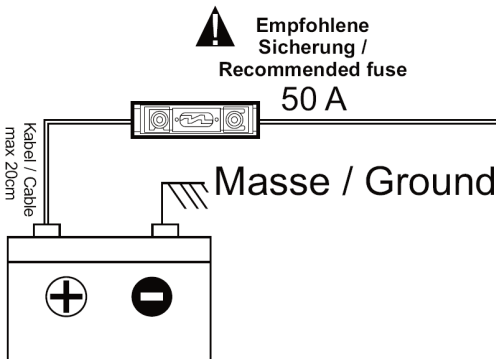

High Level Input – GZIA 4115HPX-B

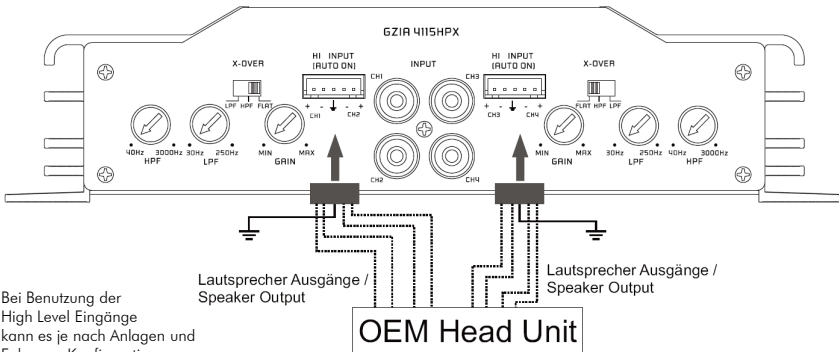

Bei Benutzung der High Level Eingänge kann es je nach Anlagen und Fahrzeug-Konfiguration zu

Störgeräuschen kommen. Bitte nutzen Sie den mittleren zusätzlichen Masse-Anschluss dieses Eingangs, um diese Geräusche zu verringern, ggf. sogar komplett zu unterbinden. Verbinden Sie dieses Kabel mit GND des Powerterminals. Alternativ kann eine Verbindung mit dem GND / Masse Anschluss der Signalquelle ebenfalls hilfreich sein.

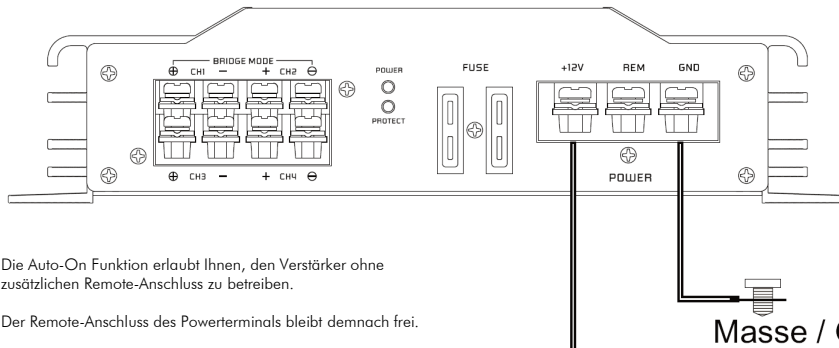

Die Auto-On Funktion erlaubt Ihnen, den Verstärker ohne zusätzlichen Remote-Anschluss zu betreiben.

Der Remote-Anschluss des Powerterminals bleibt demnach frei.

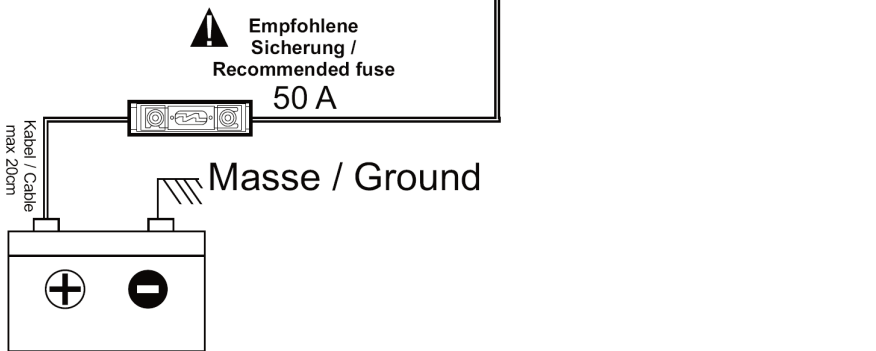

Einschalten des Verstärkers

Der Verstärker schaltet sich automatisch einige Sekunden nach dem Einschalten des Radios ein.

Achtung: Ihr Verstärker schaltet sich zeitweise aus, wenn er überhitzt ist, schaltet sich jedoch nach der Abkühlung automatisch wieder ein (ca. 80° C).

Einstellung des Audiopegels

1. LEVEL (MIN/MAX): mit Linksdrehung ganz auf MIN drehen
2. Drehen Sie die Lautstärke am Radio auf ungefähr 1/3 der Höchstlautstärke
3. Stellen Sie am LEVEL- Regler eine angenehme Lautstärke ein

Lautsprecher Anschluss für Trimode Betrieb – Bemerkungen

Der Trimodebetrieb ermöglicht es, einen Subwoofer Mono zu betreiben, während die Hauptlautsprecher in Stereobetrieb laufen. Bitte den Weichenschalter auf „Full“ – Stellung belassen.

Benutzen Sie 100 V bipolare Kondensatoren für die Hochpassweichen, um tiefe Frequenzen wegzufiltern und Luft- oder Kernspulen mit einem Drahtdurchmesser von mind. 1 mm für die Lowpassweiche, um die hohen Frequenzen zu blockieren.

Die Kondensator- und Spulenwerte können Sie den der unten stehenden Tabelle entnehmen, die Front- und Rearkanäle des Verstärkers nehmen diese Werte an. In den folgenden Bildern werden nur die hinteren linken und rechten Kanäle gezeigt.

Werte für 6dB Passivweiche

Frequenz	Spule	Kondensator
80 Hz	7,5 mH	470 uF
100 Hz	6,5 mH	330 uF
120 Hz	5,5 mH	370 uF
150 Hz	4 mH	220 uF

Anschluss – GZ1A 1.300HPX-B

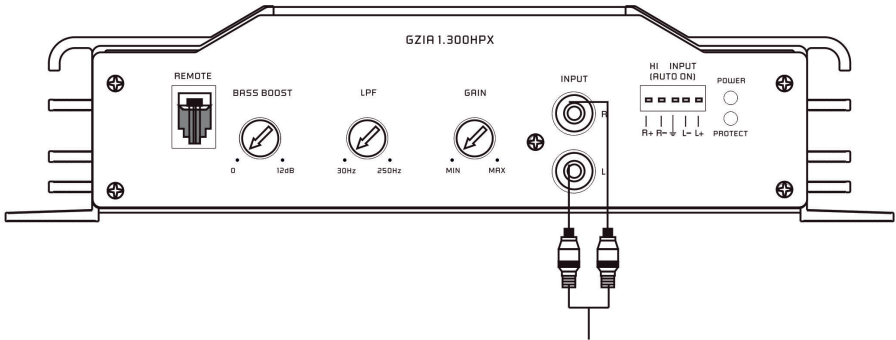

Zum Line out des Autoradios /
To car stereo line out /
Sortie stéréo de la voiture /
Naar line out radio

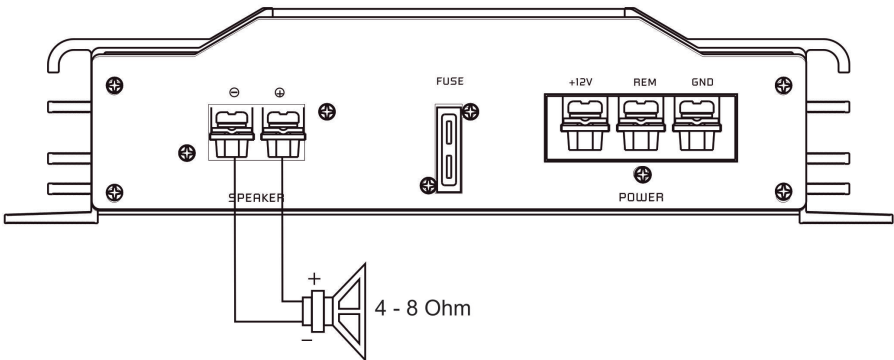

**Lautsprecher Impedanz /
Speaker impedance / Impédance haut parleur
4~8 Ohm**

Anschluss – GZ1A 1.600HPX-B

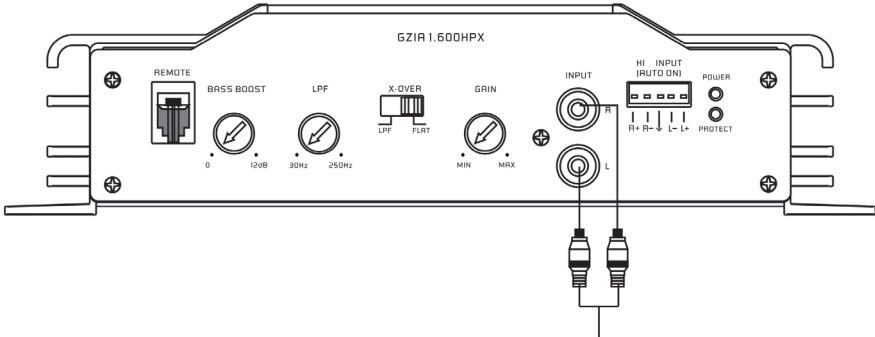

Zum Line out des Autoradios /
To car stereo line out /
Sortie stéréo de la voiture /
Naar line out radio

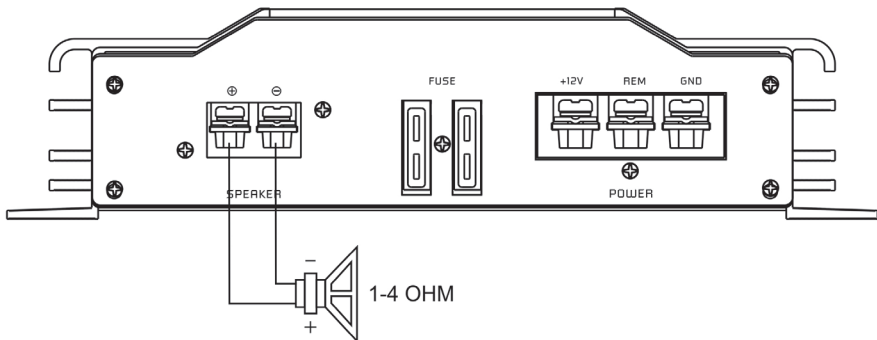

**Lautsprecher Impedanz /
Speaker impedance / Impédance haut parleur
1~4 Ohm**

Stereo Anschluss – GZIA 2080HPX-B

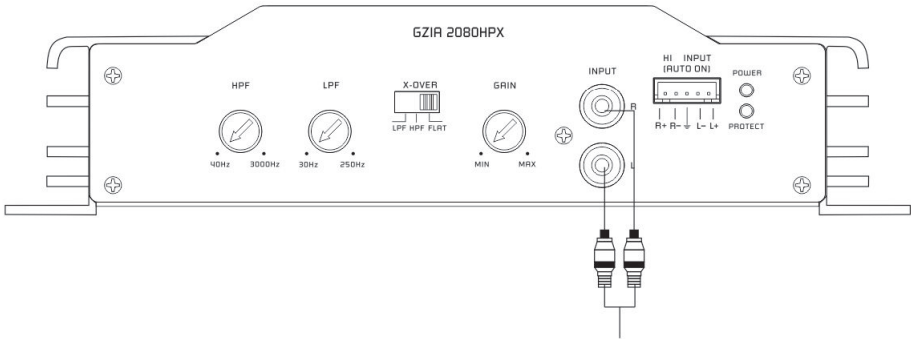

Zum Line out des Autoradios /
To car stereo line out / Sortie stéréo de la voiture /
Naar line out radio

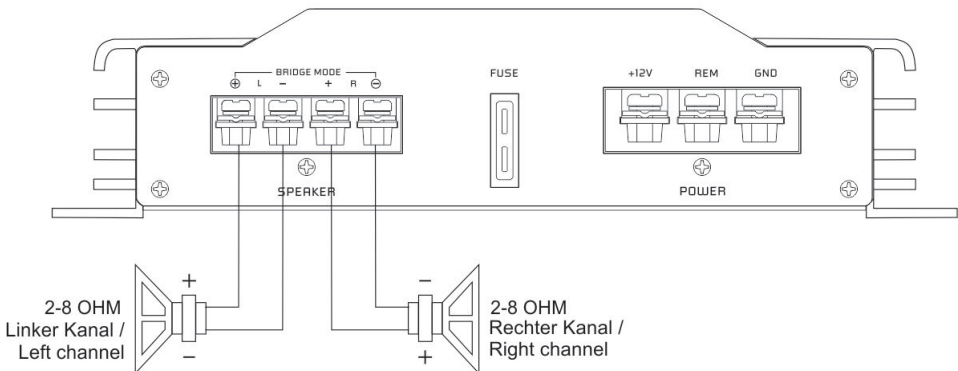

Lautsprecher Impedanz /
Speaker impedance / Impédance haut parleur
2 ~ 8 Ohm

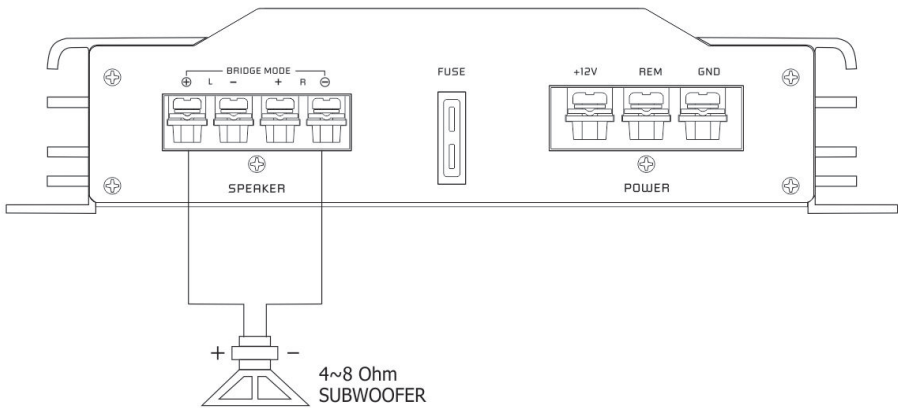

**Lautsprecher Impedanz /
Speaker impedance / Impédance haut parleur
4 ~ 8 Ohm**

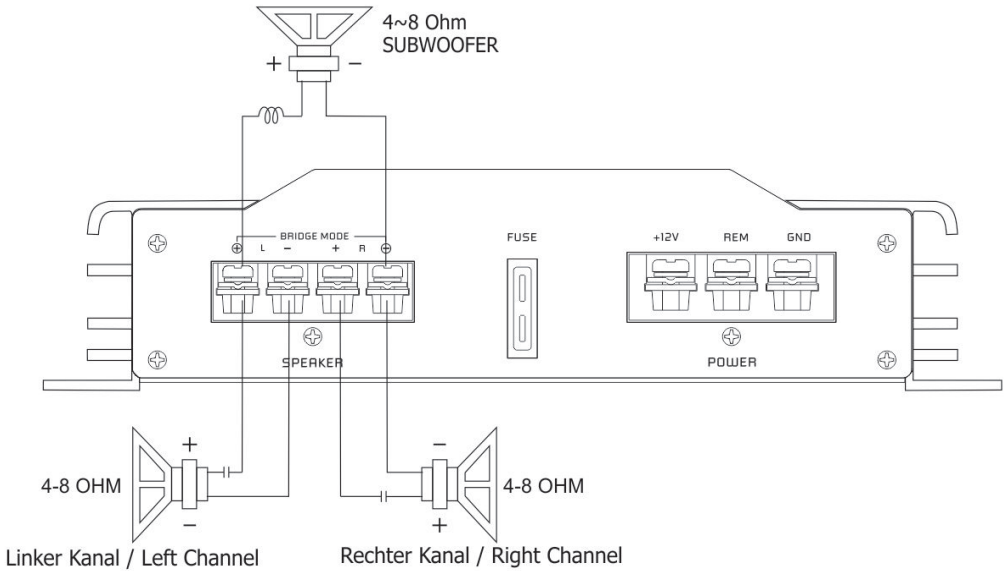

—||— Spule / Inductor / Filtre Pass bas / Spoel Lowpass Filter

—|— Kondensator / Capacitor / Condensateur / Condensator Highpass Filter

Lautsprecher Impedanz / Speaker impedance / Impédance haut parleur 4 ~ 8 Ohm

Stereo Anschluss – GZIA 2130HPX-B

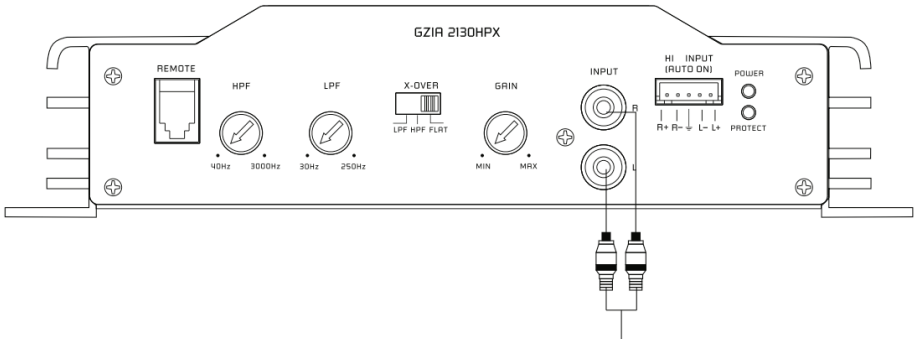

Zum Line out des Autoradios /
To car stereo line out / Sortie stéréo de la voiture /
Naar line out radio

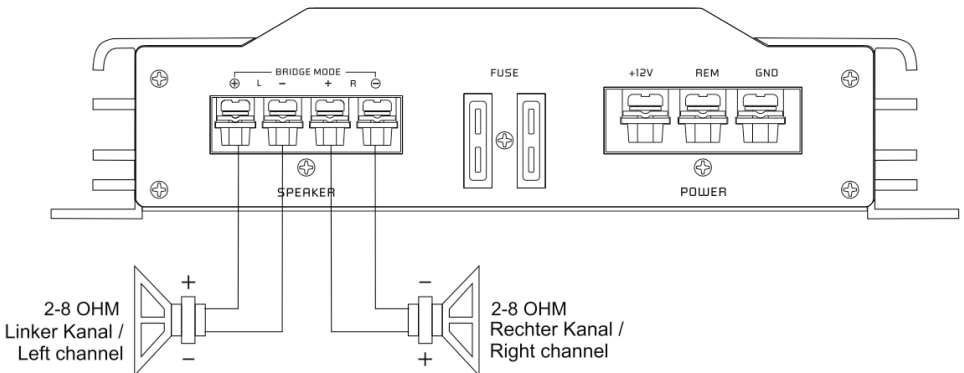

**Lautsprecher Impedanz /
Speaker impedance / Impédance haut parleur
2 ~ 8 Ohm**

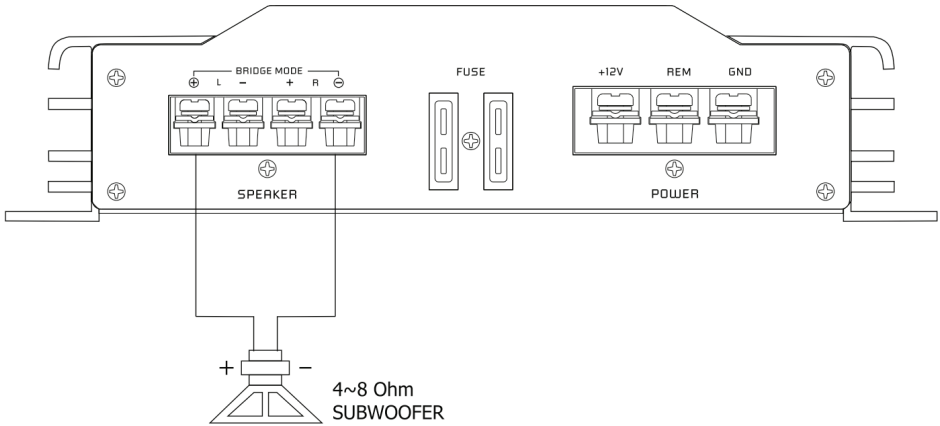

**Lautsprecher Impedanz /
Speaker impedance / Impédance haut parleur
4 ~ 8 Ohm**

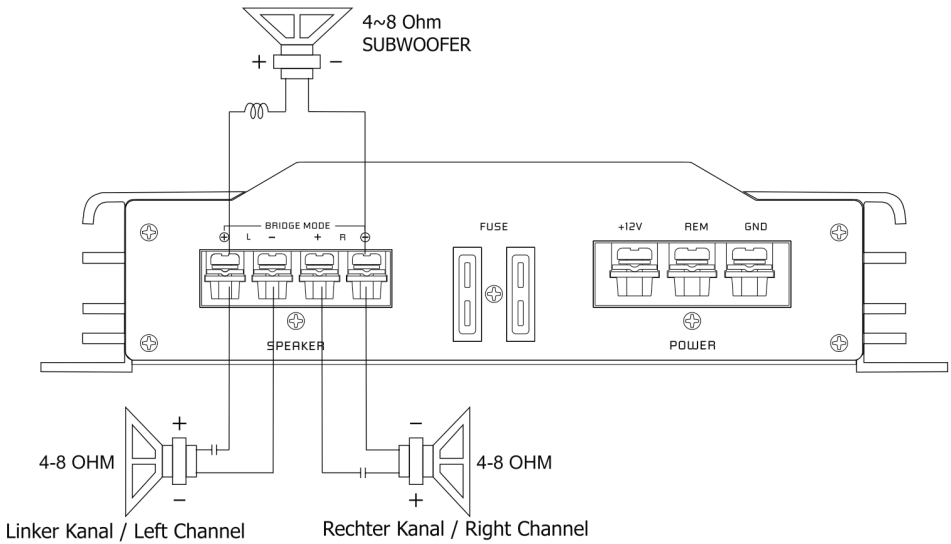

- ∞— Spule / Inductor / Filtre Pass bas / Spoel Lowpass Filter
- |— Kondensator / Capacitor / Condensateur / Condensator Highpass Filter

Lautsprecher Impedanz / Speaker impedance / Impédance haut parleur 4 ~ 8 Ohm

Stereo Anschluss – GZIA 2235HPX-B

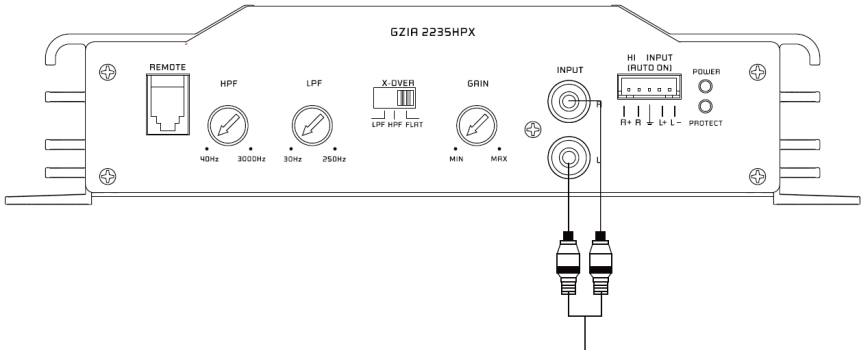

Zum Line out des Autoradios /
To car stereo line out / Sortie stéréo de la voiture /
Naar line out radio

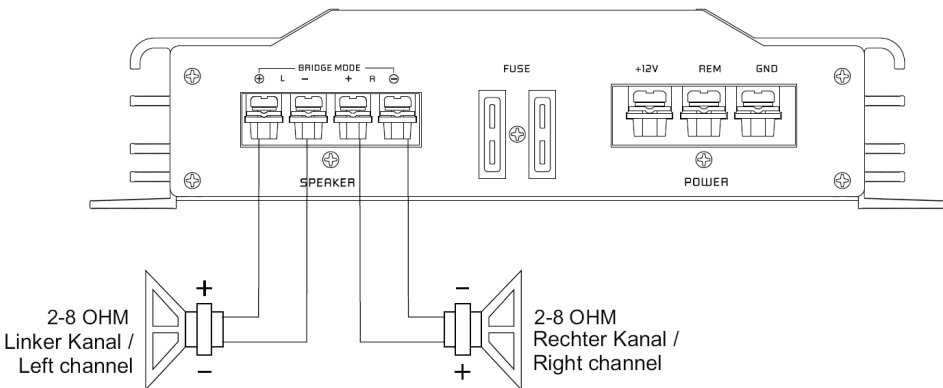

**Lautsprecher Impedanz /
Speaker impedance / Impédance haut parleur
2 ~ 8 Ohm**

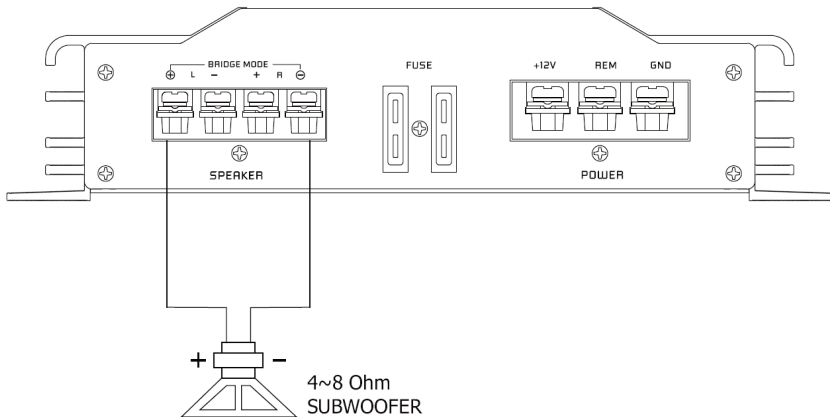

**Lautsprecher Impedanz /
Speaker impedance / Impédance haut parleur
4 ~ 8 Ohm**

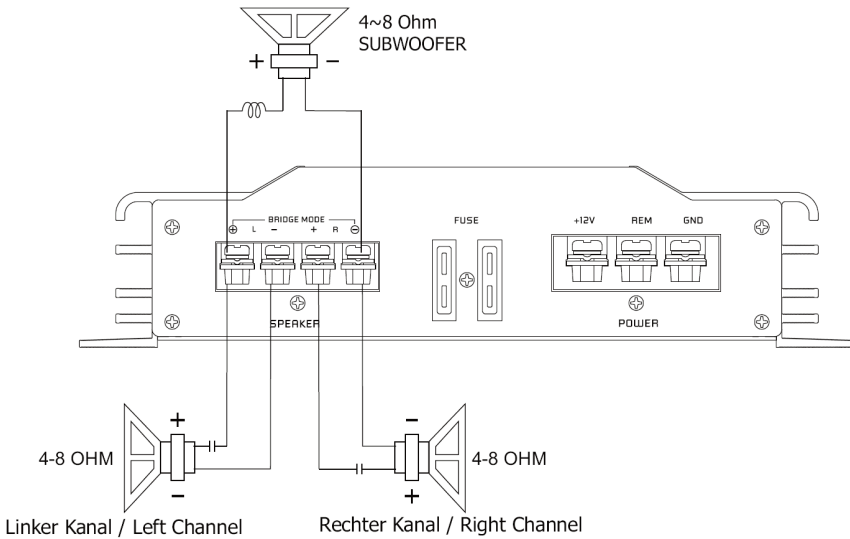

—○— Spule / Inductor / Filtre Pass bas / Spoel Lowpass Filter

—||— Kondensator / Capacitor / Condensateur / Condensator Highpass Filter

Lautsprecher Impedanz / Speaker impedance / Impédance haut parleur 4 ~ 8 Ohm

Stereo Anschluss – GZIA 4115HPX-B

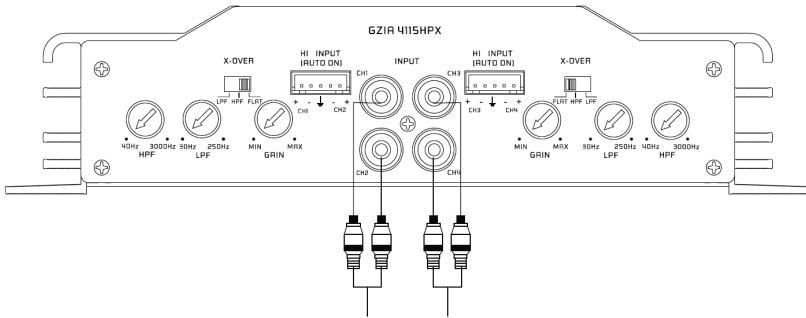

Zum Line out des Autoradios /
To car stereo line out / Sortie stéréo de la voiture /
Naar line out radio

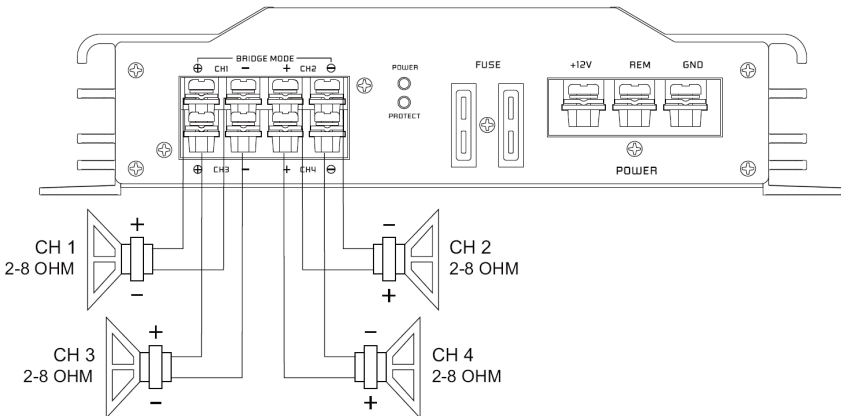

**Lautsprecher Impedanz /
Speaker impedance / Impédance haut parleur
2 ~ 8 Ohm**

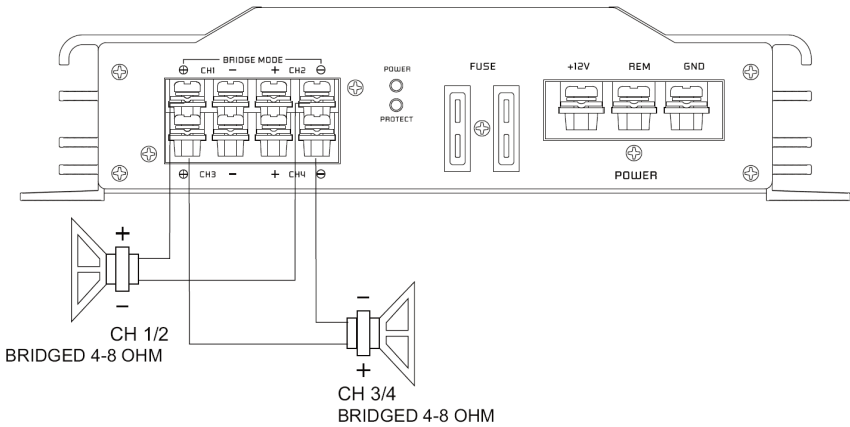

**Lautsprecher Impedanz /
Speaker impedance / Impédance haut parleur
4 ~ 8 Ohm**

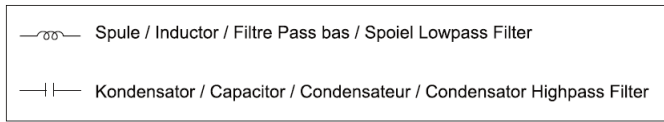
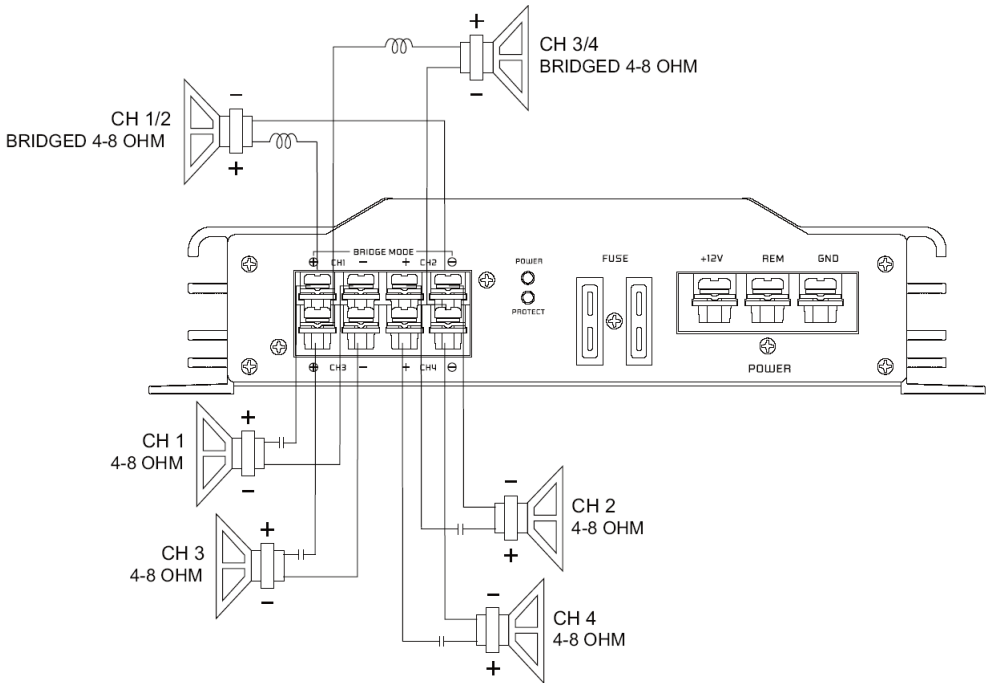

**Lautsprecher Impedanz /
Speaker impedance / Impédance haut parleur
4 ~ 8 Ohm**

Technische Daten

Model	GZIA 1.300HPX-B	GZIA 1.600HPX-B
Typ	1 Kanal Class A/B	1 Kanal Class A/B
RMS Power @ 4 Ω CEA Standard CEA-2006-A	1 x 200 W (1% THD+N)	1 x 230 W (1% THD+N)
RMS Power @ 2 Ω CEA Standard CEA-2006-A	-	1 x 400 W (1% THD+N)
RMS Power @ 1 Ω CEA Standard CEA-2006-A	-	1 x 600 W (1% THD+N)
MAX Power CEA Standard CEA-2006-A	1 x 300 W @ 4 Ω (10% THD+N)	1 x 700 W @ 1 Ω (10% THD+N)
Dämpfungsfaktor	> 150	> 150
Signal to noise Ratio	> 80 dB	> 80 dB
Tiefpass Weiche	30 – 250 Hz	30 – 250 Hz
Bass Boost	0 – 12 dB	0 – 12 dB
Hochpass Weiche	-	-
Frequenzgang	10 Hz – 250 Hz	10 Hz – 30 KHz
Eingangsempfindlichkeit	200 mV – 6 V	200 mV – 6 V
Bass-Pegelfernbedienung	✓	✓
Auto-On @ High Input	✓	✓
Sicherung	1 x 30A	2 x 30A
Abmessungen B x H x L mm	200 x 213 x 50	333 x 213 x 50
Abmessungen B x H x L inch	8.39" x 8.39" x 1.97"	13.11" x 8.39" x 1.97"

Technische Daten

Model	GZIA 2080HPX-B	GZIA 2130HPX-B	GZIA 2235HPX-B	GZIA 4115HPX-B
Typ	2 Kanal Class A/B	2 Kanal Class A/B	2 Kanal Class A/B	4 Kanal Class A/B
RMS Power @ 4 Ω CEA Standard CEA-2006-A	2 x 60 W (1% THD+N)	2 x 85 W (1% THD+N)	2 x 150 W (1% THD+N)	4 x 70 W (1% THD+N)
RMS Power @ 2 Ω CEA Standard CEA-2006-A	2 x 80 W (1% THD+N)	2 x 130 W (1% THD+N)	2 x 235 W (1% THD+N)	4 x 115 W (1% THD+N)
RMS Power @ 1 Ω CEA Standard CEA-2006-A	-	-	-	-
RMS Power @ 4Ω Gebrückt CEA Standard CEA-2006-A	1 x 200 W (1% THD+N) 1 x 240 W (10% THD+N)	1 x 260 W (1% THD+N) 1 x 320 W (10% THD+N)	1 x 470 W (1% THD+N) 1 x 540 W (10% THD+N)	2 x 230 W (1% THD+N) 2 x 250 W (10% THD+N)
Dämpfungsfaktor	> 150	> 150	> 100	> 100
Signal to noise Ratio	> 85 dB	> 85 dB	> 80 dB	> 80 dB
Tiefpass Weiche	30 – 250 Hz	30 – 250 Hz	30 – 250 Hz	30 – 250 Hz
Hochpass Weiche	40 – 3000 Hz	40 – 3000 Hz	40 – 3000 Hz	40 – 3000 Hz
Frequenzgang	10 Hz – 30 KHz	10 Hz – 30 KHz	10 Hz – 30 KHz	10 Hz – 30 KHz
Eingangsempfindlichkeit	200 mV – 6 V	200 mV – 6 V	200 mV – 6 V	200 mV – 6 V
Bass-Pegelfernbedienung	-	✓ (optional)	✓	-
Auto-On @ High Input	✓	✓	✓	✓
Sicherung	1 x 20A	2 x 15A	2 x 25A	2 x 25A
Abmessungen B x H x L mm	175 x 213 x 50	215 x 213 x 50	285 x 213 x 50	285 x 213 x 50
Abmessungen B x H x L inch	6.89" x 8.39" x 1.97"	8.46" x 8.39" x 1.97"	11.22" x 8.39" x 1.97"	11.22" x 8.39" x 1.97"

Wenn irgendetwas nicht funktioniert

Problem	Kontrolle	Hilfe
Kein Ton	Leuchtet die PWR LED?	Sicherung prüfen Remote Kabel prüfen + 12 Volt prüfen Masse prüfen
	Leuchtet die PROT LED?	Kurzschluss am Lautsprecher Gerät überhitzt Gerät defekt
Verstärker schaltet nicht ein	Keine Stromzufuhr	Sicherung prüfen + 12Volt prüfen Masse prüfen
	Keine Spannung am Remote	Remote am Radio prüfen
Verstärker schaltet bei Lautstärke ab	Lautsprecherimpedanz prüfen	Prüfen Sie, ob der minimal zulässige Widerstand am LS Terminal von nicht unterschritten wird
Ton fehlt an einem Kanal	Cinch / Lautsprecherkabel prüfen	Kabel/Stecker beschädigt

Die Gewährleistung entspricht der gesetzlichen Regelung. Eine Rücksendung kann nur nach vorheriger Absprache und in der Originalverpackung erfolgen. Bitte unbedingt einen maschinell erstellten Kaufbeleg und eine Fehlerbeschreibung beilegen. Von der Gewährleistung ausgeschlossen sind Defekte, die durch Überlastung, unsachgemäße Behandlung oder bei Teilnahme an Wettbewerben entstanden sind. Wir behalten uns das Recht vor, zukünftig nötige Änderungen oder Verbesserungen an dem Produkt vorzunehmen ohne den Kunden darüber zu informieren.

Limited warranty - defective products must be returned in original packaging - please add a copy of the original purchasing invoice showing the purchasing date and a detailed description of the failure. Failure caused by overload, misuse or by using the product for competition purpose are not covered by the warranty. We reserve the right to make needed change or improvement to the product without informing customer about this in advance.

De Garantie bepalingen van alle door ground zero geleverde producten is volgens wettelijke bepalingen geregeld. Een retourzending kan alleen na duidelijke afspraak en in de originele verpakking plaatsvinden. SVP een aankoopbon en een duidelijke storingsomschrijving bijvoegen. Van garantie uitgesloten zijn defecten door overbelasting, onkundig gebruik, of door deelname aan wedstrijden (SPL) ontstaan zijn. Wij behouden ons het recht om de nodige veranderingen of verbeteringen aan het product door te voeren zonder de klant hierover te informeren.

La garantie est conforme aux droits légaux. Un retour du produit défectueux doit être dans son emballage d'origine sur présentation du reçu ou de la facture indiquant la description du défaut. La présente Garantie n'est pas applicable lorsque le produit a été endommagé en raison: Mauvaise alimentation, Trop de puissance (HP, Subwoofer) Accident, Installation ou Utilisation non conforme aux normes Technique (Concours SPL etc). Nous nous réservons le droit d'entreprendre à l'avenir nécessairement des modifications ou des améliorations au produit sans informer le client.

Ground Zero GmbH

Erlenweg 25, 85658 Egming, Germany

Tel. +49 (0)8095/873 830 Fax -8310

www.ground-zero-audio.com



GROUND ZERO[®]

GERMAN ENGINEERING

IRIDIUM-SERIES AMPLIFIER

OWNER'S MANUAL

GZIA 1.300HPX-B

GZIA 1.600HPX-B

GZIA 2080HPX-B

GZIA 2130HPX-B

GZIA 2235HPX-B

GZIA 4115HPX-B

Features

- 4 Ohm / 2 Ohm stable Stereo
- 4 Ohm stable Mono (GZIA 1.300HPX-B)
- 1 Ohm stable Mono (GZIA 1.600HPX-B)
- Power & Protection indicator
- Bass Boost (GZIA 1.300HPX-B / 1.600HPX-B)
- Variable highpass (GZIA 2080HPX-B / 2235HPX-B / 2130HPX-B / 4115HPX-B)
- Variable lowpass
- Auto-On @ High Level Input
- Adjustable input sensitivity
- Soft delayed remote turn- on
- Bass remote (GZIA 1.300HPX-B / 1.600HPX-B / 2235HPX-B, GZIA 2130HPX-B optional)
- Thermal / Short / Overload protection

Tools and materials you need

- Screwdriver
- Electric drill, 3 mm / 0.12" carbide drill bit
- Mounting screws
- Power wire min. 10 mm² / 7 AWG
- Ground wire min. 10 mm² / 7 AWG
- Speaker wire min. 2 x 1,5 mm² / 15 AWG

Please note!

- As a precaution it is advisable to disconnect the vehicle's battery before making connection to the +12 Volts supply wiring (see owner's manual of your car for further information).
- Please use great caution drilling your trunk. Your gas tank and brake lines can be damaged by puncturing with your drill bit – this could cause damage or failure of your car's operating systems.
- Never pass wires over sharp angles. It is recommended to buffer the power supply of the amplifier with a capacitor min. 1 Farad to guarantee a stable operation voltage.

WARNING !

High powered audio systems in a vehicle are capable of generating "Live Concert" levels of sound pressure. Continued exposure to excessively high volume sound levels may cause hearing loss or damage. Also, operation of a motor vehicle while listening to audio equipment at high volume levels may impair your ability to hear external sounds such as; horns, warning signals, or emergency vehicles, thus constituting a potential traffic hazard. In the interest of safety, Consumer Electronics recommends listening at lower volume levels while driving.

Planning your system

Before beginning the installation, consider the following:

- a. If you plan to expand your system by adding other components sometime in the future, ensure adequate space is left, and cooling requirements are met.
- b. If your radio / source is equipped with pre-amp outputs, it is possible to utilize them to drive the amplifier

Mounting your amplifier

- a. Select a suitable location that is convenient for mounting, is accessible for wiring and has ample room for air circulation and cooling.
- b. Use the amplifier as a template to mark the mounting holes, remove the amplifier.

Warning

Choose a mounting position where all eclectic wires are protected from being damaged by sharp edges, heat or other conditions. +12Volt DC electrical connections must be fused on the battery side. Make sure your radio and all other devices will be turned off while connection your system.

If you need to replace the power fuse, replace it only with a fuse identical to that supplied with the system. Using a fuse of different type or rating may result in damage to this system which isn't covered by the warranty.

Controls and functions – GZIA 1.300HPX-B

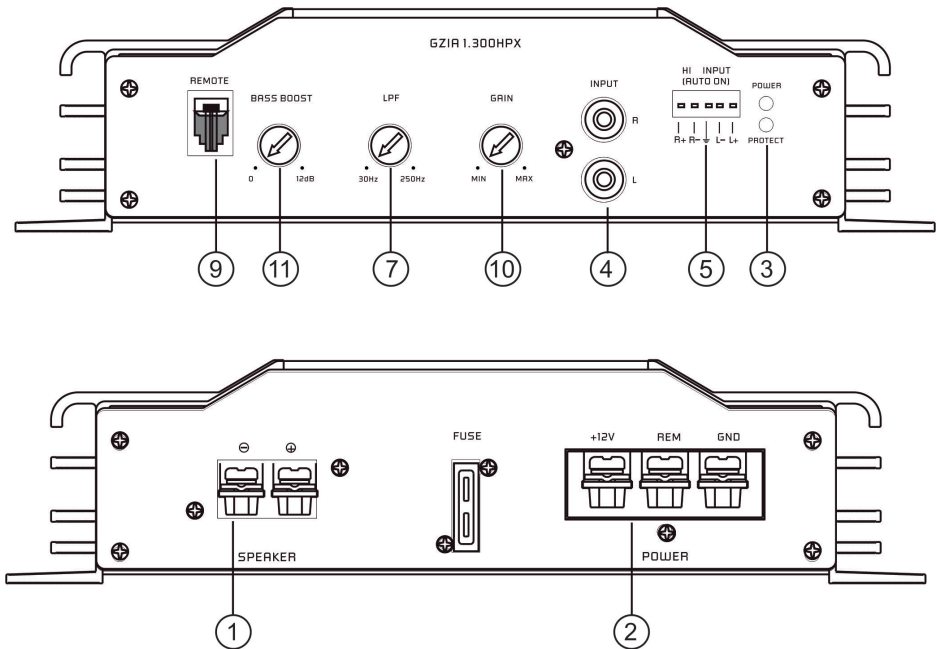

Controls and functions – GZIA 1.600HPX-B

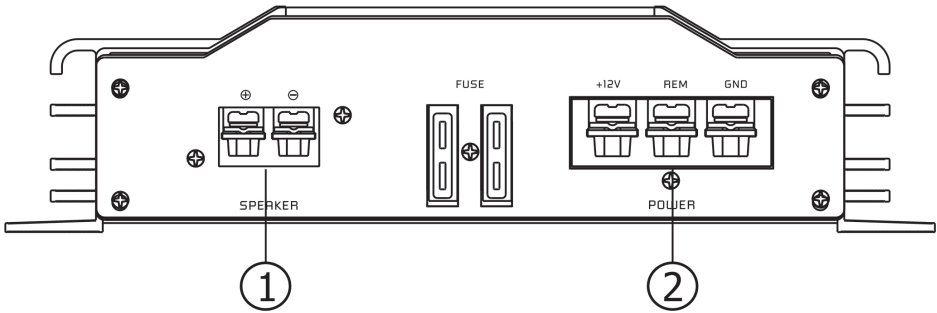
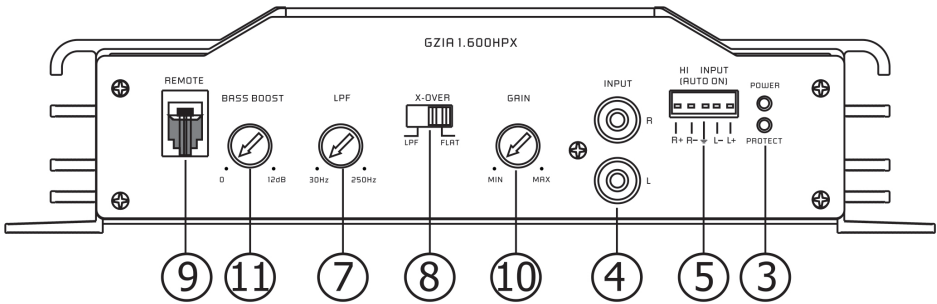

Controls and functions – GZIA 2080HPX-B

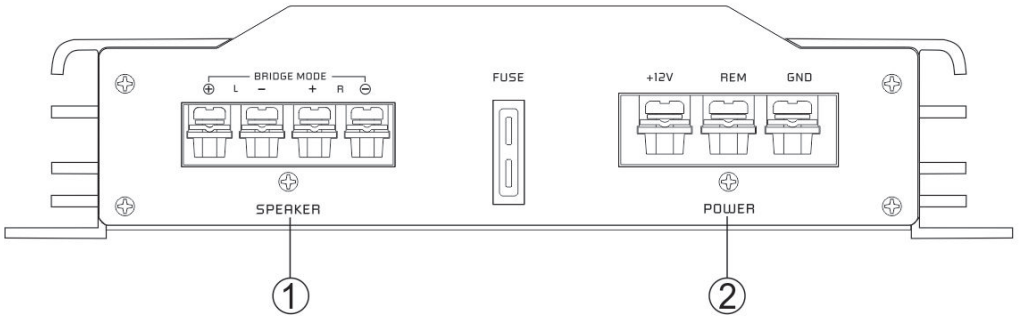
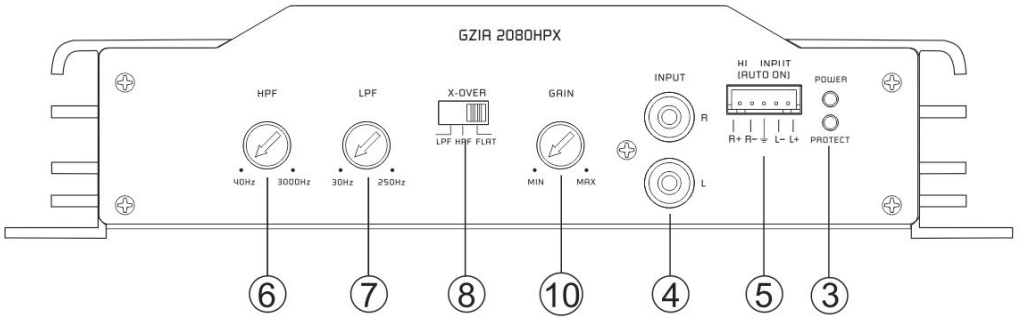

Controls and functions – GZIA 2130HPX-B

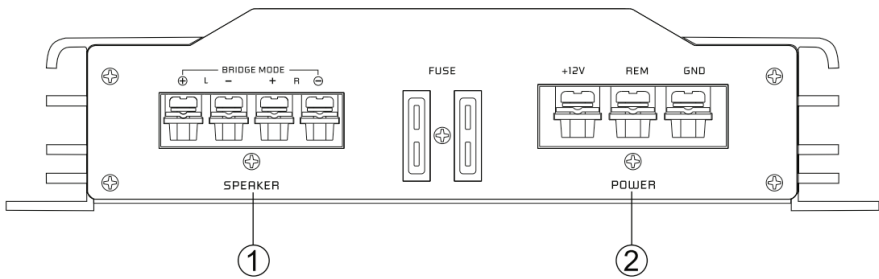
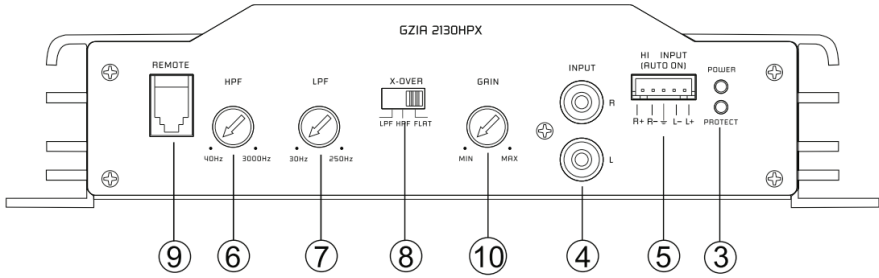

Controls and functions – GZ1A 2235HPX-B

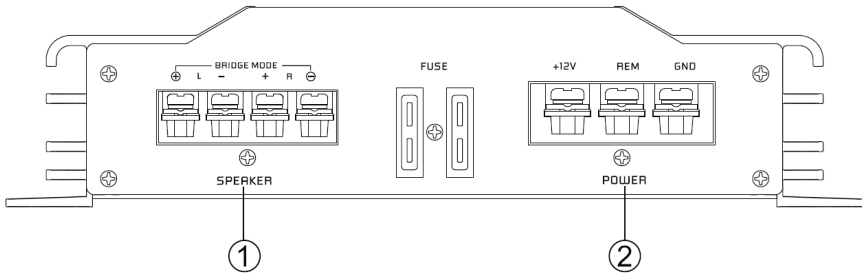
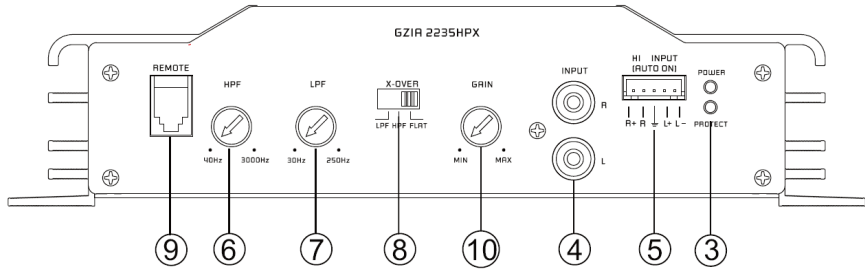

Controls and functions – GZIA 4115HPX-B

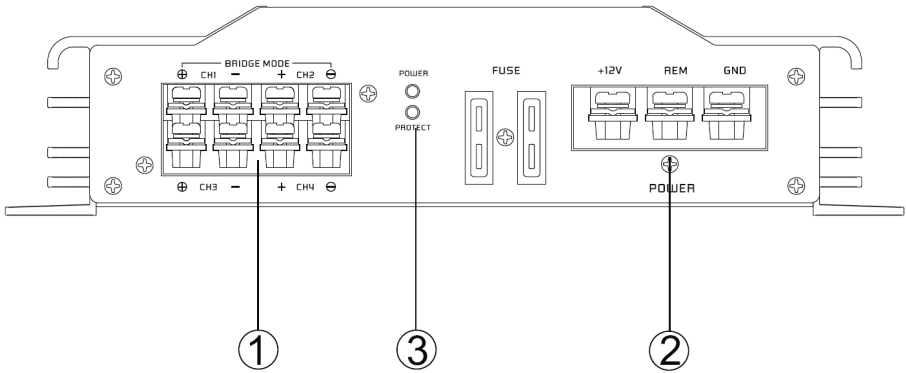
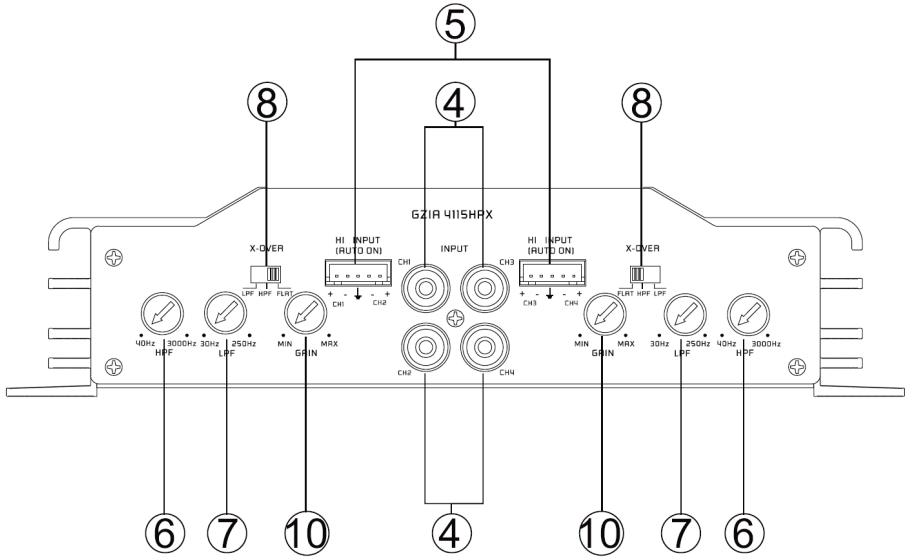

Controls and functions

1	Speaker terminals	For connection of the speakers GND -> Ground connection
2	Power terminals	REM -> Remote antenna terminal [Not for use with High level inputs (5)] BATT -> +12 Volt
3	Status indication	GREEN – OK RED – Error
4	Cinch inputs	Terminal for connection of the RCA wires. To avoid failure, please use high quality RCA wires. IMPORTANT! Do not use the High level inputs and the Cinch inputs parallel, this can damage the amplifier. Use either the Cinch OR the High Level inputs.
5	High Level inputs	These inputs must be used if your head unit is not equipped with a Low Level Cinch output. Connect this input to the speaker outputs of your head unit. The amplifier automatically turns on as soon as a signal is received (Auto On). The remote connection of the Power- Terminal (2) won't be used. IMPORTANT! Do not use the High level inputs and the Cinch inputs parallel, this can damage the amplifier. Use either the Cinch OR the High Level inputs.
6	High Pass controller	Set the filter switch to „HIGH“ position. Adjust the variable HPF crossover frequency to the desired frequency using the controller. All frequency between 40 and 3000 Hz will be reproduced.
7	Low Pass controller	Only frequencies from 30Hz to 250Hz will be reproduced (depending on the LPF filter controller position). Set the filter switch to „LOW“ position. Adjust the variable LPF frequency to the desired frequency using the controller.
8	Mode switch	Adjust the crossover for the chosen utilization. LPF – Only bass frequencies (below 30Hz - 250Hz) will be reproduced. FLAT – All frequencies will be reproduced. HPF – Only middle and high frequencies (over 40Hz – 3000Hz) will be reproduced.
9	Remote control input	For connection of bass remote control (GZIA 2130HPX/2235HPX/1.600HPX)
10	Input level controller	With this controller you can adjust the input sensitivity.
11	Bass Boost controller	For adjusting a Bass Boost at 45 Hz from 0 – 12 dB

High Level Input

Depending on the configuration of your car and sound system, error noises may appear when using the high level inputs. Please use the additional middle ground-connection of this input to reduce these noises.

The Auto-On function allows you to use the amplifier without an additional remote connection. This makes it possible to operate it with an OEM headunit and OEM active systems, which are not equipped with cinch outputs or switched remote-outputs.

High Level Input – GZIA 1.300HPX-B

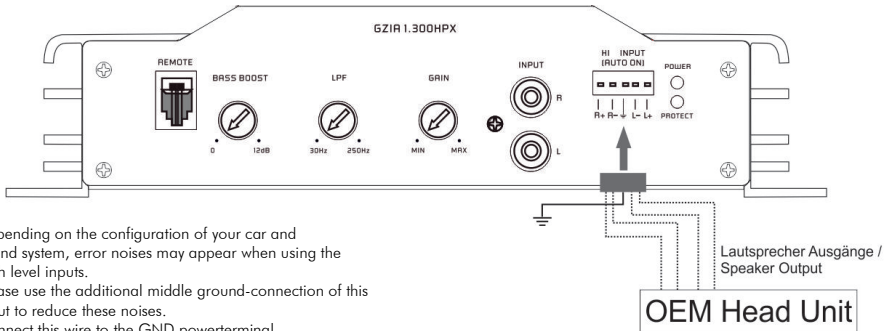

Depending on the configuration of your car and sound system, error noises may appear when using the high level inputs. Please use the additional middle ground-connection of this input to reduce these noises. Connect this wire to the GND powerterminal. A connection to the GND connection of the signal source can also be useful.

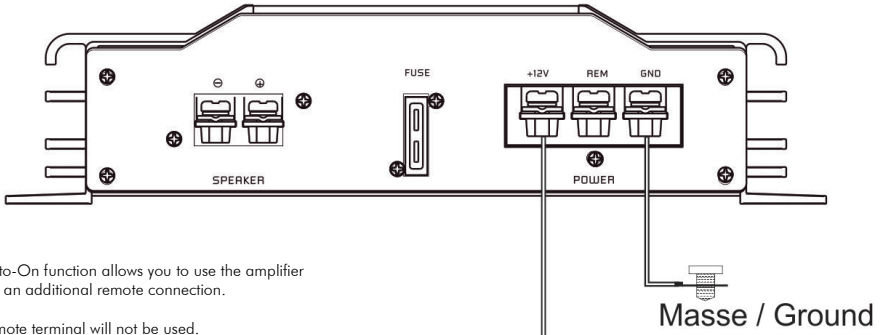

The Auto-On function allows you to use the amplifier without an additional remote connection.

The remote terminal will not be used.

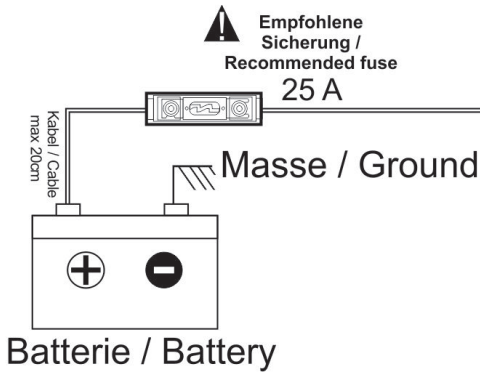

High Level Input – GZIA 1.600HPX-B

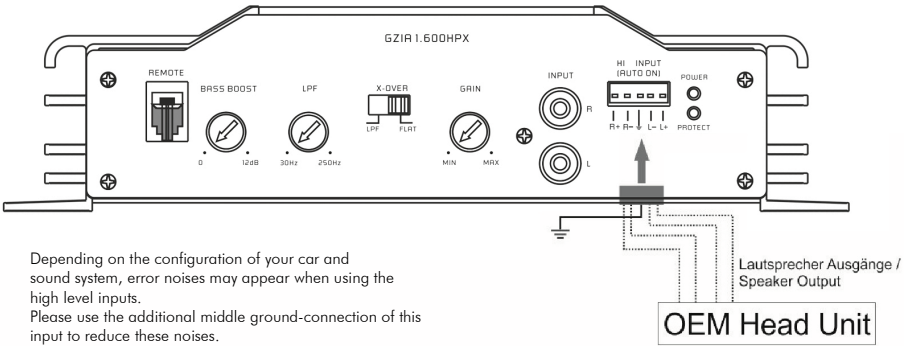

Depending on the configuration of your car and sound system, error noises may appear when using the high level inputs.
Please use the additional middle ground-connection of this input to reduce these noises.
Connect this wire to the GND powerterminal.
A connection to the GND connection of the signal source can also be useful.

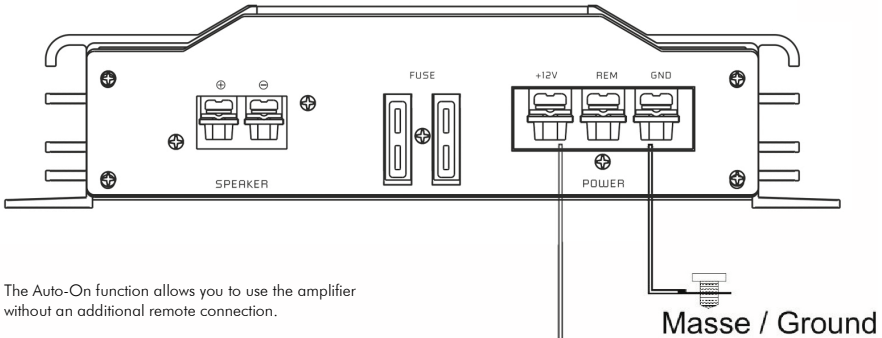

The Auto-On function allows you to use the amplifier without an additional remote connection.

The remote terminal will not be used.

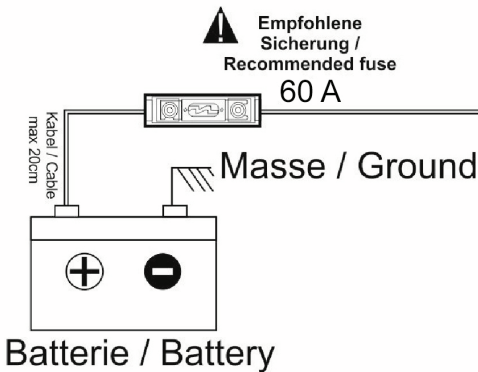

High Level Input – GZIA 2080HPX-B

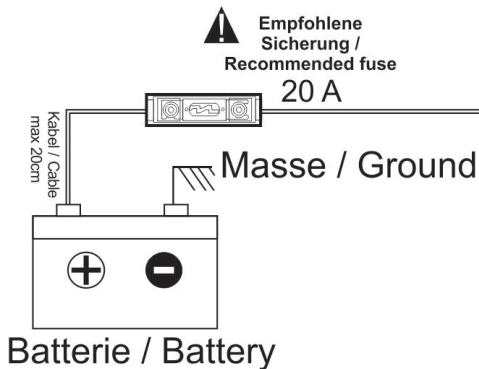
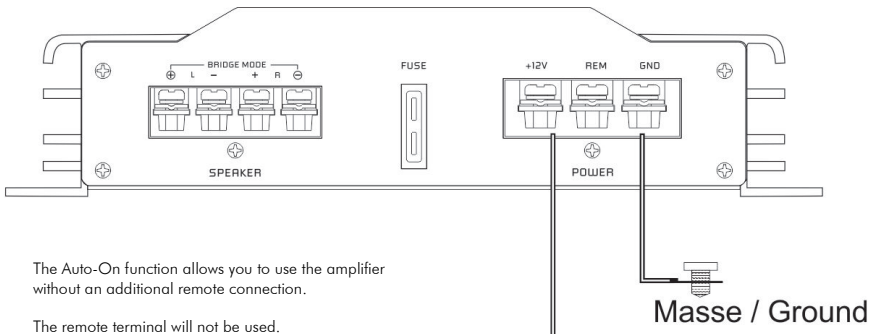
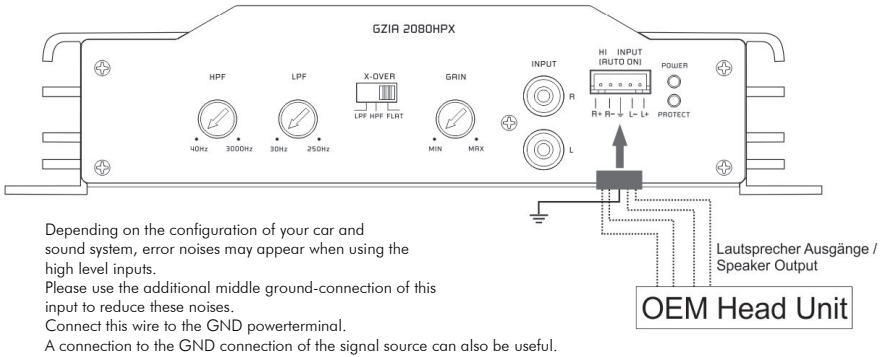

High Level Input – GZIA 2130HPX-B

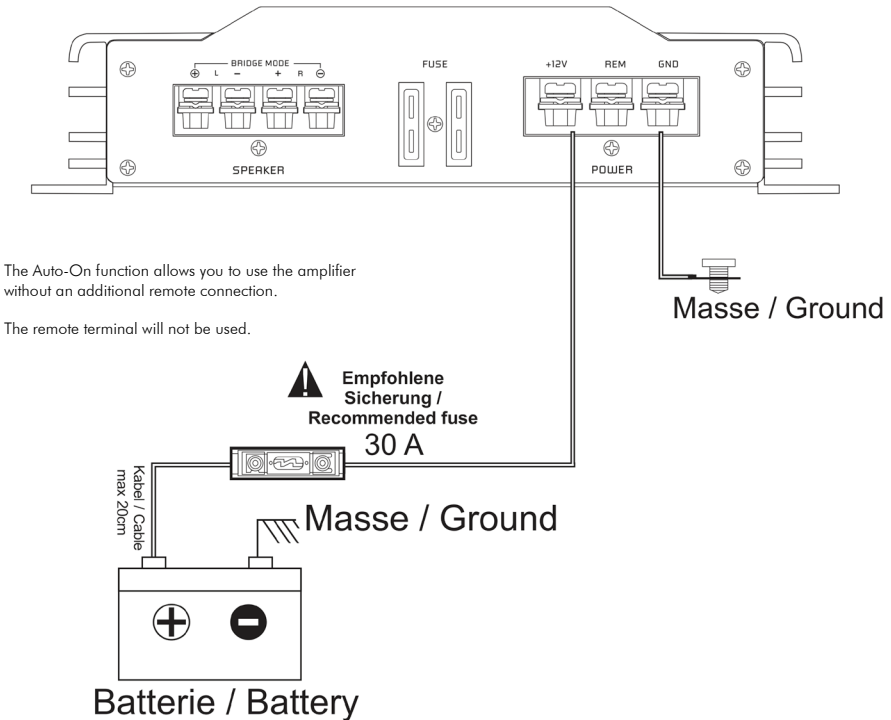
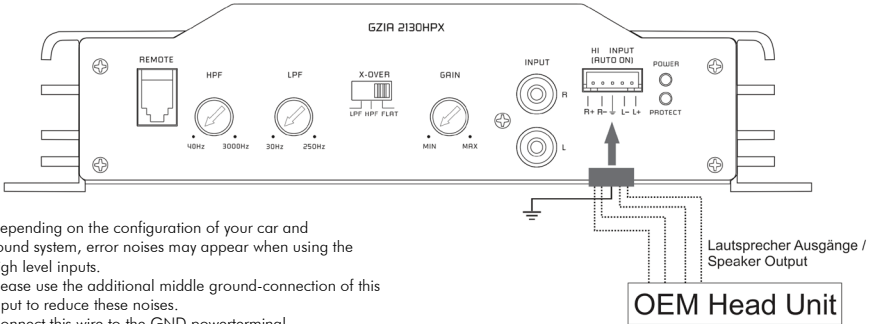

High Level Input – GZIA 2235HPX-B

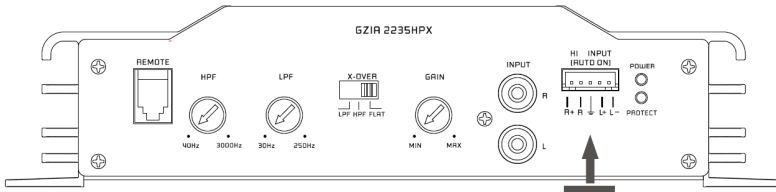

Depending on the configuration of your car and sound system, error noises may appear when using the high level inputs. Please use the additional middle ground-connection of this input to reduce these noises. Connect this wire to the GND powerterminal. A connection to the GND connection of the signal source can also be useful.

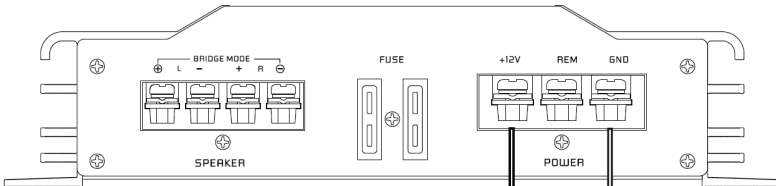

The Auto-On function allows you to use the amplifier without an additional remote connection.

The remote terminal will not be used.

Masse / Ground

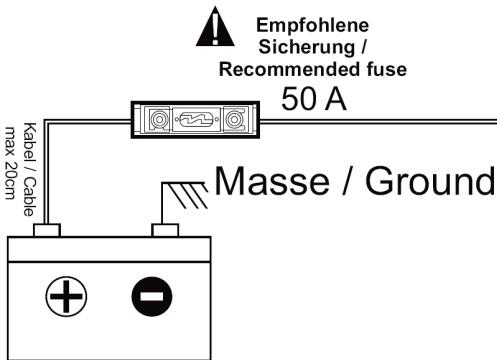

High Level Input – GZIA 4115HPX-B

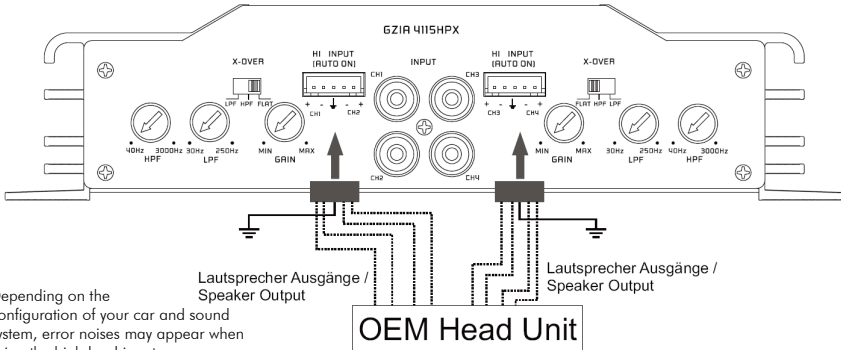

Depending on the configuration of your car and sound system, error noises may appear when using the high level inputs.

Please use the additional middle ground-connection of this input to reduce these noises. Connect this wire to the GND powerterminal.

A connection to the GND connection of the signal source can also be useful.

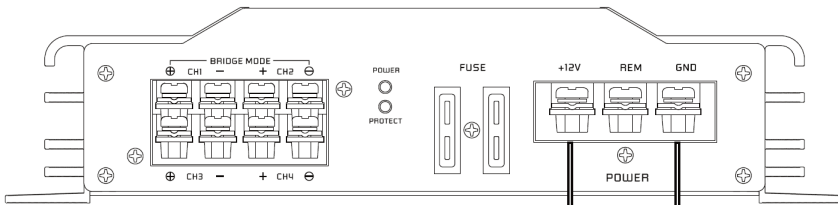

The Auto-On function allows you to use the amplifier without an additional remote connection.

The remote terminal will not be used.

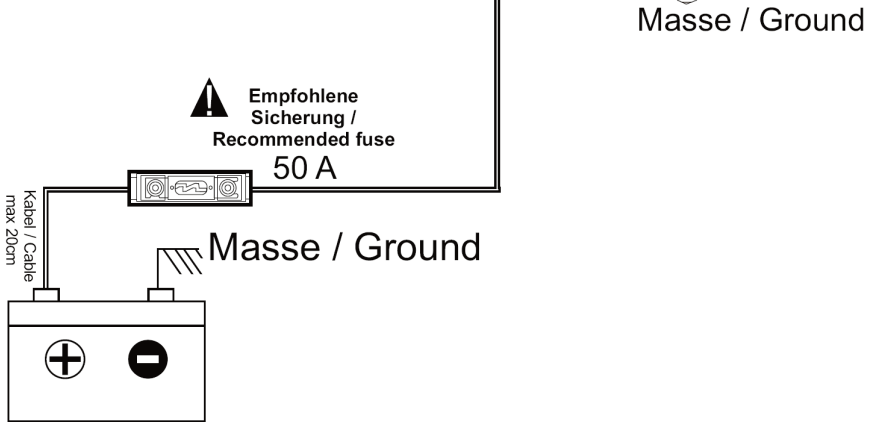

Turning on the amplifier

The amplifier automatically turns on a few seconds after you turn on your radio.

Note: Your amplifier temporarily shuts down if it gets too hot, then restarts automatically once it cools (At about 80° / 176° F).

Adjusting the audio level

1. LEVEL (Min/Max): Turn fully counter-clockwise to MIN position
2. Turn the auto sound system's volume control to about two-third of its full range.
3. Adjust LEVEL to a comfortable listening level.

Connecting the speaker for trimode operation - notes

TRI MODE operation output allows a subwoofer to be operated in mono mode while the main speakers are playing in stereo. Leave the crossover switch on "Full" position.

Use 100 volt, non-polar capacitors for a high pass crossover to filter out low frequencies and Air-core or Ferrite-core coils with a minimum diameter of 1 mm / 0.039" for the lowpass crossover to filter out high frequencies.

The capacitor and inductor values as written in the below table. The front and rear channels of this amplifier get this capability. Only the rear left and right channels are shown on the following pictures.

Values for 6dB passive crossover

Frequency	Inductor	Capacitor
80 Hz	7,5 mH	470 μ F
100 Hz	6,5 mH	330 μ F
120 Hz	5,5 mH	370 μ F
150 Hz	4 mH	220 μ F

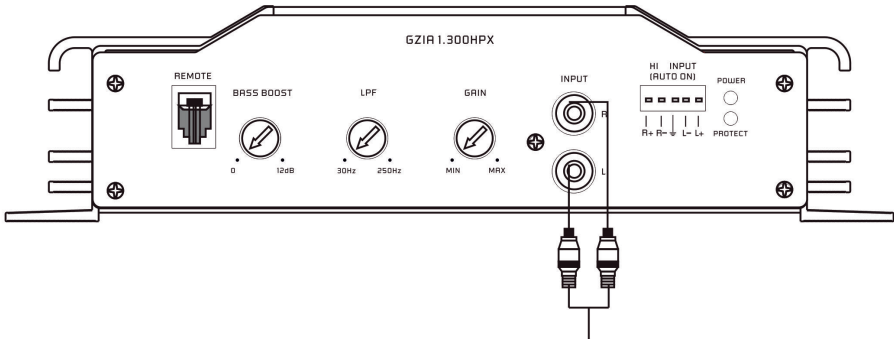

Zum Line out des Autoradios /
To car stereo line out /
Sortie stéréo de la voiture /
Naar line out radio

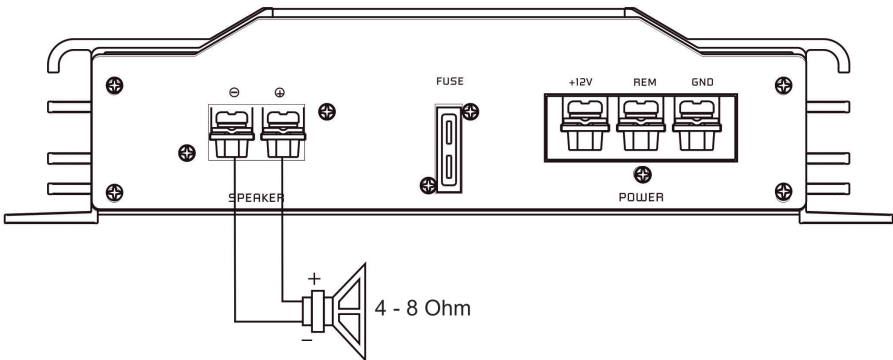

**Lautsprecher Impedanz /
Speaker impedance / Impédance haut parleur
4~8 Ohm**

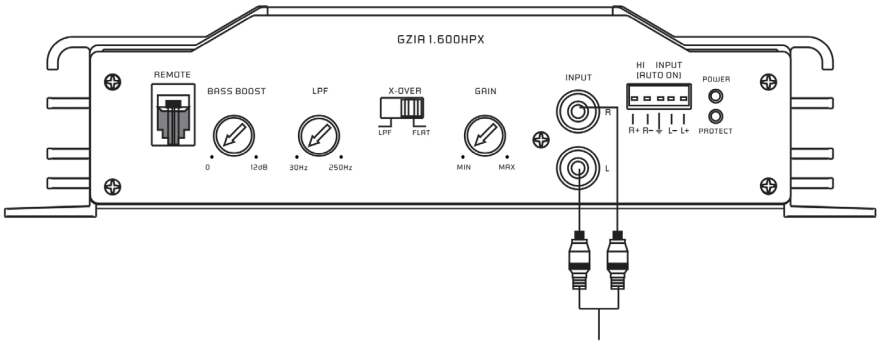

Zum Line out des Autoradios /
To car stereo line out /
Sortie stéréo de la voiture /
Naar line out radio

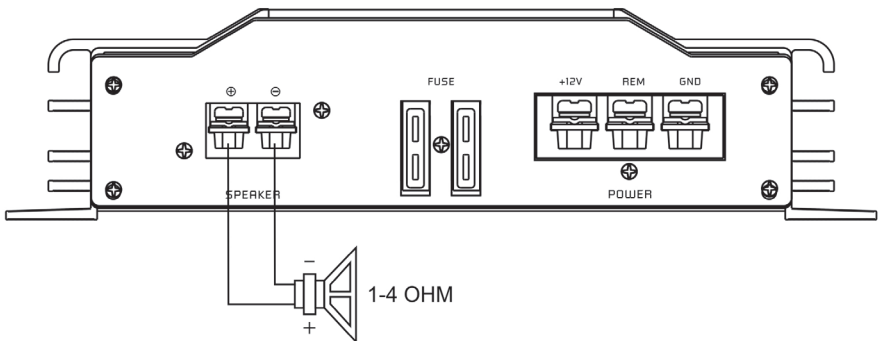

**Lautsprecher Impedanz /
Speaker impedance / Impédance haut parleur
1~4 Ohm**

Stereo wiring – GZIA 2080HPX-B

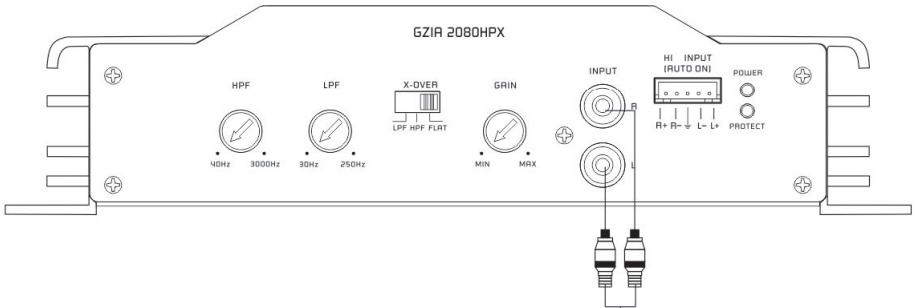

Zum Line out des Autoradios /
To car stereo line out / Sortie stéréo de la voiture /
Naar line out radio

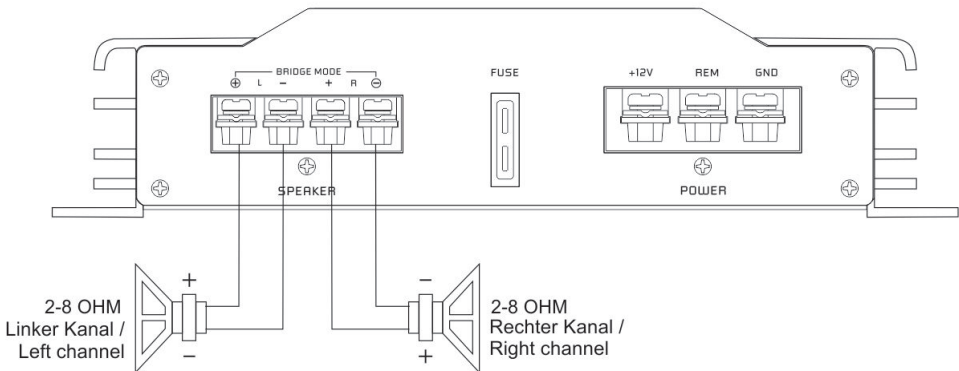

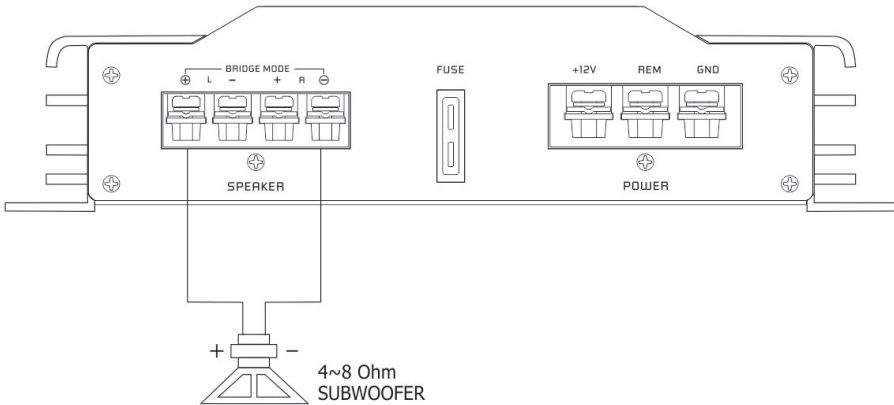

**Lautsprecher Impedanz /
Speaker impedance / Impédance haut parleur
2 ~ 8 Ohm**

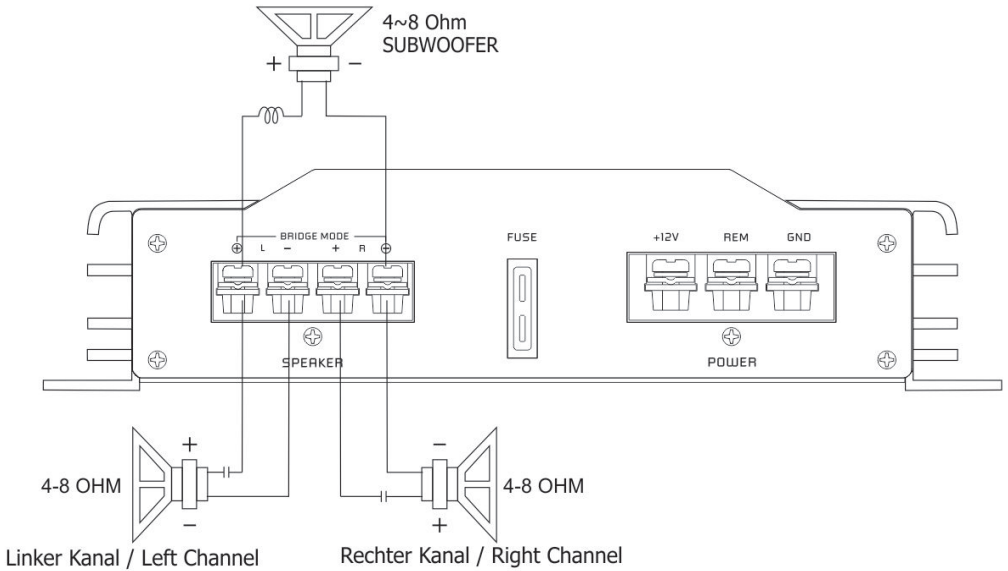

**Lautsprecher Impedanz /
Speaker impedance / Impédance haut parleur
4 ~ 8 Ohm**

Trimode wiring – GZIA 2080HPX-B



- | | |
|---|--|
|  | Spule / Inductor / Filtre Pass bas / Spoel Lowpass Filter |
|  | Kondensator / Capacitor / Condensateur / Condensator Highpass Filter |

Lautsprecher Impedanz / Speaker impedance / Impédance haut parleur 4 ~ 8 Ohm

Stereo wiring – GZIA 2130HPX-B

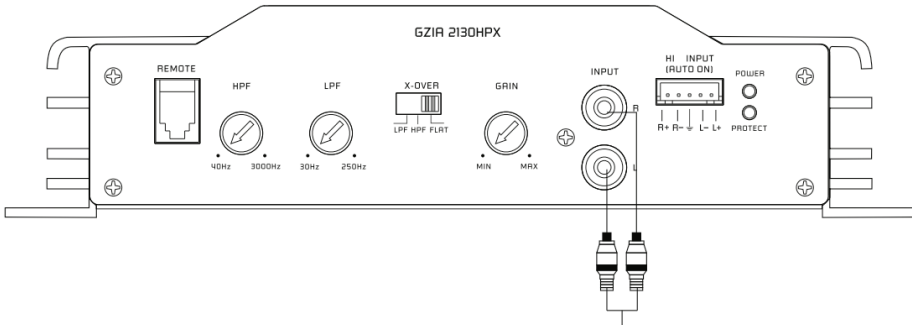

Zum Line out des Autoradios /
To car stereo line out / Sortie stéréo de la voiture /
Naar line out radio

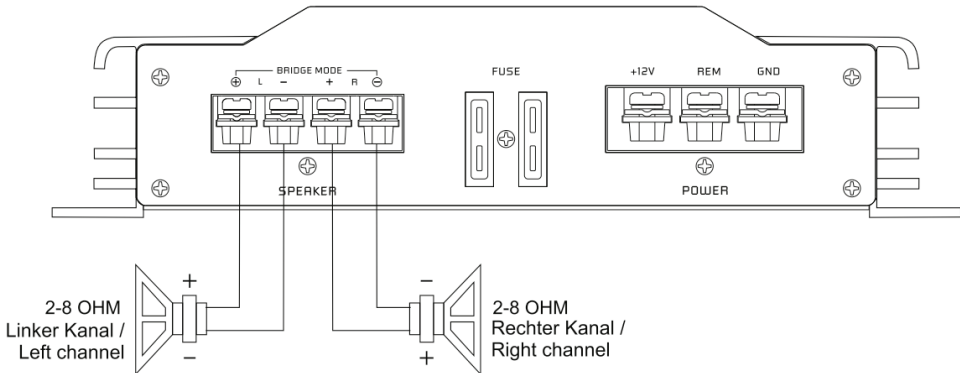

**Lautsprecher Impedanz /
Speaker impedance / Impédance haut parleur
2 ~ 8 Ohm**

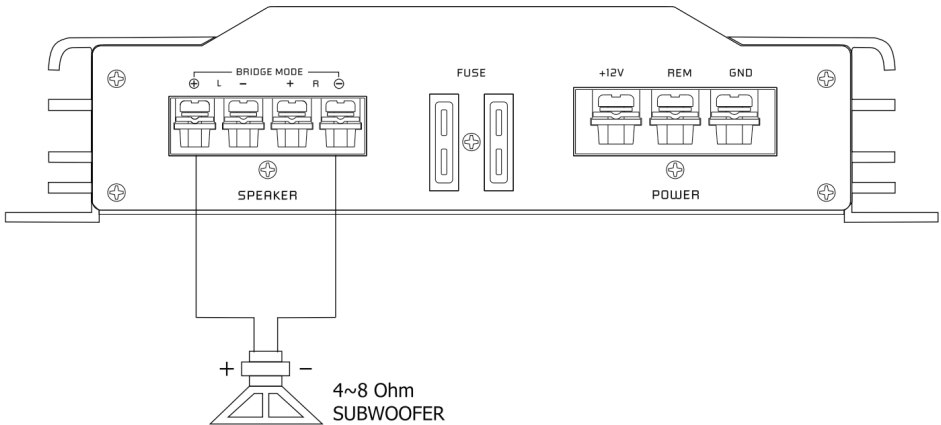

**Lautsprecher Impedanz /
Speaker impedance / Impédance haut parleur
4 ~ 8 Ohm**

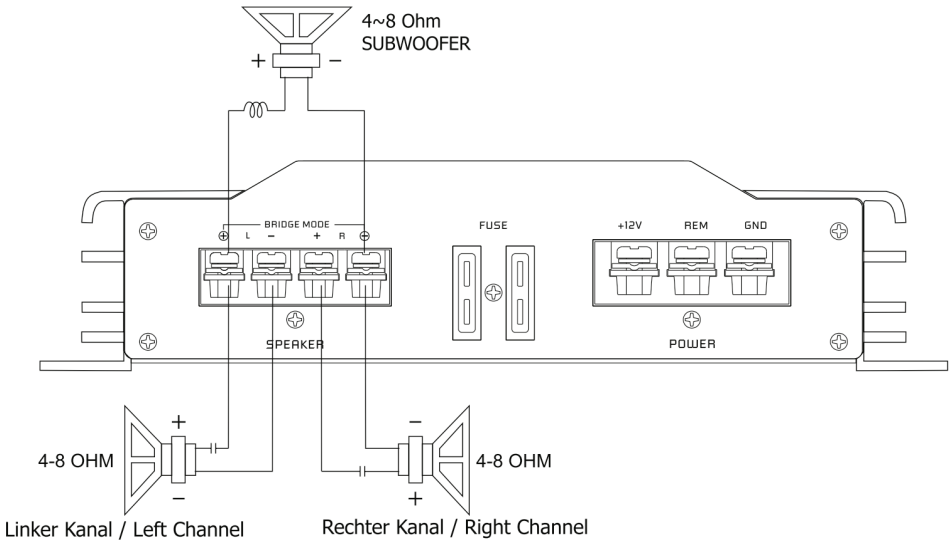

—○— Spule / Inductor / Filtre Pass bas / Spoel Lowpass Filter

—|— Kondensator / Capacitor / Condensateur / Condensator Highpass Filter

Lautsprecher Impedanz / Speaker impedance / Impédance haut parleur 4 ~ 8 Ohm

Stereo wiring – GZIA 2235HPX-B

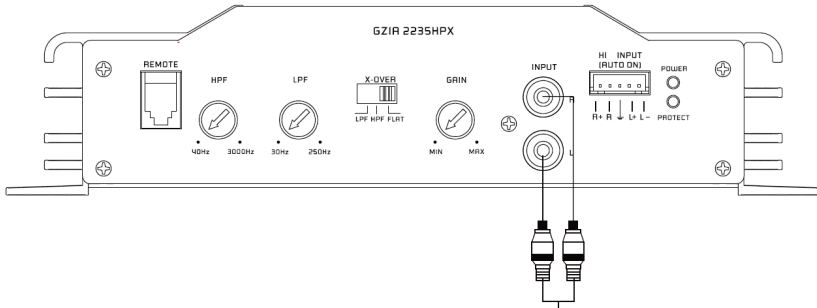

Zum Line out des Autoradios /
To car stereo line out / Sortie stéréo de la voiture /
Naar line out radio

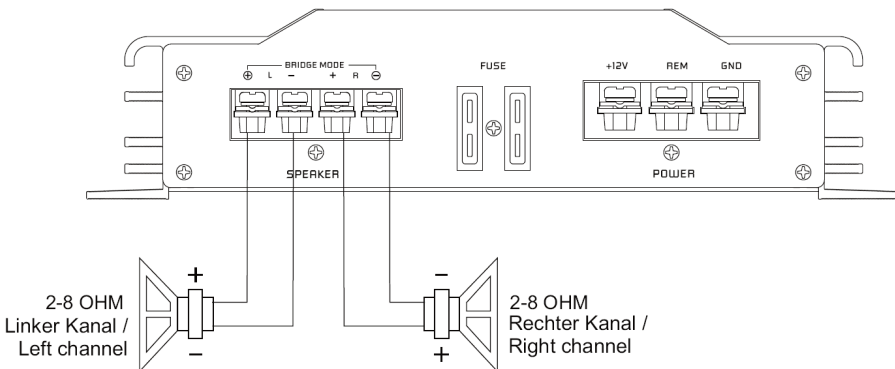

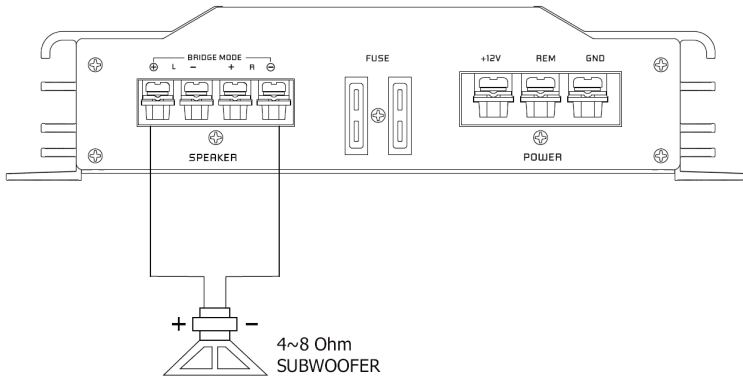

**Lautsprecher Impedanz /
Speaker impedance / Impédance haut parleur
2 ~ 8 Ohm**

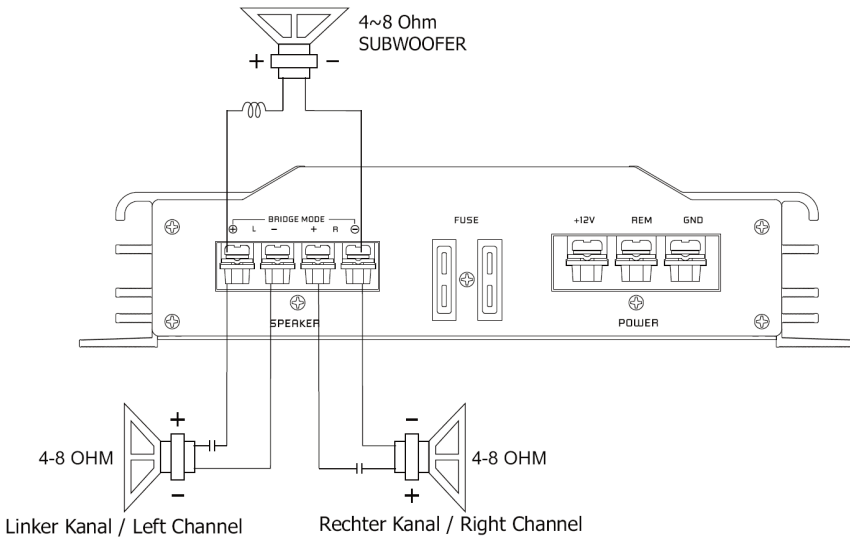

**Lautsprecher Impedanz /
Speaker impedance / Impédance haut parleur
4 ~ 8 Ohm**



- | | |
|---|--|
|  | Spule / Inductor / Filtre Pass bas / Spoel Lowpass Filter |
|  | Kondensator / Capacitor / Condensateur / Condensator Highpass Filter |

**Lautsprecher Impedanz /
Speaker impedance / Impédance haut parleur
4 ~ 8 Ohm**

Stereo wiring – GZIA 4115HPX-B

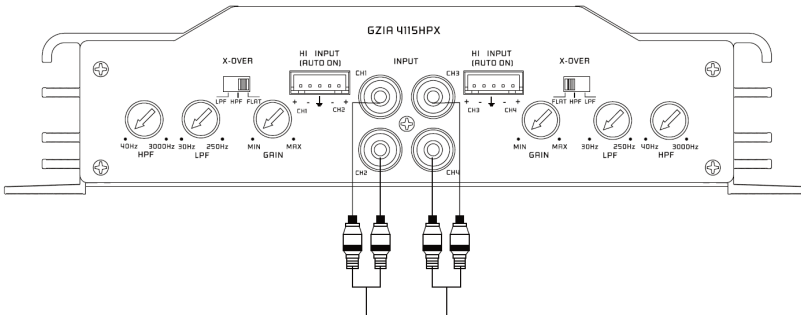

Zum Line out des Autoradios /
 To car stereo line out / Sortie stéréo de la voiture /
 Naar line out radio

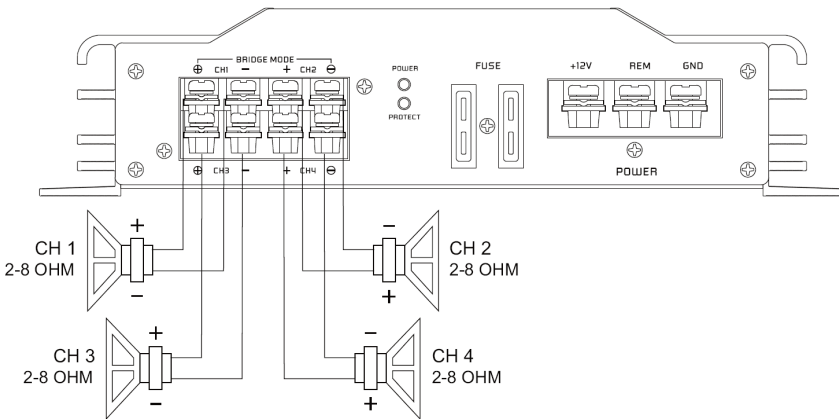

**Lautsprecher Impedanz /
 Speaker impedance / Impédance haut parleur
 2 ~ 8 Ohm**

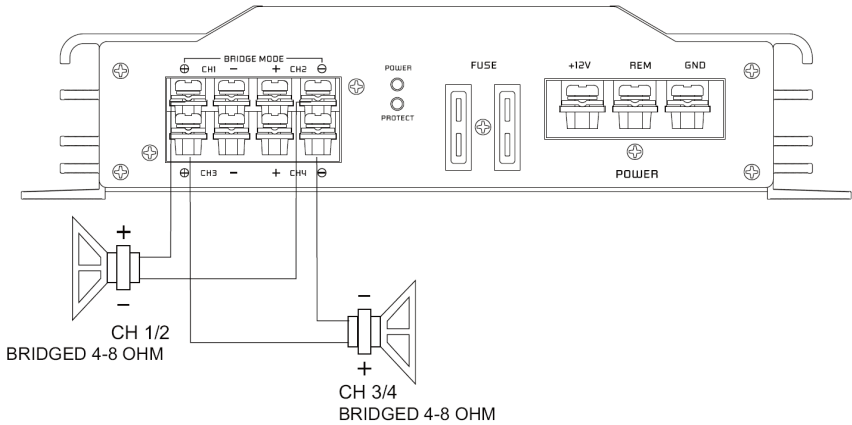

**Lautsprecher Impedanz /
Speaker impedance / Impédance haut parleur
4 ~ 8 Ohm**

Trimode operation – GZIA 4115HPX-B

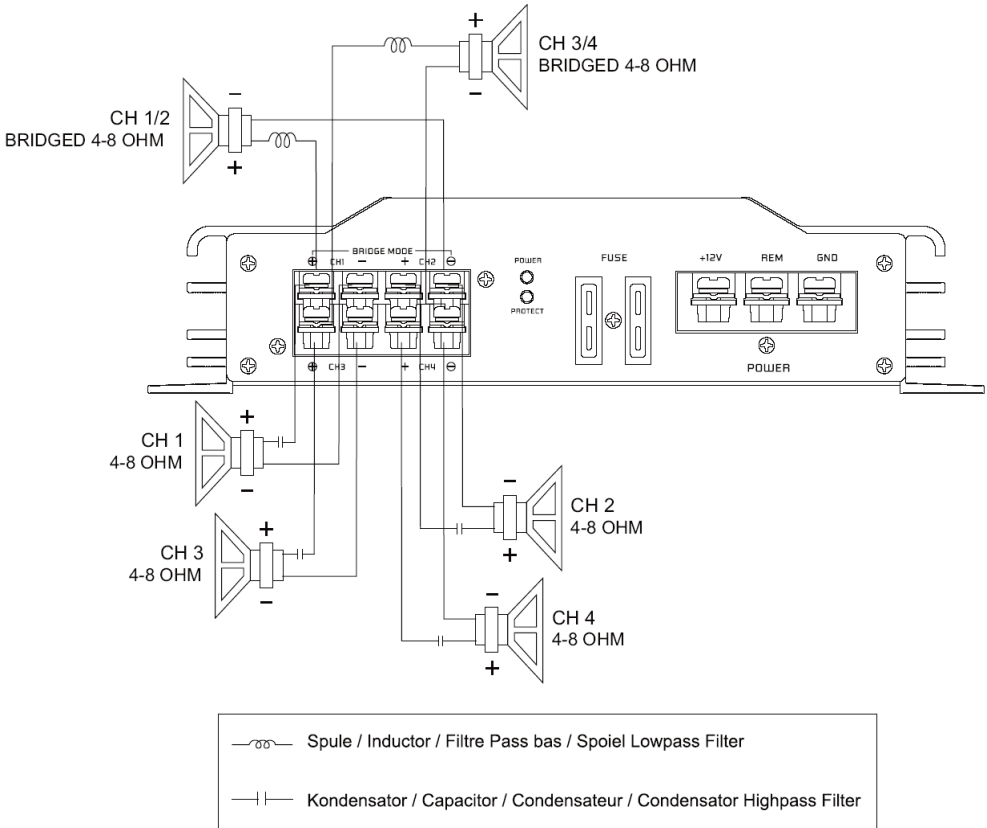

**Lautsprecher Impedanz /
Speaker impedance / Impédance haut parleur
4 ~ 8 Ohm**

Specifications

Model	GZIA 1.300HPX-B	GZIA 1.600HPX-B
Type	1 Channel Class A/B	1 Channel Class A/B
RMS Power @ 4 Ω CEA Standard CEA-2006-A	1 x 200 W (1% THD+N)	1 x 230 W (1% THD+N)
RMS Power @ 2 Ω CEA Standard CEA-2006-A	-	1 x 400 W (1% THD+N)
RMS Power @ 1 Ω CEA Standard CEA-2006-A	-	1 x 600 W (1% THD+N)
MAX Power CEA Standard CEA-2006-A	1 x 300 W @ 4 Ω (10% THD+N)	1 x 700 W @ 1 Ω (10% THD+N)
Damping factor	> 150	> 150
Signal to noise Ratio	> 80 dB	> 80 dB
Lowpass	30 – 250 Hz	30 – 250 Hz
Bass Boost	0 – 12 dB	0 – 12 dB
Highpass	-	-
Frequency response	10 Hz – 250 Hz	10 Hz – 30 KHz
Input sensitivity	200 mV – 6 V	200 mV – 6 V
Bass remote control	✓	✓
Auto-On @ High Input	✓	✓
Fuse	1 x 30A	2 x 30A
Dimensions W x H x L mm	200 x 213 x 50	333 x 213 x 50
Dimensions W x H x L inch	8.39" x 8.39" x 1.97"	13.11" x 8.39" x 1.97"

Specifications

Model	GZIA 2080HPX-B	GZIA 2130HPX-B	GZIA 2235HPX-B	GZIA 4115HPX-B
Type	2 Channel Class A/B	2 Channel Class A/B	2 Channel Class A/B	4 Channel Class A/B
RMS Power @ 4 Ω CEA Standard CEA-2006-A	2 x 60 W (1% THD+N)	2 x 85 W (1% THD+N)	2 x 150 W (1% THD+N)	4 x 70 W (1% THD+N)
RMS Power @ 2 Ω CEA Standard CEA-2006-A	2 x 80 W (1% THD+N)	2 x 130 W (1% THD+N)	2 x 235 W (1% THD+N)	4 x 115 W (1% THD+N)
RMS Power @ 1 Ω CEA Standard CEA-2006-A	-	-	-	-
RMS Power @ 4Ω Bridged CEA Standard CEA-2006-A	1 x 200 W (1% THD+N) 1 x 240 W (10% THD+N)	1 x 260 W (1% THD+N) 1 x 320 W (10% THD+N)	1 x 470 W (1% THD+N) 1 x 540 W (10% THD+N)	2 x 230 W (1% THD+N) 2 x 250 W (10% THD+N)
Damping factor	> 150	> 150	> 100	> 100
Signal to noise Ratio	> 85 dB	> 85 dB	> 80 dB	> 80 dB
Lowpass	30 – 250 Hz	30 – 250 Hz	30 – 250 Hz	30 – 250 Hz
Highpass	40 – 3000 Hz	40 – 3000 Hz	40 – 3000 Hz	40 – 3000 Hz
Frequency response	10 Hz – 30 KHz	10 Hz – 30 KHz	10 Hz – 30 KHz	10 Hz – 30 KHz
Input sensitivity	200 mV – 6 V	200 mV – 6 V	200 mV – 6 V	200 mV – 6 V
Bass remote control	-	✓ (optional)	✓	-
Auto-On @ High Input	✓	✓	✓	✓
Fuse	1 x 20A	2 x 15A	2 x 25A	2 x 25A
Dimensions W x H x L mm	175 x 213 x 50	215 x 213 x 50	285 x 213 x 50	285 x 213 x 50
Dimensions W x H x L inch	6.89" x 8.39" x 1.97"	8.46" x 8.39" x 1.97"	11.22" x 8.39" x 1.97"	11.22" x 8.39" x 1.97"

Trouble shooting guide

Symptoms	Check Points	Cure
No sound	Is the POWER LED illuminated?	Check fuses in amplifier. Be sure remote lead is connected. Check signal leads. Check again control. Check tuner/deck volume level.
	Is the diagnostic LED illuminated?	Check for speaker short or amplifier overheating
Amp not switching on	No power to the amplifier	Check power wire or connections
	No power to remote wire with receiver on	Check connections to radio
No sound in one channel	Check speaker leads	Inspect for short circuit or an open connection
	Check audio leads	Reverse left and right RCA inputs to determine if it is occurring before the amp
Amp turning off at medium / high volume	Check speaker load impedance	Be sure proper speaker load impedance recommendations are observed (If you use an ohm meter to check speaker resistance, please remember that DC resistance and AC impedance may not be the same.)
Protection LED is on	Temperature shut down	Turn radio volume down
	Speaker wires short	Separate speaker wires and insulate

Die Gewährleistung entspricht der gesetzlichen Regelung. Eine Rücksendung kann nur nach vorheriger Absprache und in der Originalverpackung erfolgen. Bitte unbedingt einen maschinell erstellten Kaufbeleg und eine Fehlerbeschreibung beilegen. Von der Gewährleistung ausgeschlossen sind Defekte, die durch Überlastung, unsachgemäße Behandlung oder bei Teilnahme an Wettbewerben entstanden sind. Wir behalten uns das Recht vor, zukünftig nötige Änderungen oder Verbesserungen an dem Produkt vorzunehmen ohne den Kunden darüber zu informieren.

Limited warranty - defective products must be returned in original packaging - please add a copy of the original purchasing invoice showing the purchasing date and a detailed description of the failure. Failure caused by overload, misuse or by using the product for competition purpose are not covered by the warranty. We reserve the right to make needed change or improvement to the product without informing customer about this in advance.

De Garantie bepalingen van alle door ground zero geleverde producten is volgens wettelijke bepalingen geregeld. Een retourzending kan alleen na duidelijke afspraak en in de originele verpakking plaatsvinden. SVP een aankoopbon en een duidelijke storingsomschrijving bijvoegen. Van garantie uitgesloten zijn defecten door overbelasting, onkundig gebruik, of door deelname aan wedstrijden (SPL) ontstaan zijn. Wij behouden ons het recht om de nodige veranderingen of verbeteringen aan het product door te voeren zonder de klant hierover te informeren.

La garantie est conforme aux droits légaux. Un retour du produit défectueux doit être dans son emballage d'origine sur présentation du reçu ou de la facture indiquant la description du défaut. La présente Garantie n'est pas applicable lorsque le produit a été endommagé en raison: Mauvaise alimentation, TROP de puissance (HP, Subwoofer) Accident, Installation ou Utilisation non conforme aux normes Technique (Concours SPL etc). Nous nous réservons le droit d'entreprendre à l'avenir nécessairement des modifications ou des améliorations au produit sans informer le client.

Ground Zero GmbH

Erlenweg 25, 85658 Egming, Germany

Tel. +49 (0)8095/873 830 Fax -8310

www.ground-zero-audio.com



GROUND ZERO®

GERMAN ENGINEERING

IRIDIUM-SERIES

VAHVISTIMEN

KÄYTTÖOHJE

GZIA 1.300HPX-B

GZIA 1.600HPX-B

GZIA 2080HPX-B

GZIA 2130HPX-B

GZIA 2235HPX-B

GZIA 4115HPX-B

Ominaisuudet

- 4 Ohm / 2 Ohm vakaa stereo
- 4 Ohm vakaa Mono (GZIA 1.300HPX-B)
- 1 Ohm vakaa Mono (GZIA 1.600HPX-B)
- Virta & suojaus merkkivalo
- Bass Boost (GZIA 1.300HPX-B / 1.600HPX-B)
- Säädettävä ylipäästösuodin (GZIA 2080HPX-B / 2235HPX-B / 2130HPX-B / 4115HPX-B)
- Säädettävä alipäästösuodin
- Auto-On @ High Level sisääntulosta
- Säädettävä sisääntuloherkkyys
- Käynnistyksen viivepiiri
- Bassonkukosäädin (GZIA 1.300HPX-B / 1.600HPX-B / 2235HPX-B, 2130HPX-B valinnainen)
- Lämpö / oikosulku / ylikuormitus suoja

Työkalut ja tarvikkeet mitä tarvitset vahvistimen asennukseen

- Ruuvimeisseli
- Porakone, 3 mm / 0.12" poranterä
- Kiinnitysruuvit
- Virtajohto min. 10 mm²
- Maajohto min. 10 mm²
- Kaiutinjohto min. 2 x 1,5 mm²

HUOM!

- Varmuuden vuoksi on hyvä irroittaa auton maakaapeli ennen vahvistimen virtaliittimien kytkentöjä. (Katso auton käyttöoppaasta tarkemmat tiedot).
- Käytä varovaisuutta poratessasi mahdollisia reikiä auton tavaratilassa. Polttoaine- ja jarruputket saattavat vaurioitua reikää poratessasi – tämä voi aiheuttaa vakavia turvallisuusriskejä.
- Älä koskaan vedä johtoja terävien kulmien ja reunojen yli. On suositeltavaa käyttää min. 1 faradin kondensaattoria takaamaan vahvistimen vakaamman jännitteen saannin.

VAROITUS!

Tehokkaat autohifijärjestelmät ovat kykeneviä tuottamaan Live-konserttitasoisia äänenpaineita. Jatkuva altistuminen korkeille äänenpaineilta saattaa vaurioittaa kuuloasi pysyvästi. Myöskin korkea kuunteluvoimakkuus saattaa estää sinua kuulemasta ajoneuvon ulkopuolisia ääniä kuten; torvien ja hälytysajoneuvojen sireeniä.

Järjestelmän suunnittelu

Ennen asennuksen aloittamista, harkitse seuraavaa:

Jos harkitset järjestelmän laajentamista tulevaisuudessa, varmista että tilaa on riittävästi, ja vaatimukset jäähdytykselle täyttyvät myös tulevaisuudessa laitteiden määrän lisääntyessä.

Vahvistimen asentamisesta

- a. Valitse sopiva asennuspaikka, johon saat johdotuksen ja jossa on riittävästi tilaa ilmankierrolle sekä jäähdytykselle.
- b. Käytä vahvistinta mallina kun merkkat kiinnitysreiat.

Varoitus

Valitse asennuspaikka siten että kaikki johdot ovat suojassa teräviltä kulmilta, lämmöltä tai muilta vaurioittavilta osuhteilta. Virtakaapeli tulee suojata päävirtasulakkeella mahdollisimman läheltä akkua. Varmista että ohjelmalähteesi ja kaikki muut järjestelmän laitteet ovat pois päältä kytkentöjä tehdessäsi.

Jos sinun täytyy vaihtaa sulake, korvaa se ainoastaan alkuperäisen kokoisella sulakkeella. Eri kokoisen tai tyypisen sulakkeen käyttö voi vahingoittaa laitteistoasi, mikä ei kuulu takuun piiriin.

Kytkimet ja toiminnot – GZIA 1.300HPX-B

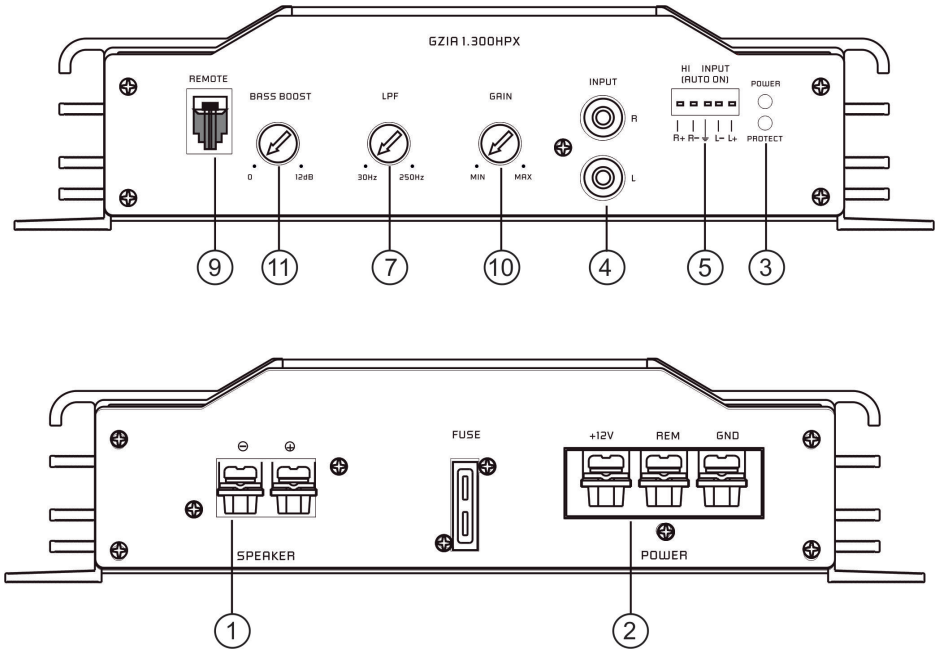

Kytkimet ja toiminnot – GZIR 1.600HPX-B

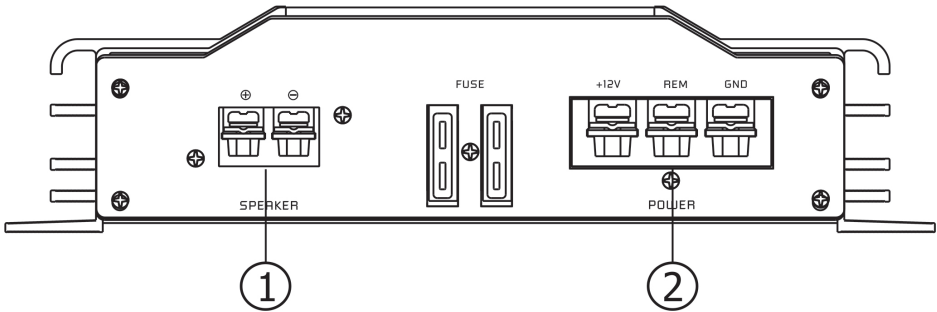
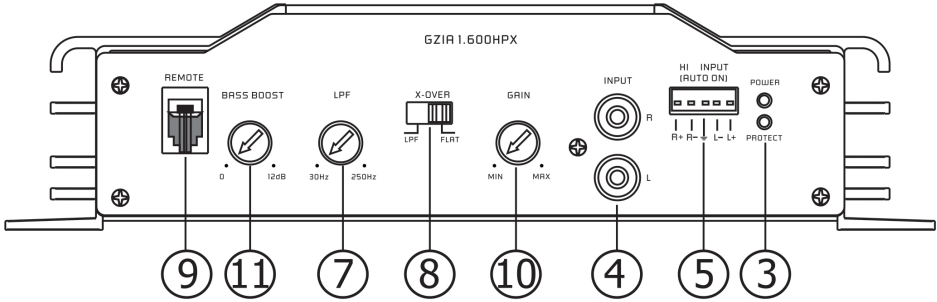

Kytkimet ja toiminnot – GZIA 2080HPX-B

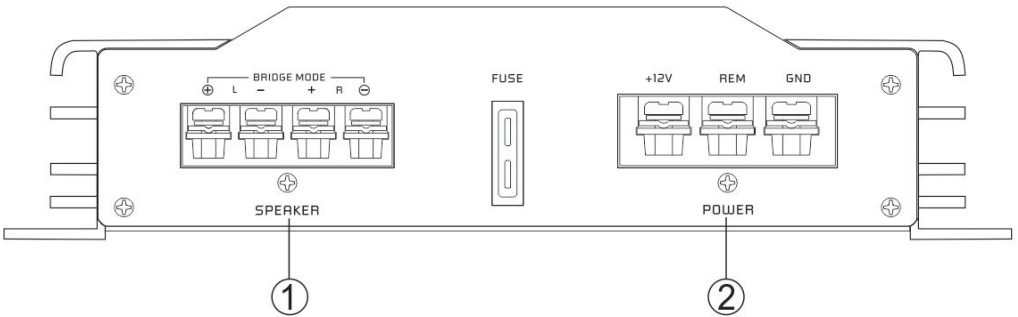
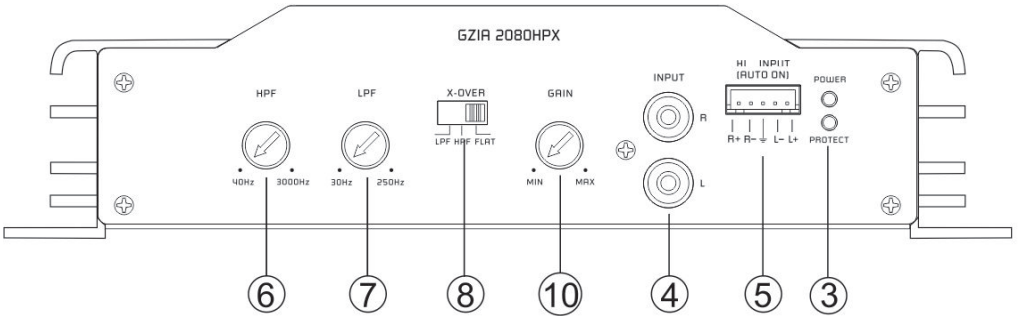

Kytkimet ja toiminnot – GZIA 2130HPX-B

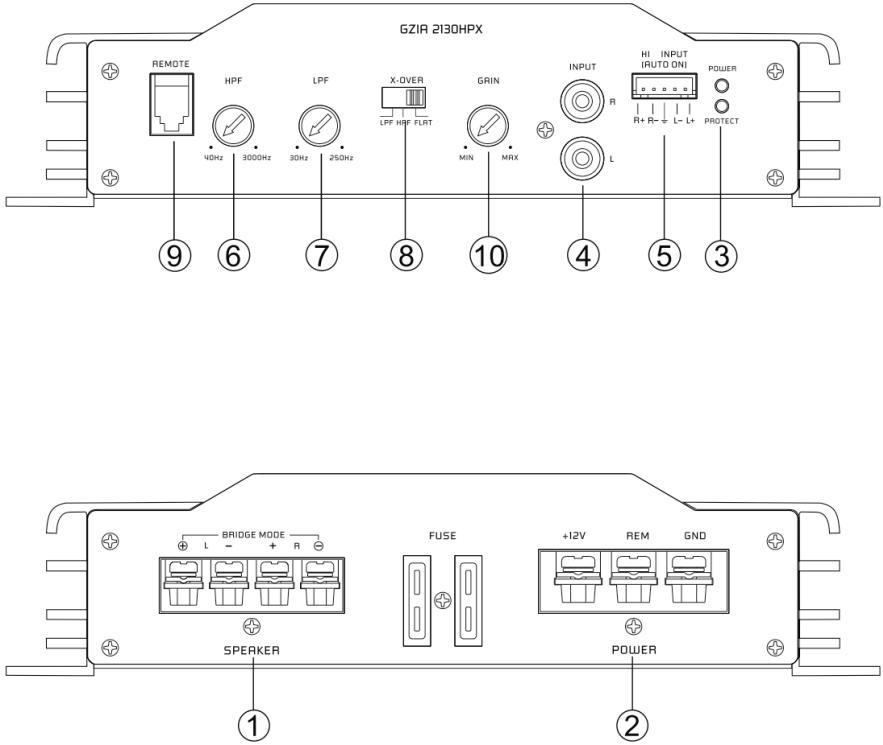

Kytkimet ja toiminnot – GZIA 2235HPX-B

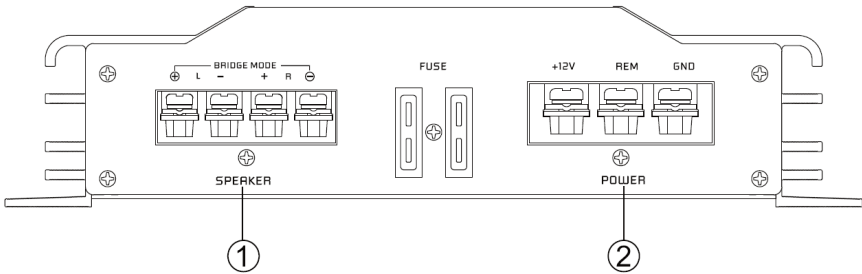
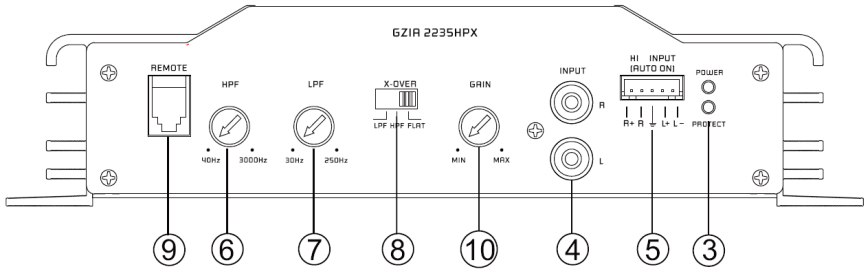

Kytkimet ja toiminnot – GZIA 4115HPX-B

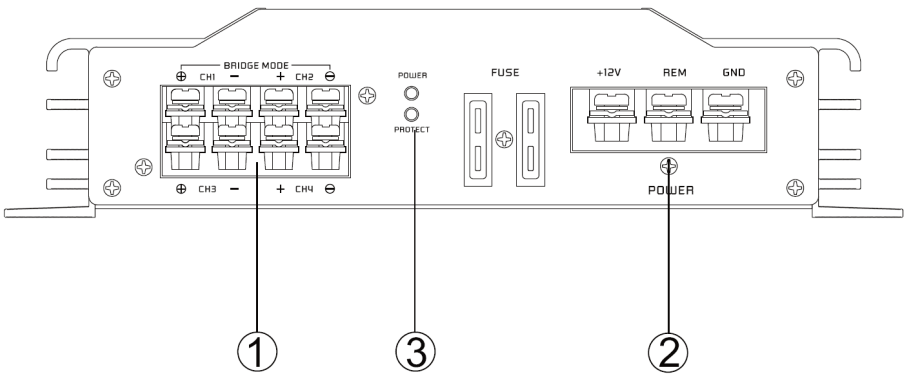
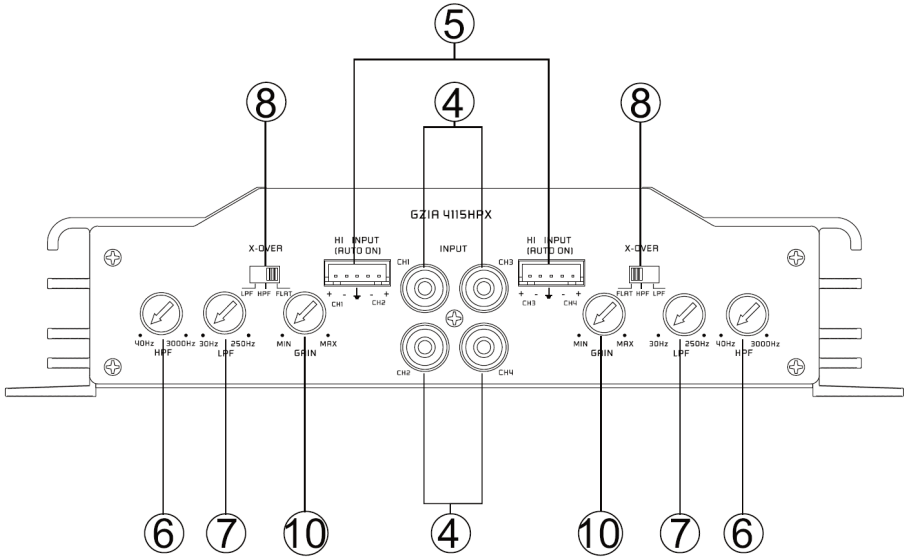

Kytkimet ja toiminnot

1	Kaiutinliittimet	Kaiutinjohdot
2	Virtaliittimet	GND -> Maadoitusjohto REM -> Herätevirta BATT -> +12 Volttia
3	Tilan merkkivalo	VIHREÄ – OK PUNAINEN – VIRHE
4	RCA sisääntulo	Signaaliikaapelit. Häiriöiden välttämiseksi, käytä hyvälaatuisia RCA-johtoja. TÄRKEÄÄ! Älä käytä High level sisääntuloa ja RCA-sisääntuloa rinnakkain, tämä voi vahingoittaa vahvistinta.
5	High Level (kaiutintasoinen) sisääntulo	Käytä tätä sisääntuloa mikäli soittimessasi ei ole RCA-ulostuloja. Kytke kaiutintasoinen signaali tähän liittimeen. Vahvistin käynnistyy automaattisesti tunnistettuaan signaalin (Auto On). Remote-sisääntuloa vahvistimen virtaterminaalissa ei täten tarvitse kytkeä. TÄRKEÄÄ! Älä käytä High level sisääntuloa ja RCA-sisääntuloa rinnakkain, tämä voi vahingoittaa vahvistinta.
6	Ylipäästösuojin	Aseta kytkin „HIGH” asentoon. Säädä portaaton ylipäästön jakotaajuus halutulle taajuudelle. Kaikki taajuudet välillä 40 ja 3000 Hz toistuvat.
7	Alipäästösäädin	Ainoastaan taajuudet 30 Hz - 250 Hz toistuvat (riippuen LPF suotimen säätimen asennosta). Aseta kytkin asentoon „LOW” ja säädä haluttu jakotaajuus.
8	Mode- kytkin	Säädä jakosuotimen kytkin haluttuun asentoon. LPF – Ainoastaan bassotaajuudet (alle 30Hz - 250Hz) toistuvat. FLAT – Kaikki taajuudet toistuvat. HPF – Ainoastaan keski- ja korkeat taajuudet (yli 40 Hz – 3000 Hz) toistuvat.
9	Kaukosäätimen liittäminen	Liitin bassontasonkaukosäädölle.
10	Sisääntulotason säätö	Tällä säätimellä säädät sisääntulotason sopivaksi. (2130HPX/2235HPX/1.600HPX)
11	Bass Boost	Säätäessä Bass Boostia 45hz alueella, 0 – 12 dB

High Level (kaiutintasoinen) sisääntulo

Auto-On toiminto mahdollistaa vahvistimen käytön ilman erillistä remote-kytkentää. Tämä mahdollistaa vahvistimen käytön auton alkuperäisen ohjelmälähteen ja mahdollisten aktiivijärjestelmien kanssa, mitkä eivät ole varustettu erillisillä RCA-ulostuloilla.

High Level (kaiutintasoinen) sisääntulo – GZIA 1.300HPX-B

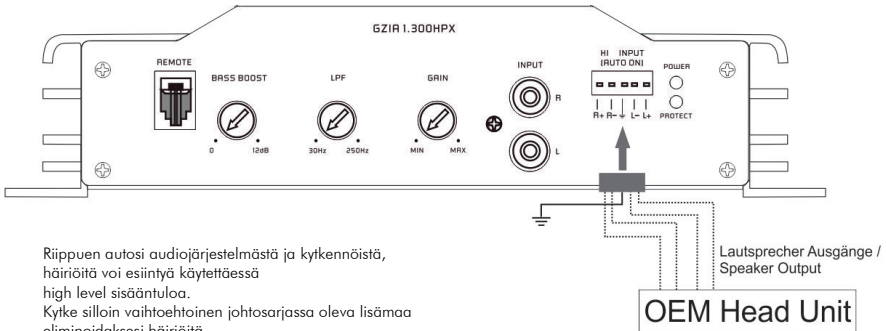

Riippuen autosi audiojärjestelmästä ja kytkennöistä, häiriöitä voi esiintyä käytettäessä high level sisääntuloa. Kytke silloin vaihtoehtoinen johtosarjassa oleva lisämaa eliminoidaksesi häiriöitä. Kytke tämä johto vahvistimen GND virtaterminaaliin.

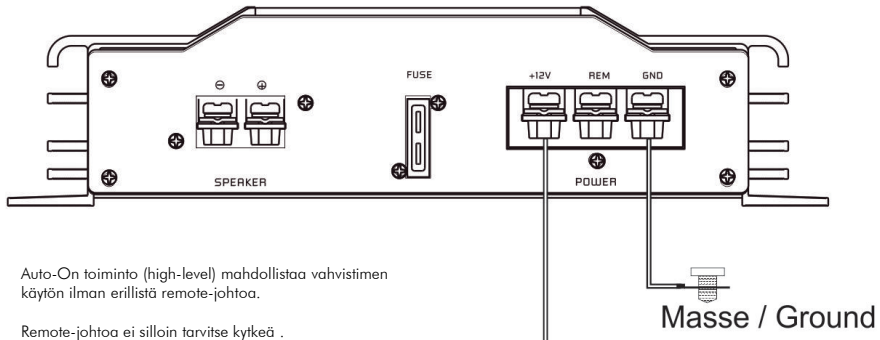

Auto-On toiminto (high-level) mahdollistaa vahvistimen käytön ilman erillistä remote-johtoa.

Remote-johtoa ei silloin tarvitse kytkeä .

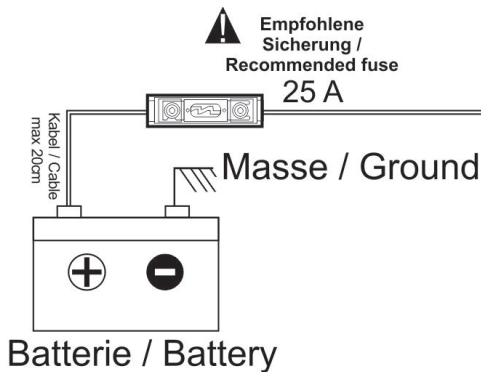

High Level (kaiutintasoinen) sisääntulo – GZ1A 1.600HPX-B

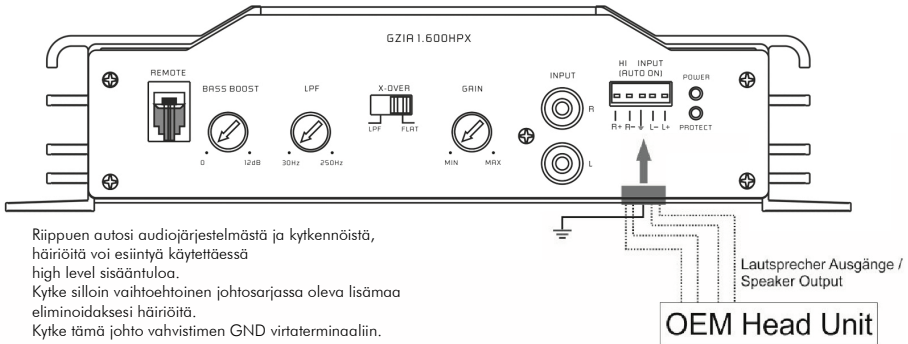

Riippuen autosi audiojärjestelmästä ja kytkennöistä, häiriöitä voi esiintyä käytettäessä high level sisääntuloa. Kytke silloin vaihtoehtoinen johtosarjassa oleva lisämaa eliminoidaksesi häiriöitä. Kytke tämä johto vahvistimen GND virtaterminaaliin.

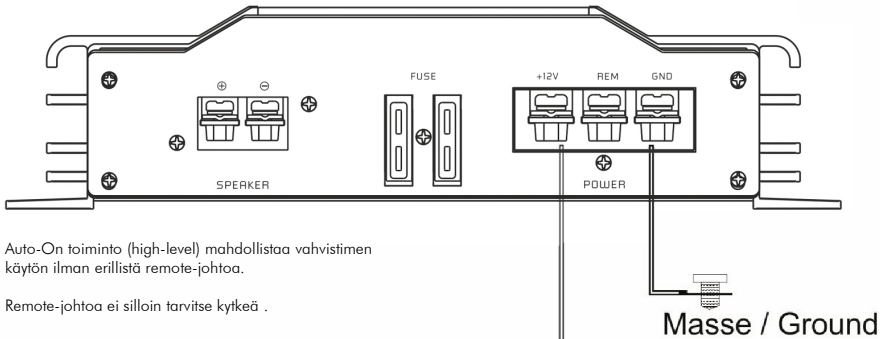

Auto-On toiminto (high-level) mahdollistaa vahvistimen käytön ilman erillistä remote-johtoa.

Remote-johtoa ei silloin tarvitse kytkeä .

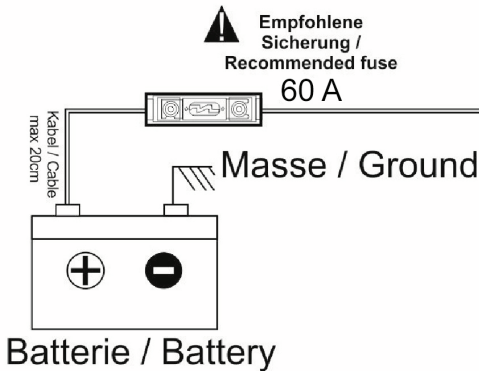

High Level (kaiutintasoinen) sisääntulo – GZIA 2080HPX-B

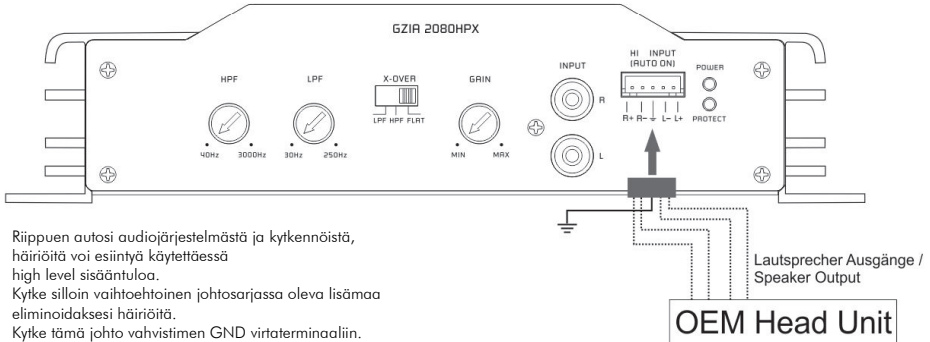

Riippuen autosi audiojärjestelmästä ja kytkennöistä, häiriöitä voi esiintyä käytettäessä high level sisääntuloa. Kytke silloin vaihtoehtoinen johtosarjassa oleva lisämaa eliminoidaksesi häiriöitä. Kytke tämä johto vahvistimen GND virtaterminaaliin.

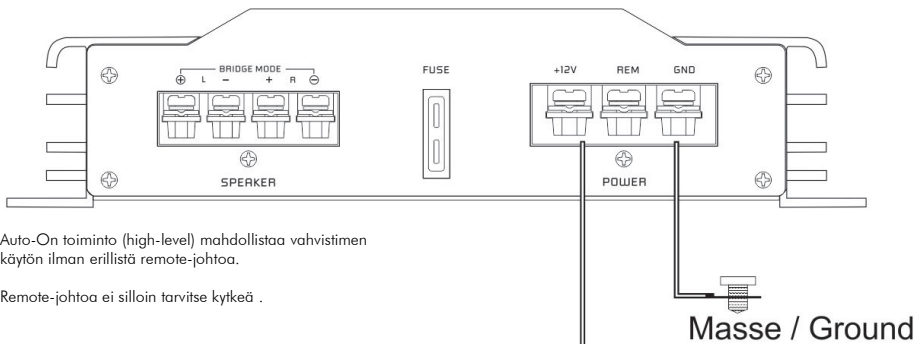

Auto-On toiminto (high-level) mahdollistaa vahvistimen käytön ilman erillistä remote-johtoa.

Remote-johtoa ei silloin tarvitse kytkeä .

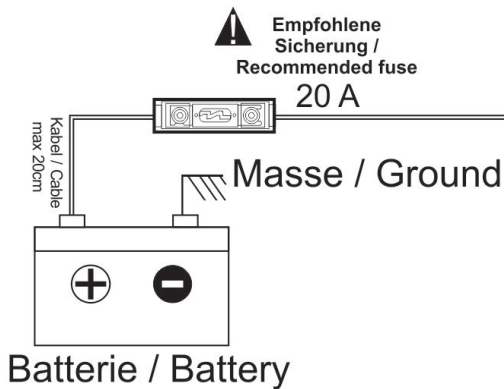

High Level (kaiutintasoinen) sisääntulo – GZIA 2130HPX-B

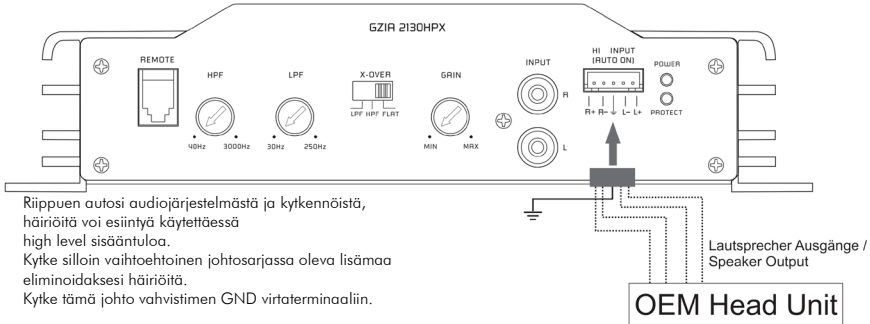

Auto-On toiminto (high-level) mahdollistaa vahvistimen käytön ilman erillistä remote-johtoa.

Remote-johtoa ei silloin tarvitse kytkeä .

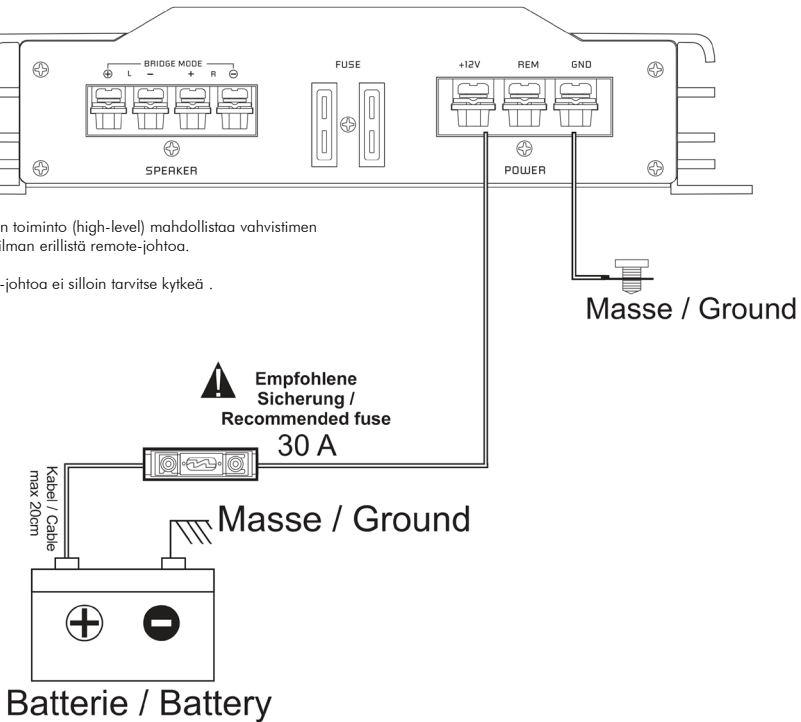

High Level (kaiutintasoinen) sisääntulo – GZIA 2235HPX-B

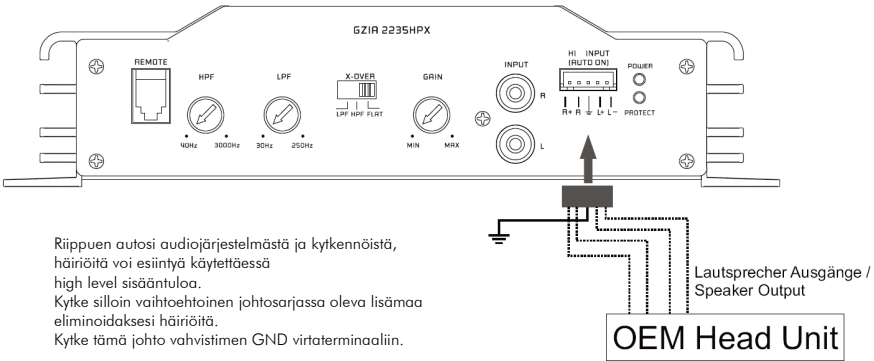

Riippuen autosi audiojärjestelmästä ja kytkennöistä, häiriöitä voi esiintyä käytettäessä high level sisääntuloa. Kytke silloin vaihtoehtoinen johtosarjassa oleva lisämaa eliminoidaksesi häiriöitä. Kytke tämä johto vahvistimen GND virtaterminaaliin.

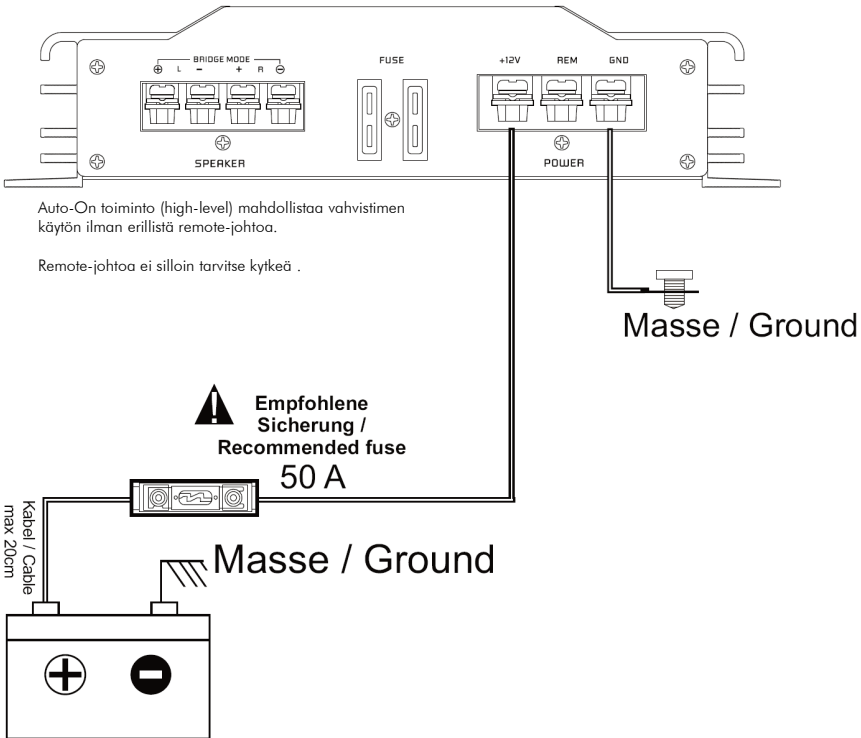

Auto-On toiminto (high-level) mahdollistaa vahvistimen käytön ilman erillistä remote-johtoa. Remote-johtoa ei silloin tarvitse kytkeä .

High Level (kaiutintasoinen) sisääntulo – GZIA 4115HPX-B

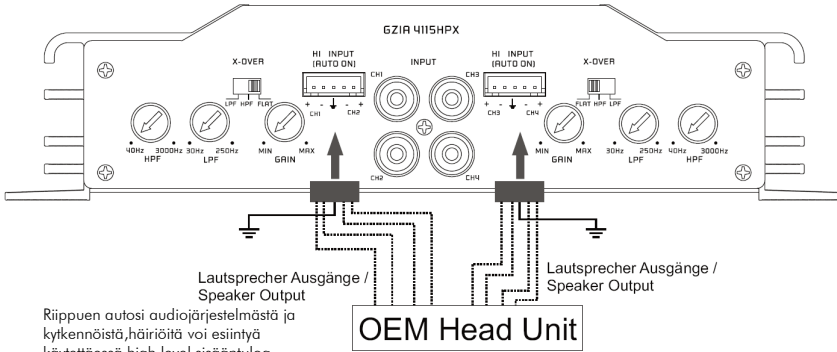

Riippuen autosi audiojärjestelmästä ja kytkennöistä, häiriöitä voi esiintyä käytettäessä high level sisääntuloa. Kytke silloin vaihtoehtoinen johtosarjassa oleva lisämaa eliminoidaksesi häiriöitä. Kytke tämä johto vahvistimen GND virtaterminaaliin.

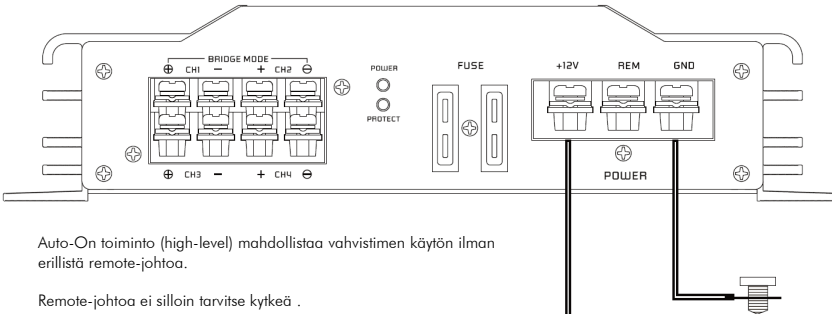

Auto-On toiminto (high-level) mahdollistaa vahvistimen käytön ilman erillistä remote-johtoa.

Remote-johtoa ei silloin tarvitse kytkeä .

Masse / Ground

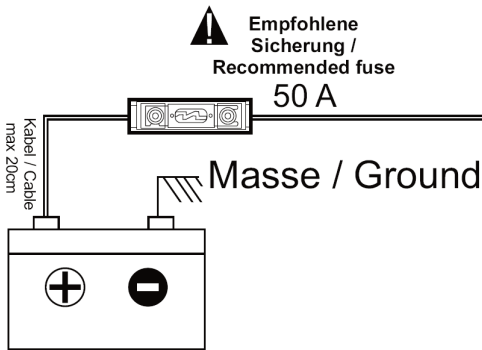

Vahvistimen käynnistys

Kun laitat ohjelmalähteen päälle vahvistin käynnistyy automaattisesti.

Huomaa: Vahvistin kytkeytyy tilapäisesti pois päältä, mikäli sen lämpötila nousee liian kuumaksi. Lämpötilan laskettua normaaliksi vahvistin käynnistyy jälleen automaattisesti. (noin 80°).

Sisääntulon säätö

1. LEVEL (Min/Max): Käännä säädin täysin MIN asentoon
2. Käännä äänenvoimakkuussäädin asentoon kaksi kolmasosaa maksimivoimakkuudesta.
3. Säädä LEVEL-säätimestä tasoa lisää siihen saakka kunnes ääni kuulostaa vielä puhtaalle.

Käyttö Trimode-tilassa - huomioita

TRI MODE käyttö mahdollistaa subwooferin monokäytön, pääkanavien toistaessa stereona. Jätä jakosuotimen kytkin asentoon "Full".

Käytä 100 voltin, non-polar kondensaattoria ylipäästösuojitena suodattaaksesi pois matalat taajuuudet ja ilma- tai rautasydänkeloja alipäästösuojitimelle suodattaaksesi pois korkeat taajuuudet.

Kondensaattoreiden ja kelojen arvot löydät alla olevasta taulukosta. Tässä vahvistimessa on etu ja takakanavissa tämä kytkentä mahdollisuus. Ainoastaan vasen ja oikea takakanava on näytetty oheisessa esimerkki kuvassa.

Arvot 6dB passiivijakosuotimelle

Taajuus	Kela	Kondensaattori
80 Hz	7,5 mH	470 uF
100 Hz	6,5 mH	330 uF
120 Hz	5,5 mH	370 uF
150 Hz	4 mH	220 uF

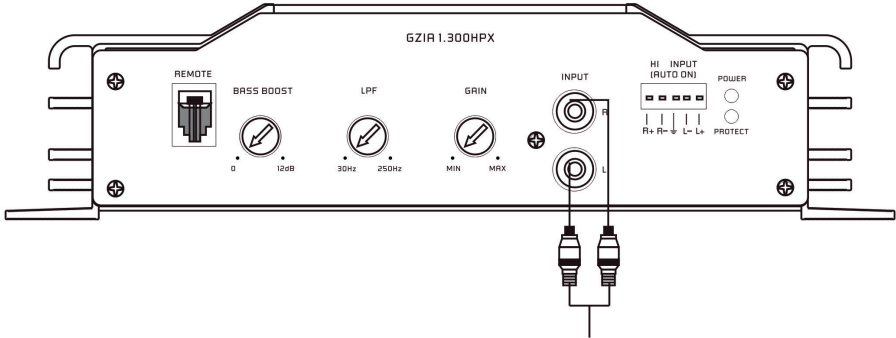

Zum Line out des Autoradios /
To car stereo line out /
Sortie stéréo de la voiture /
Naar line out radio

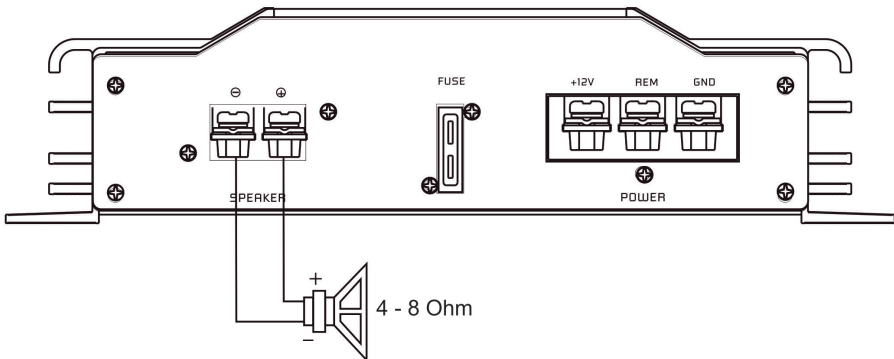

**Lautsprecher Impedanz /
Speaker impedance / Impédance haut parleur
4~8 Ohm**

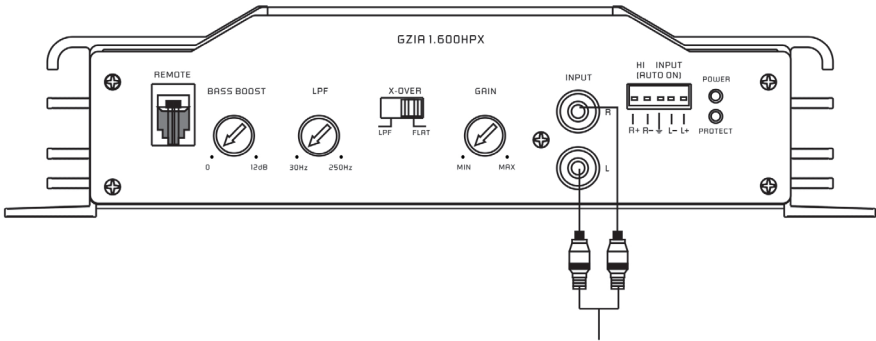

Zum Line out des Autoradios /
To car stereo line out /
Sortie stéréo de la voiture /
Naar line out radio

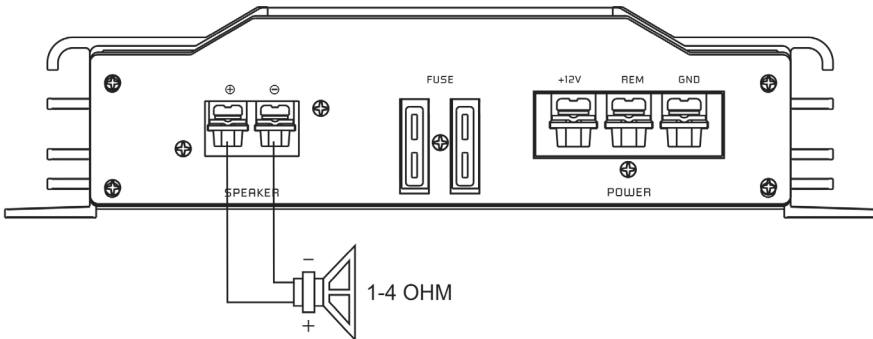

**Lautsprecher Impedanz /
Speaker impedance / Impédance haut parleur
1~4 Ohm**

Stereo kyt Kentä – GZIA 2080HPX-B

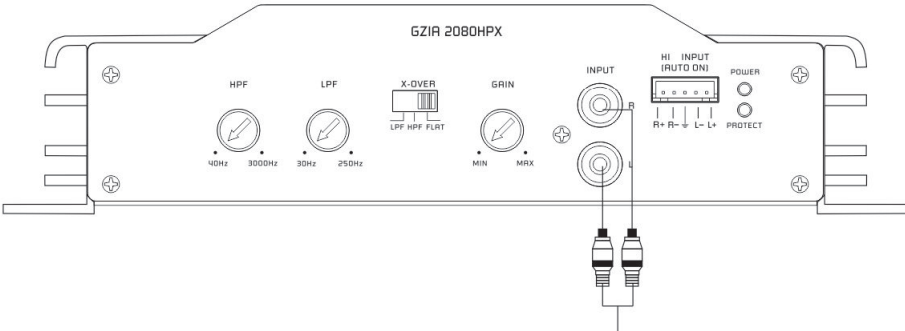

Zum Line out des Autoradios /
To car stereo line out / Sortie stéréo de la voiture /
Naar line out radio

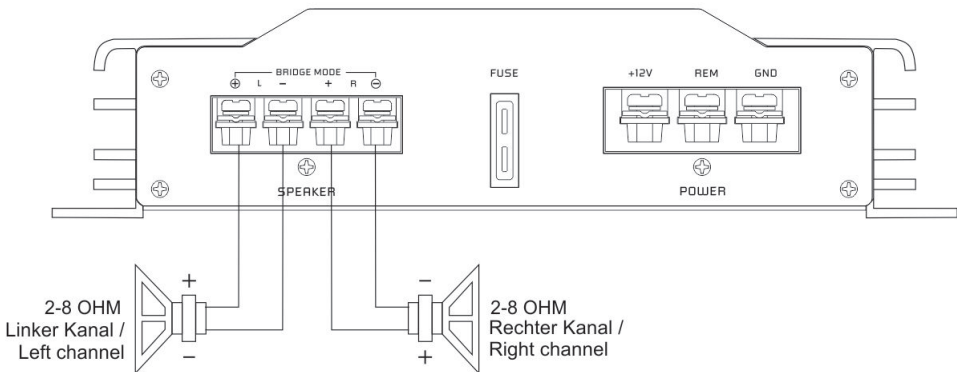

**Lautsprecher Impedanz /
Speaker impedance / Impédance haut parleur
2 ~ 8 Ohm**

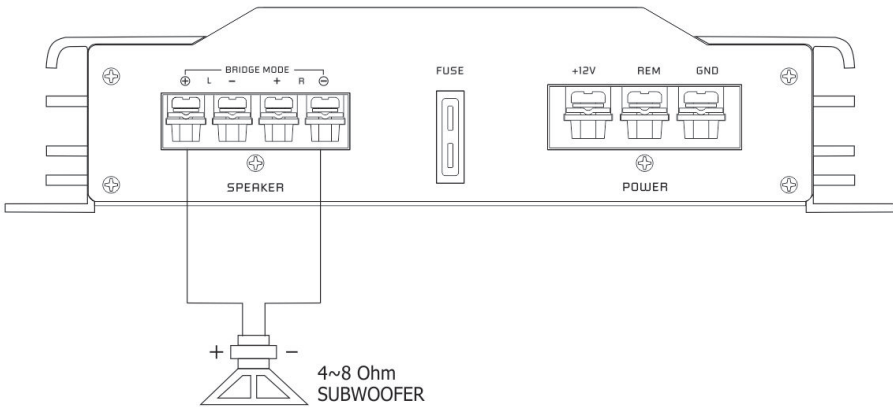

**Lautsprecher Impedanz /
Speaker impedance / Impédance haut parleur
4 ~ 8 Ohm**

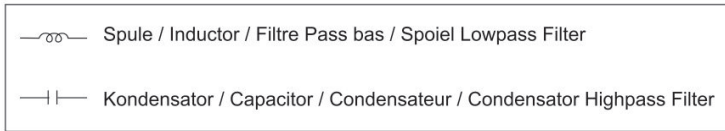
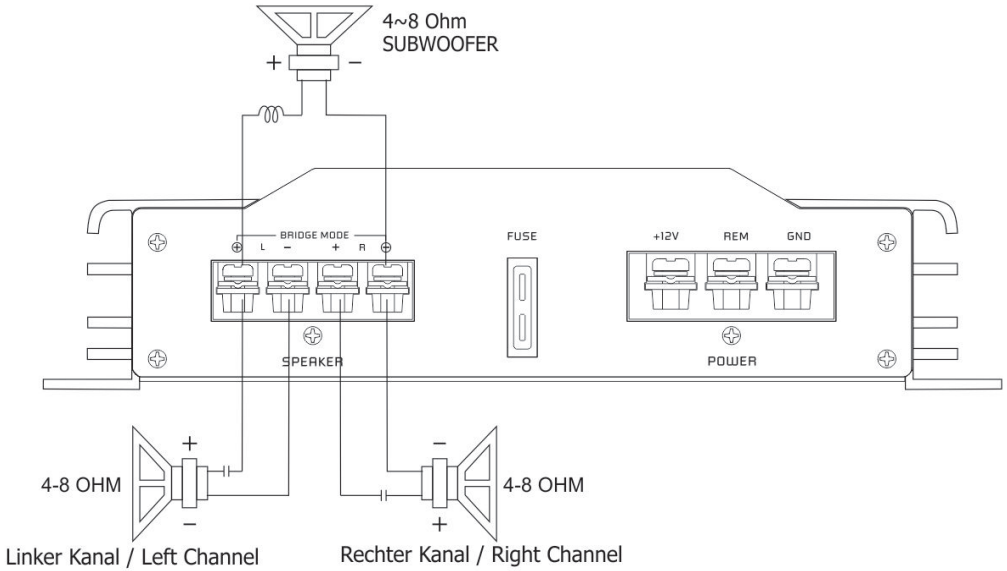

Lautsprecher Impedanz / Speaker impedance / Impédance haut parleur 4 ~ 8 Ohm

Stereo kyt Kentä – GZIA 2130HPX-B

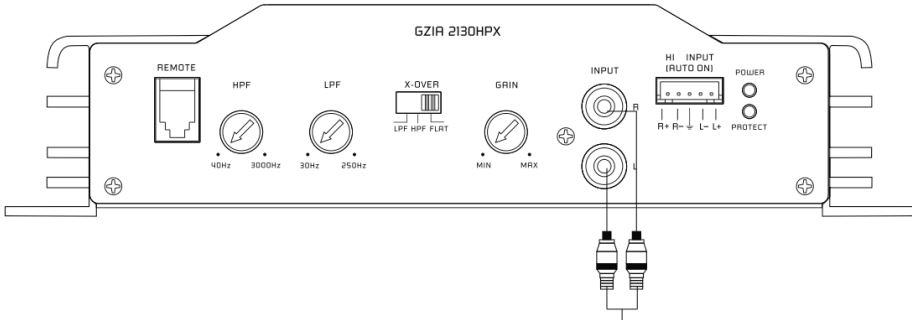

Zum Line out des Autoradios /
To car stereo line out / Sortie stéréo de la voiture /
Naar line out radio

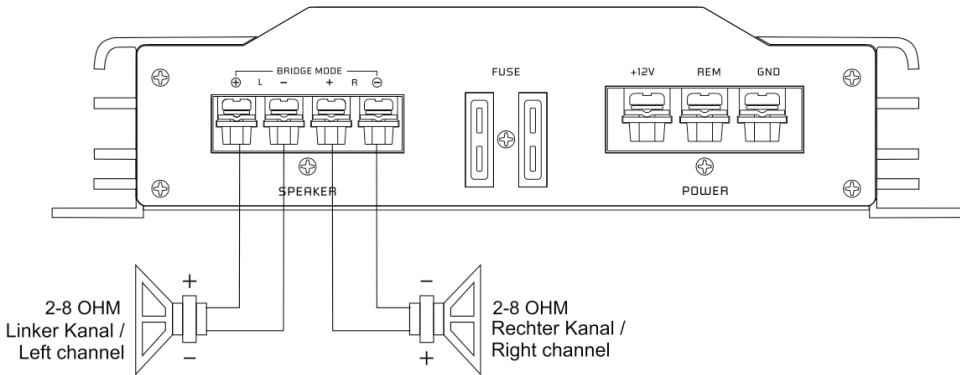

**Lautsprecher Impedanz /
Speaker impedance / Impédance haut parleur
2 ~ 8 Ohm**

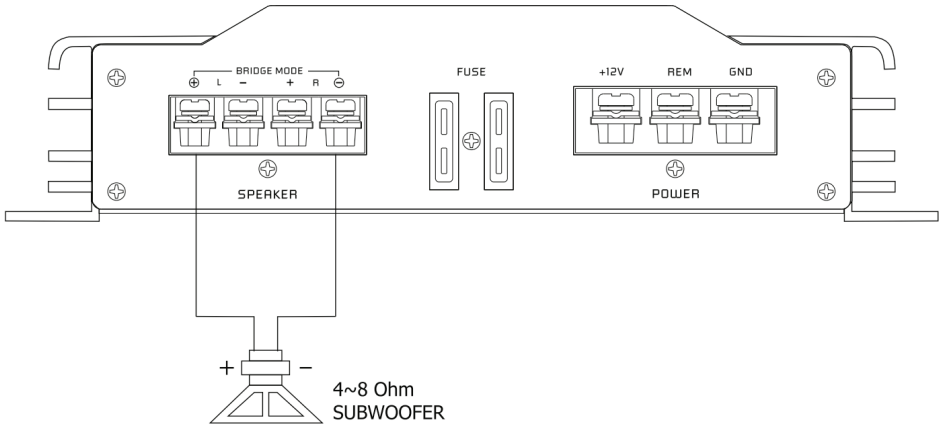

**Lautsprecher Impedanz /
Speaker impedance / Impédance haut parleur
4 ~ 8 Ohm**

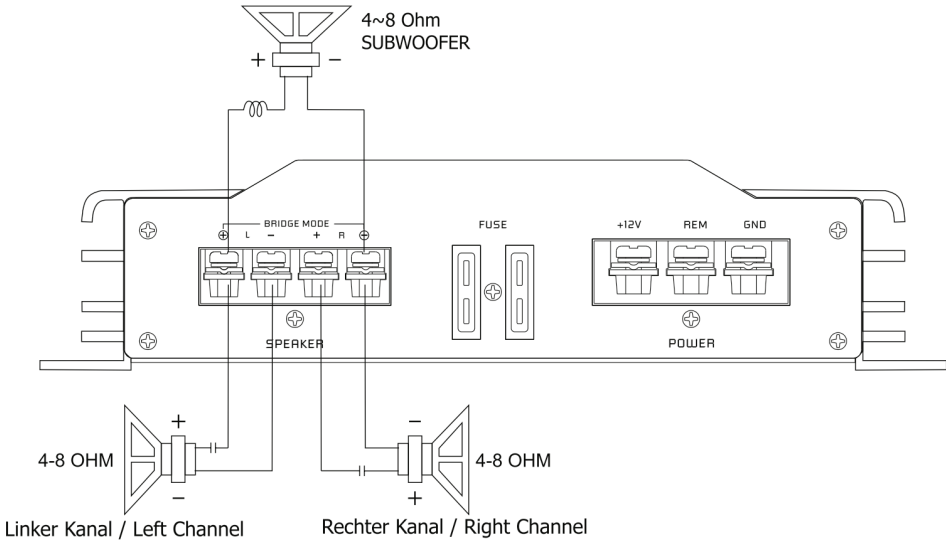

—∞— Spule / Inductor / Filtre Pass bas / Spoel Lowpass Filter

—|— Kondensator / Capacitor / Condensateur / Condensator Highpass Filter

**Lautsprecher Impedanz /
Speaker impedance / Impédance haut parleur
4 ~ 8 Ohm**

Stereo kyt Kentä – GZIA 2235HPX-B

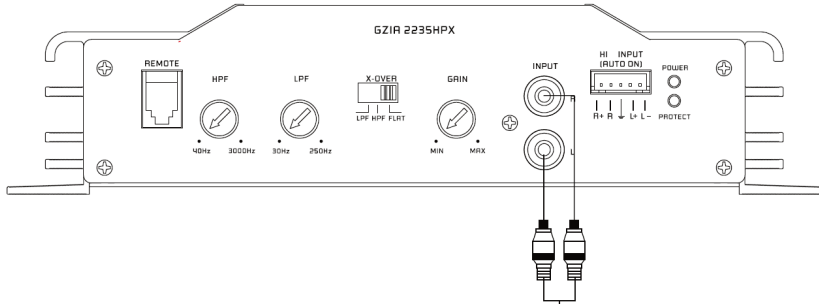

Zum Line out des Autoradios /
To car stereo line out / Sortie stéréo de la voiture /
Naar line out radio

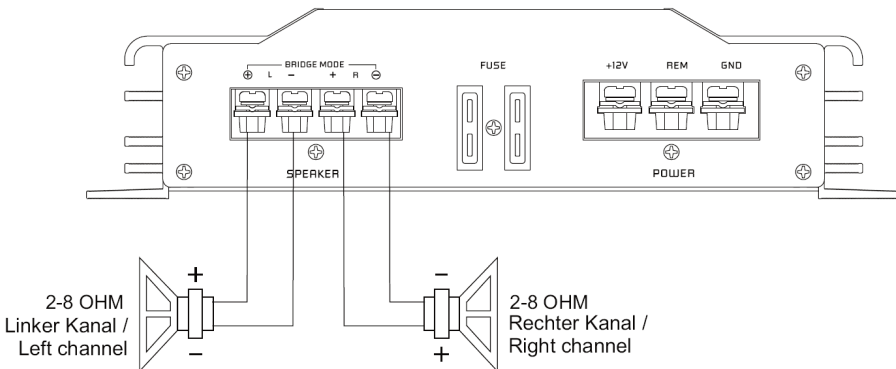

Lautsprecher Impedanz /
Speaker impedance / Impédance haut parleur
2 ~ 8 Ohm

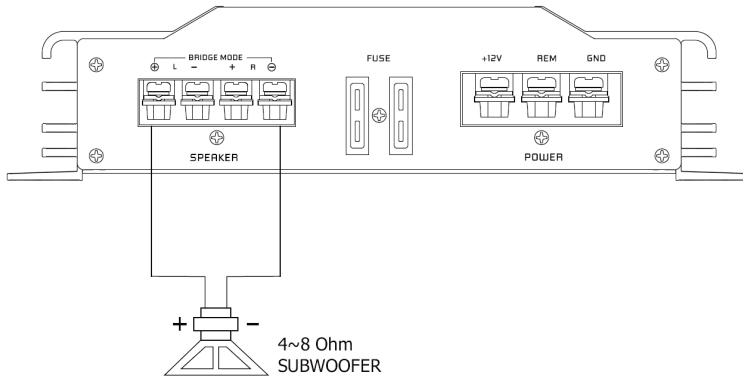

**Lautsprecher Impedanz /
Speaker impedance / Impédance haut parleur
4 ~ 8 Ohm**

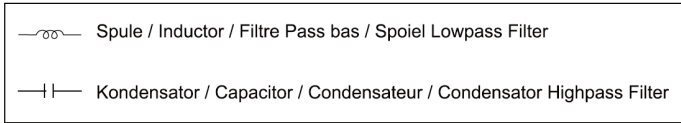
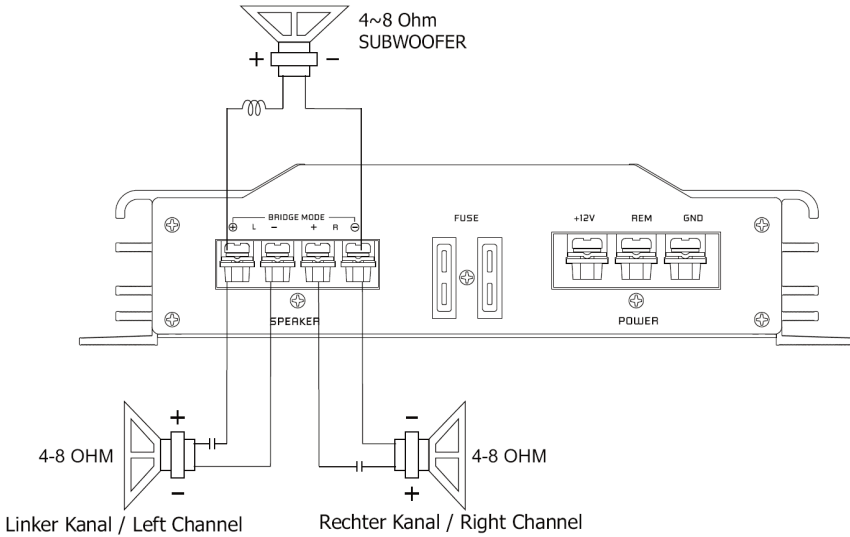

**Lautsprecher Impedanz /
Speaker impedance / Impédance haut parleur
4 ~ 8 Ohm**

Stereo kyt Kentä – GZIA 4115HPX-B

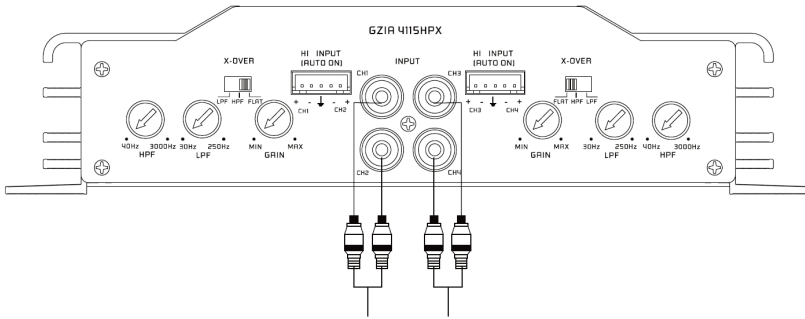

Zum Line out des Autoradios /
 To car stereo line out / Sortie stéréo de la voiture /
 Naar line out radio

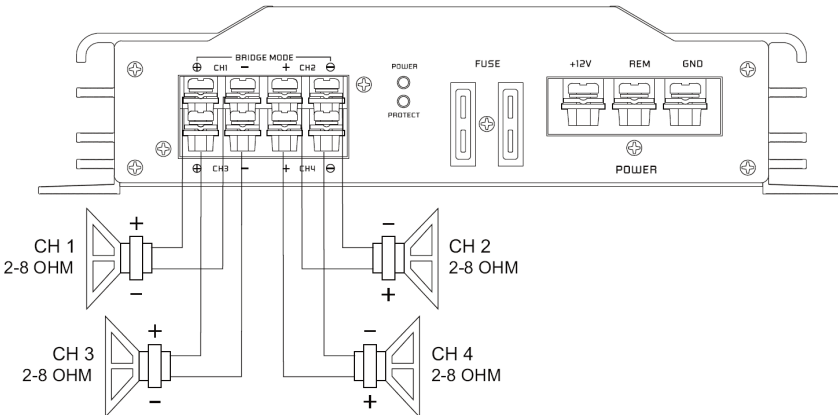

**Lautsprecher Impedanz /
 Speaker impedance / Impédance haut parleur
 2 ~ 8 Ohm**

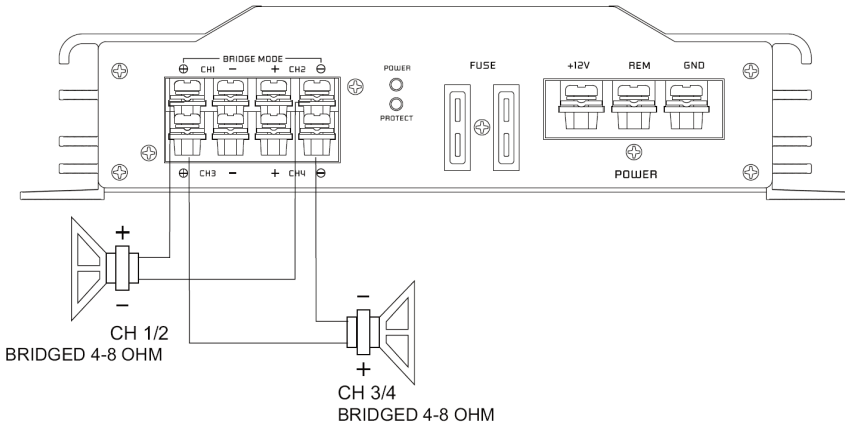

**Lautsprecher Impedanz /
Speaker impedance / Impédance haut parleur
4 ~ 8 Ohm**

Trimode käyttö – GZIA 4115HPX-B

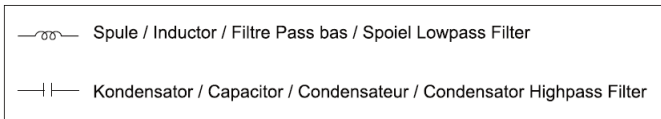
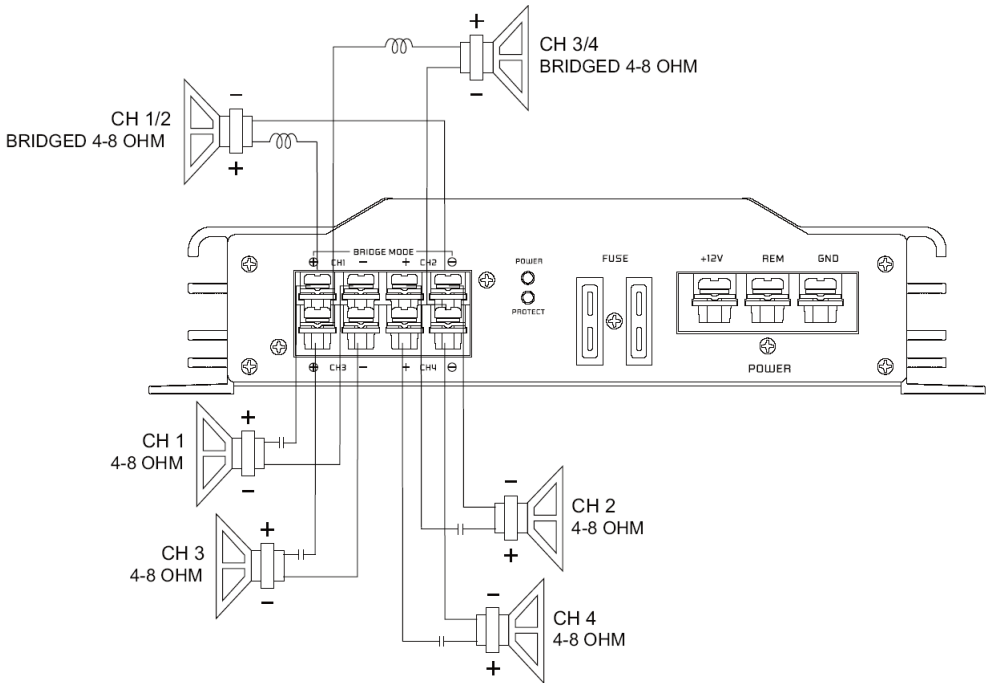

**Lautsprecher Impedanz /
Speaker impedance / Impédance haut parleur
4 ~ 8 Ohm**

Tekniset tiedot

Malli	GZIA 1.300HPX-B	GZIA 1.600HPX-B
Tyyppi	1 Channel Class A/B	1 Channel Class A/B
RMS teho @ 4 Ω CEA Standard CEA-2006-A	1 x 200 W (1% THD+N)	1 x 230 W (1% THD+N)
RMS teho @ 2 Ω CEA Standard CEA-2006-A	-	1 x 400 W (1% THD+N)
RMS teho @ 1 Ω CEA Standard CEA-2006-A	-	1 x 600 W (1% THD+N)
MAX teho CEA Standard CEA-2006-A	1 x 300 W @ 4 Ω (10% THD+N)	1 x 700 W @ 1 Ω (10% THD+N)
Vaimennuskerroin	> 150	> 150
Häiriötäisyys	> 80 dB	> 80 dB
Alipäästösuodin	30 – 250 Hz	30 – 250 Hz
Bass Boost	0 – 12 dB	0 – 12 dB
Ylipäästösuodin	-	-
Taajuusvaste	10 Hz – 250 Hz	10 Hz – 30 KHz
Sisääntulonherkkyys	200 mV – 6 V	200 mV – 6 V
Bassonkukkosäädin	✓	✓
Auto-On @ High level	✓	✓
Sulake	1 x 30A	2 x 30A
Mitat W x H x L mm	200 x 213 x 50	333 x 213 x 50
Mitat W x H x L tuumaa	8.39" x 8.39" x 1.97"	13.11" x 8.39" x 1.97"

Tekniset tiedot

Malli	GZIA 2080HPX-B	GZIA 2130HPX-B	GZIA 2235HPX-B	GZIA 4115HPX-B
Tyyppi	2 Channel Class A/B	2 Channel Class A/B	2 Channel Class A/B	4 Channel Class A/B
RMS teho @ 4 Ω CEA Standard CEA-2006-A	2 x 60 W (1% THD+N)	2 x 85 W (1% THD+N)	2 x 150 W (1% THD+N)	4 x 70 W (1% THD+N)
RMS teho @ 2 Ω CEA Standard CEA-2006-A	2 x 80 W (1% THD+N)	2 x 130 W (1% THD+N)	2 x 235 W (1% THD+N)	4 x 115 W (1% THD+N)
RMS teho @ 1 Ω CEA Standard CEA-2006-A	-	-	-	-
RMS teho @ 4Ω Bridged CEA Standard CEA-2006-A	1 x 200 W (1% THD+N) 1 x 240 W (10% THD+N)	1 x 260 W (1% THD+N) 1 x 320 W (10% THD+N)	1 x 470 W (1% THD+N) 1 x 540 W (10% THD+N)	2 x 230 W (1% THD+N) 2 x 250 W (10% THD+N)
Vaimennuskerroin	> 150	> 150	> 100	> 100
Häiriöetäisyys	> 85 dB	> 85 dB	> 80 dB	> 80 dB
Alipäästösuodin	30 – 250 Hz	30 – 250 Hz	30 – 250 Hz	30 – 250 Hz
Ylipäästösuodin	40 – 3000 Hz	40 – 3000 Hz	40 – 3000 Hz	40 – 3000 Hz
Taajuusvaste	10 Hz – 30 KHz	10 Hz – 30 KHz	10 Hz – 30 KHz	10 Hz – 30 KHz
Sisääntulonherkkyyks	200 mV – 6 V	200 mV – 6 V	200 mV – 6 V	200 mV – 6 V
Bassonkukkosäädin	-	✓ (optional)	✓	-
Auto-On @ High level	✓	✓	✓	✓
Sulake	1 x 20A	2 x 15A	2 x 25A	2 x 25A
Mitat W x H x L mm	175 x 213 x 50	215 x 213 x 50	285 x 213 x 50	285 x 213 x 50
Mitat W x H x L tuumaa	6.89" x 8.39" x 1.97"	8.46" x 8.39" x 1.97"	11.22" x 8.39" x 1.97"	11.22" x 8.39" x 1.97"

Ongelman esiintyessä

Ongelman kuvaus	Tarkasta	Toimenpide
Ei ääntä	Palaako POWER LED valo?	Tarkasta vahvistimen sulakkeet. Tarkasta onko herätevirtajohto kytketty. Tarkista signaalikaapelit. Tarkasta kytkimen asennot. Tarkasta ohjelmälähteen äänenvoimakkuussäätimen asento.
	Palaako diagnostiikka LED valo?	Tarkasta etteivät kaiutinjohdot ole oikosulussa tai vahvistin ylikuumentunut.
Vahvistin ei käynnisty	Tuleeko vahvistimelle virta?	Tarkasta virtajohto
	Tuleeko vahvistimelle herätevirta?	Tarkasta ohjelmälähteen kytkennät.
Ei ääntä yksittäisestä kaiutinlähdestä	Onko vikaa kaiutinjohdotuksessa?	Tarkasta että kaiutinjohdot ovat kytketty ja että ne eivät ole oikosulussa.
	Onko vikaa signaalikaapeleissa?	Käännä vasen ja oikea RCA johto selvittääksesi onko vika ennen vahvistinta.
Vahvistin kytketty pois päältä keskimääräisellä / kovalla voimakkuudella	Onko väärä kaiutinkuorman impedanssi?	Varmistu että kaiutinkuorman impedanssi on suositellun kaltainen.
Protection LED palaa	Onko vahvistin ylikuumentunut?	Vähennä äänenvoimakkuutta
	Onko kaiutinjohdot oikosulussa?	Tarkasta kaiutinjohtojen kytkennät ja eristeet

Die Gewährleistung entspricht der gesetzlichen Regelung. Eine Rücksendung kann nur nach vorheriger Absprache und in der Originalverpackung erfolgen. Bitte unbedingt einen maschinell erstellten Kaufbeleg und eine Fehlerbeschreibung beilegen. Von der Gewährleistung ausgeschlossen sind Defekte, die durch Überlastung, unsachgemäße Behandlung oder bei Teilnahme an Wettbewerben entstanden sind. Wir behalten uns das Recht vor, zukünftig nötige Änderungen oder Verbesserungen an dem Produkt vorzunehmen ohne den Kunden darüber zu informieren.

Limited warranty - defective products must be returned in original packaging - please add a copy of the original purchasing invoice showing the purchasing date and a detailed description of the failure. Failure caused by overload, misuse or by using the product for competition purpose are not covered by the warranty. We reserve the right to make needed change or improvement to the product without informing customer about this in advance.

De Garantie bepalingen van alle door ground zero geleverde producten is volgens wettelijke bepalingen geregeld. Een retourzending kan alleen na duidelijke afspraak en in de originele verpakking plaatsvinden. SVP een aankoopbon en een duidelijke storingsomschrijving bijvoegen. Van garantie uitgesloten zijn defecten door overbelasting, onkundig gebruik, of door deelname aan wedstrijden (SPL) ontstaan zijn. Wij behouden ons het recht om de nodige veranderingen of verbeteringen aan het product door te voeren zonder de klant hierover te informeren.

La garantie est conforme aux droits légaux. Un retour du produit défectueux doit être dans son emballage d'origine sur présentation du reçu ou de la facture indiquant la description du défaut. La présente Garantie n'est pas applicable lorsque le produit a été endommagé en raison: Mauvaise alimentation, Trop de puissance (HP, Subwoofer) Accident, Installation ou Utilisation non conforme aux normes Technique (Concours SPL etc). Nous nous réservons le droit d'entreprendre à l'avenir nécessairement des modifications ou des améliorations au produit sans informer le client.

Ground Zero GmbH

Erlenweg 25, 85658 Egming, Germany

Tel. +49 (0)8095/873 830 Fax -8310

www.ground-zero-audio.com



GROUND ZERO®

GERMAN ENGINEERING

IRIDIUM-SERIES AMPLIFICADOR

MANUAL DE USUARIO

GZIA 1.300HPX-B

GZIA 1.600HPX-B

GZIA 2080HPX-B

GZIA 2130HPX-B

GZIA 2235HPX-B

GZIA 4115HPX-B

Features

- 4 Ohm / 2 Ohm stable Stereo
- 4 Ohm stable Mono (GZIA 1.300HPX-B)
- 1 Ohm stable Mono (GZIA 1.600HPX-B)
- Power & Indicador de proteccion
- Bass Boost (GZIA 1.300HPX-B / 1.600HPX-B)
- Variable highpass (GZIA 2080HPX-B / 2235HPX-B / 2130HPX-B / 4115HPX-B)
- Variable lowpass
- Auto encendido por entrada de alta (hi level in)
- Sensibilidad de entrada ajustable
- Soft delayed remote turn- on
- Potenciómetro externo de sub (GZIA 1.300HPX-B / 1.600HPX-B / 2235HPX-B / GZIA 2130HPX-B opcional)
- Protección : térmica, de corte y de sobrecarga

Herramientas y material necesario

- Destornillador
- Taladro eléctrico, 3 mm / 0.12" carbide drill bit
- Tornillos
- Cable de alimentación min. 10 mm² / 7 AWG
- Cable de masa min. 10 mm² / 7 AWG
- Cable altavoz min. 2 x 1,5 mm² / 15 AWG

Aviso!

- Como medida de precaución es recomendable desconectar la batería del vehículo antes de realizar la conexión a las + 12 voltios (véase el manual de su coche para más información de) cableado de alimentación.
- Utilice precaución el tronco de perforación. Sus líneas de freno y el tanque de gas pueden ser dañados por perforar con su broca, esto podría ocasionar daños o el fracaso de los sistemas operativos de coches.
- Nunca pasar cables ángulos agudos. Se recomienda a la fuente de alimentación del amplificador con un mínimo de condensador de 1 faradio para garantizar un voltaje de funcionamiento estable.

WARNING !

Sistemas audio de alta potencia en un vehículo son capaces de generar los niveles de presión acústica "Live Concert". La continua exposición a niveles de sonido excesivamente alto volumen puede causar pérdida de la audición o daños. También, la operación de un vehículo de motor mientras escucha a equipos de audio en los niveles de volumen alto puede afectar su capacidad de escuchar sonidos externos tales como bocinas, señales de advertencia o vehículos de emergencia, constituyendo así un potencial riesgo de tráfico. En interés de la seguridad, electrónica de consumo recomienda escuchar a niveles más bajos de volumen durante la conducción.

Planificando el sistema

Antes de comenzar la instalación, considere lo siguiente:

- a. Si va a ampliar el sistema mediante la adición de otros componentes en el futuro, garantizar que quede espacio adecuado, y cumplen con los requisitos de ventilación.
- b. Si el aparato de radio / origen está equipado con salidas pre-amp, es posible utilizarlas para impulsar el amplificador y conexión (amplificador) a los altavoces traseros 2.

Montando el amplificador

- a. Seleccione una ubicación adecuada que es conveniente para el montaje, es accesible para el cableado y tiene amplio espacio para la circulación de aire y refrigeración.
- b. Utilice el amplificador como una plantilla para marcar los agujeros de montaje, quitar el amplificador.

Aviso

A – Elegir una posición de montaje donde estén protegidos todos los cables eléctricos se dañe por bordes filidos, calor u otras condiciones. + Conexiones eléctricas de 12 voltios DC deben tener fusibles en el lado de la batería. Asegúrese de que su radio y todos los demás dispositivos se desactivará mientras la conexión de su sistema.

B - Si necesita reemplazar el fusible de potencia cámbielo sólo con un fusible idéntico a la acompaña al sistema. Utilizando un fusible de tipo diferente o calificación puede ocasionar daños a este sistema que no está cubierto por la garantía.

Controles y funciones – GZ1A 1.300HPX-B

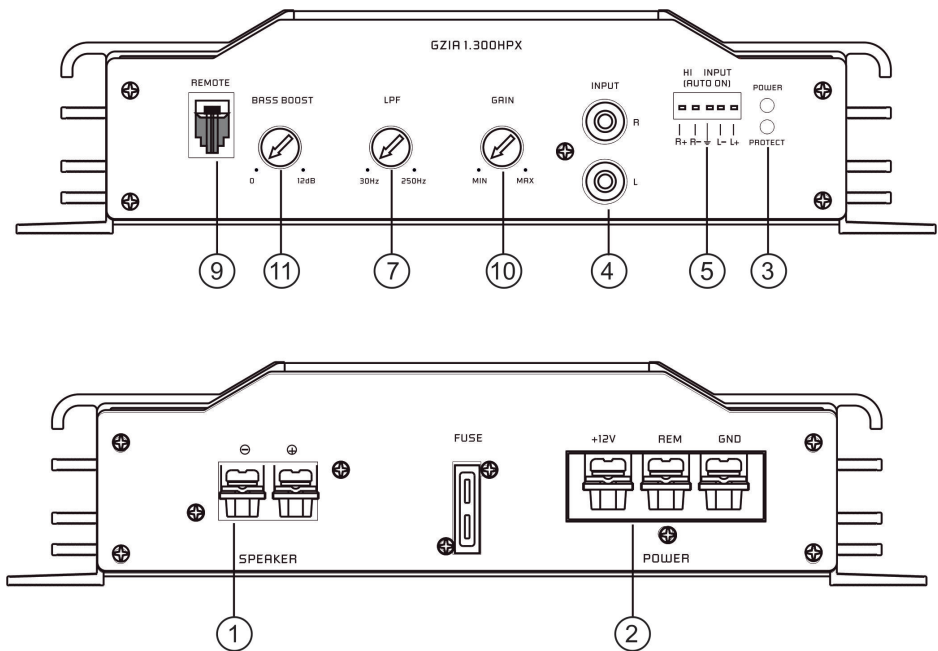

Controles y funciones – GZIA 1.600HPX-B

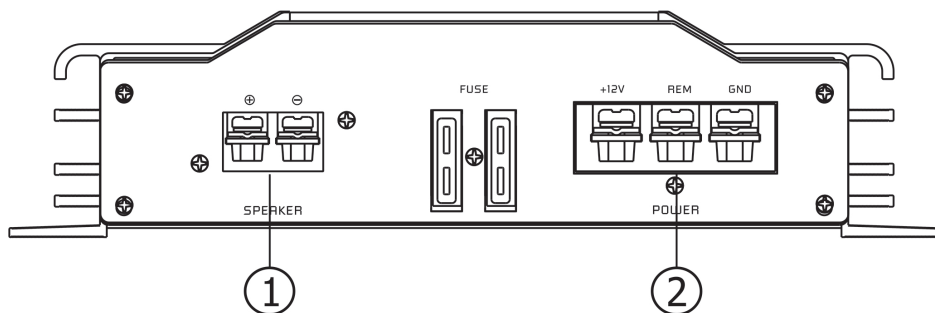
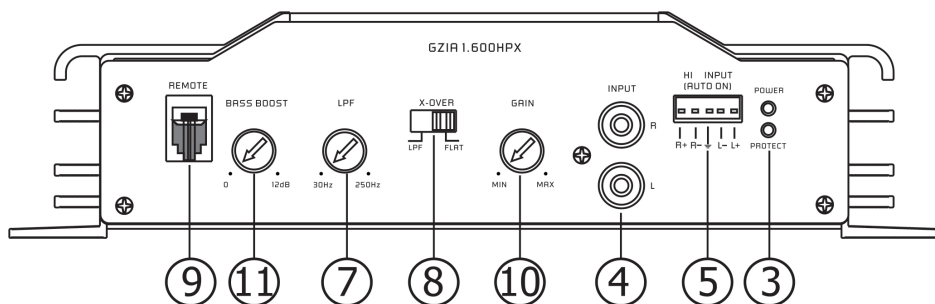

Controles y funciones – GZIA 2080HPX-B

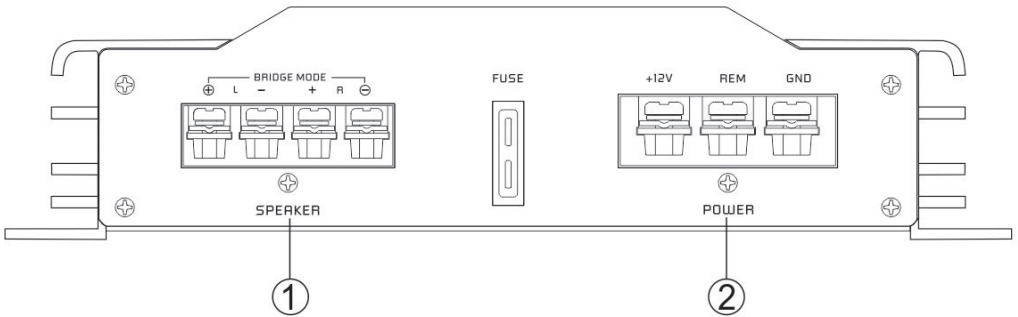
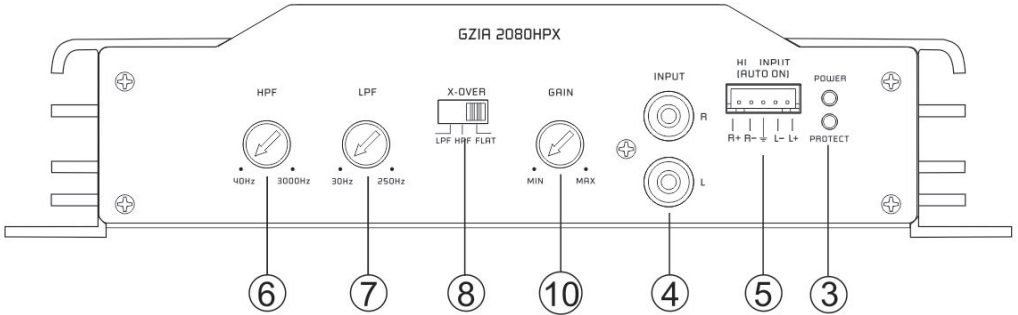

Controles y funciones – GZ1A 2130HPX-B

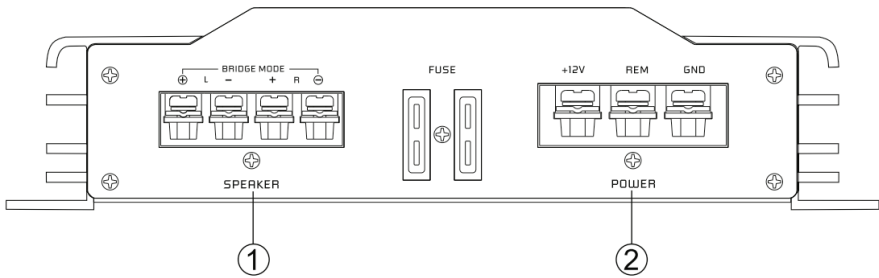
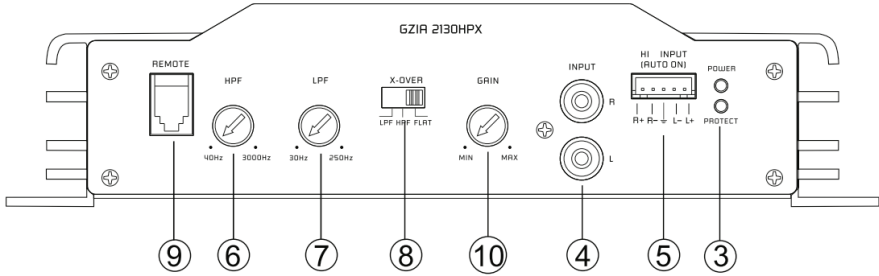

Controles y funciones – GZIA 2235HPX-B

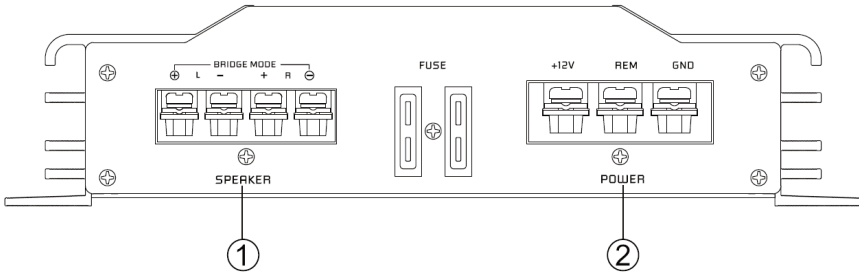
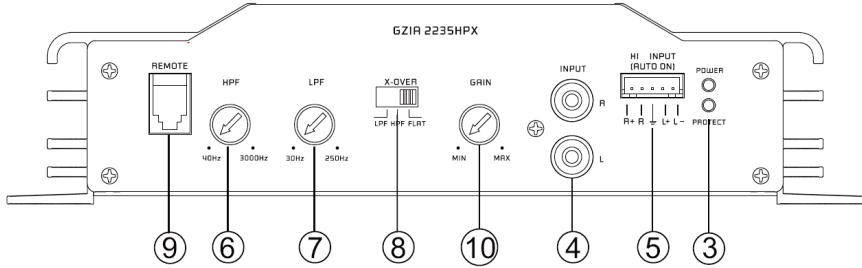

Controles and functions – GZIA 4115HPX-B

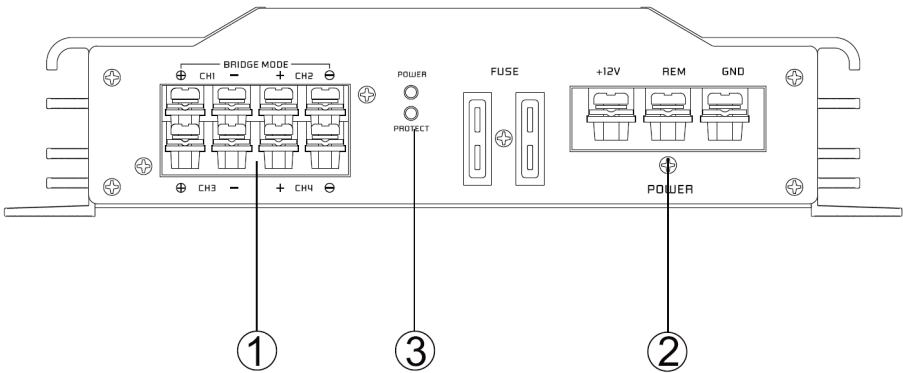
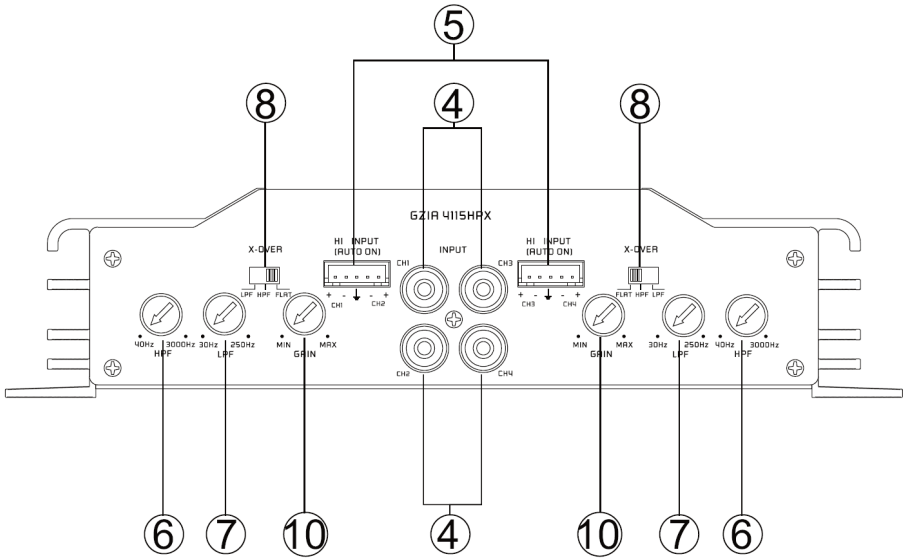

Controles y funciones

1	Terminales altavoz	Para conectar a los altavoces
2	Terminales de corriente	GND -> Conectara a masa (chapa del coche) REM -> Remote de antena de radiol [No usar con entrada de alta (5)] BATT -> +12 Volt
3	Indicador de status	VERDE – OK ROJO – Error
4	RCA inputs	Terminalpar conectar los cables de RCA . Para evitar fallos, ppor favor use cables RCA de calidad. IMPORTANTE! No usar cables de RCA si se tienen entradas de alta conectadas, puede dañar su sistema. Usar una u otra entrada
5	High Level inputs	Son para usarlas con Fuentes originals que no dispongan de de salidas de RCA. Conectar esta entrada a las salidas de altavoces de la radio. El amplificador automáticamente se encenderá tan pronto como la señal se reciva (Auto On). El cable de remote no se tendrá que usar en este caso- Terminal (2). IMPORTANTI No usar cables de RCA si se tienen entradas de alta conectadas, puede dañar su sistema. Usar una u otra entrada
6	High Pass controller	Ajuste el interruptor a la posicion „HIGH” . Ajuste la frecuencia variable del crossover HPF a la frecuencia deseada usando el potenciómetro. Todas las frecuencias a partir de 40 y3000 Hz pueden ser reproducidas.
7	Low Pass controller	Solo las frecuencias desde 30Hz a 250Hz seran reproducidas (dependiendo de la posición del filtro LPF). Coloque el interruptor ala posición „LOW” . Ajuste la frecuencia variable donde desee usando el potenciómetro.
8	Mode switch	Ajuste el crossover para escojer la utilizacion. LPF – Solo frecuencias bajas (entre 30Hz - 250Hz) seran reproducidas. FLAT – Todas las frecuencias seran reproducidas. HPF – Solo medio-altas frecuencias (sobre 40Hz – 3000Hz) serasn reproducidas.
9	Remote control input	Para conectar el potenciómetro remote de sub (GZIA 2130HPX/ 2235HPX/ 1.600HPX)
10	Input level controller	Con este potenciómetro puede regular la sensibilidad de entrada.
11	Bass Boost controller	Para poder ajustar los graves en 45hz desde 0- 12db

High Level Input- Entrada de alta (altavoces)

Dependiendo de la configuracion de tu coche y sistema de sonido ruidos o parasites pueden aparecer al usar la entrada de altas. Por favor usar el cable adicional del medio a masa para reducir posibles parasites.

El funcion de auto encendido permite usar el amplificador sin necesidad de usar un remote exterior. Esto hace posible operer con un sistema de radio original(OEM)y que la radio original active el sistema, siempre que estas radios no dispongan de RCA y remote.

High Level Input – GZIA 1.300HPX-B

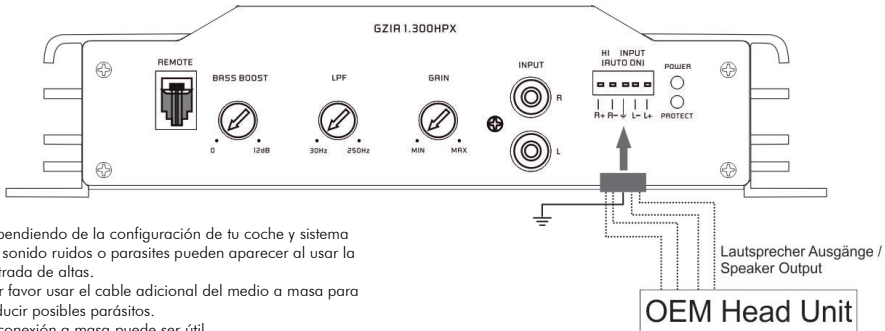

Dependiendo de la configuración de tu coche y sistema de sonido ruidos o parasitos pueden aparecer al usar la entrada de altos.
 Por favor usar el cable adicional del medio a masa para reducir posibles parasitos.
 La conexión a masa puede ser útil.

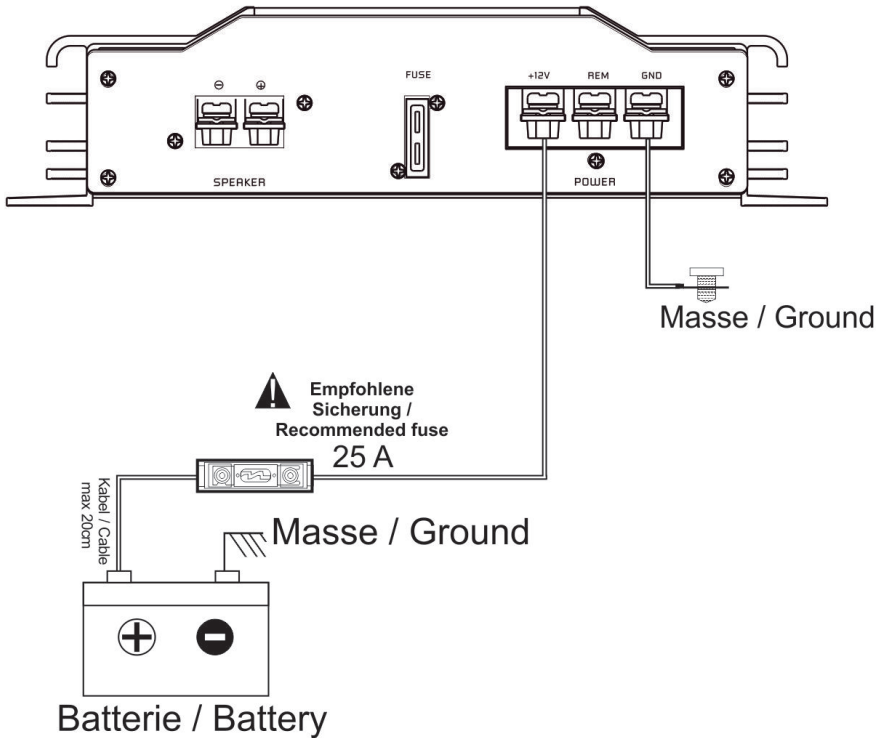

High Level Input – GZ1A 1.600HPX-B

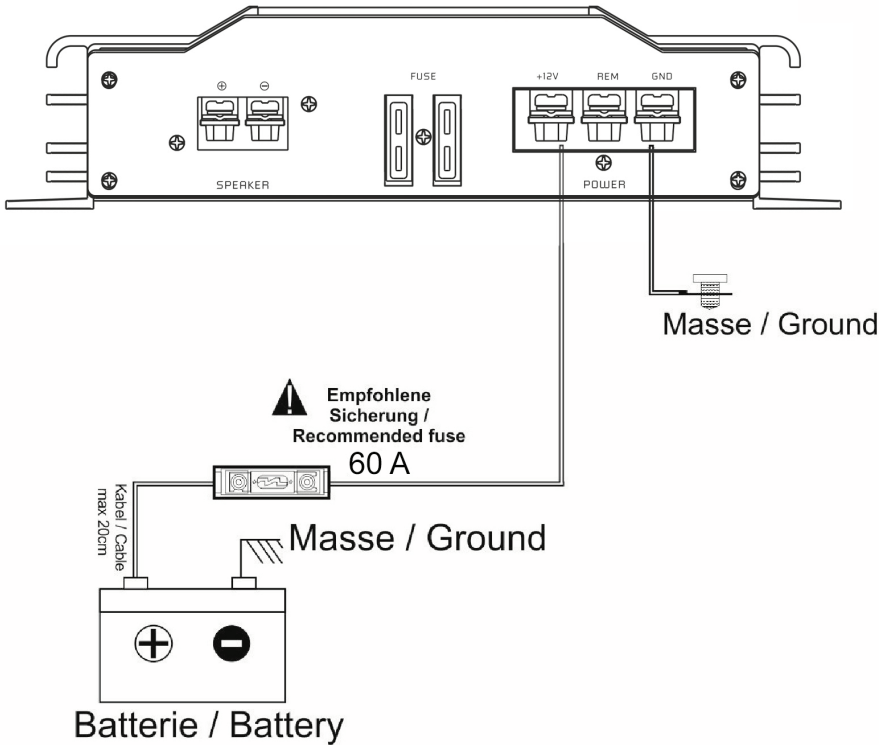
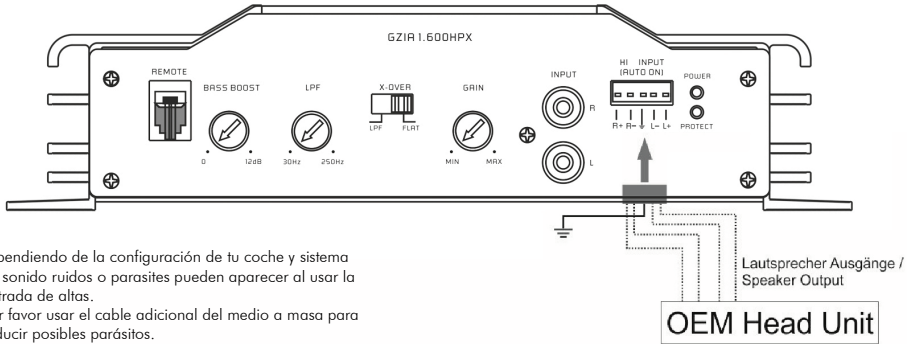

High Level Input – GZIA 2080HPX-B

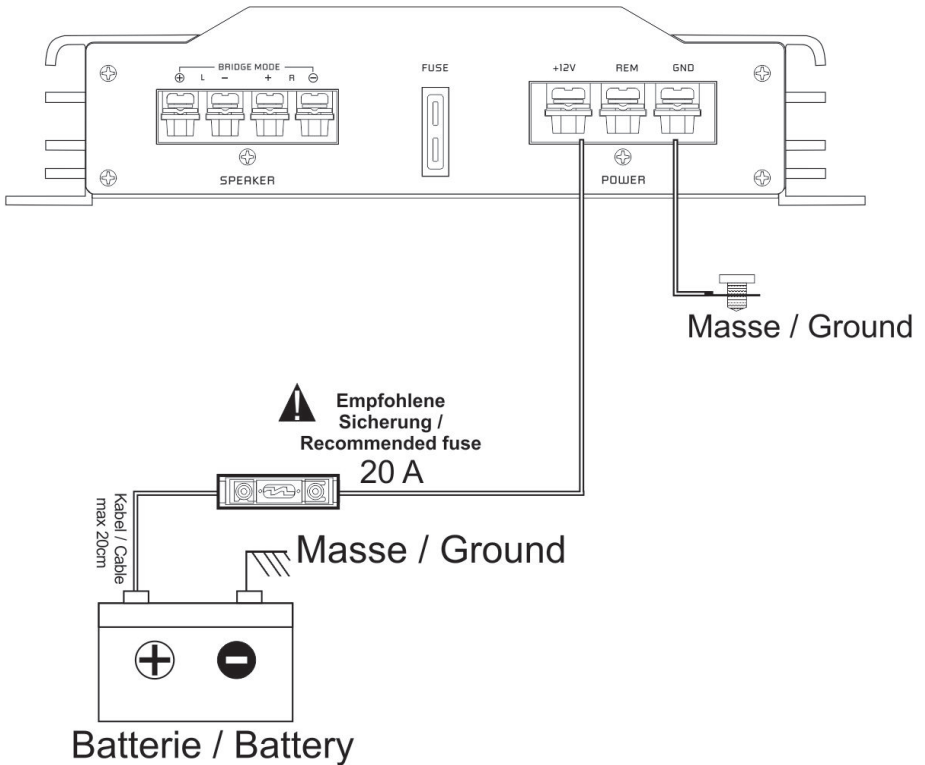
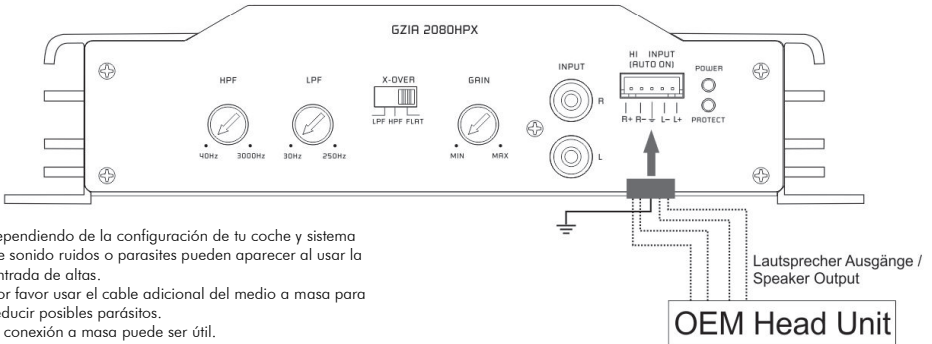

High Level Input – GZIA 2130HPX-B

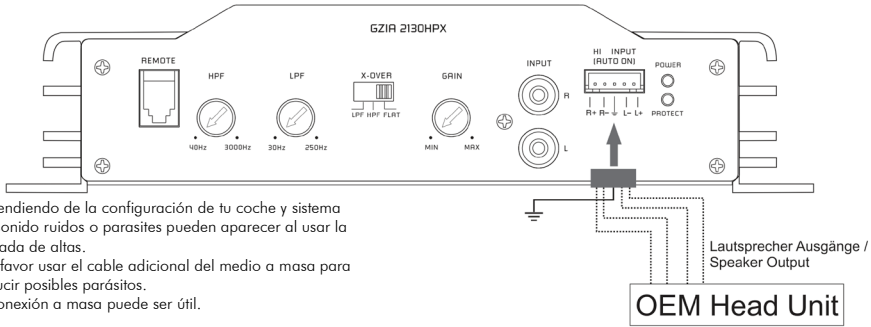

Dependiendo de la configuración de tu coche y sistema de sonido ruidos o parasites pueden aparecer al usar la entrada de altas.
 Por favor usar el cable adicional del medio a masa para reducir posibles parásitos.
 La conexión a masa puede ser útil.

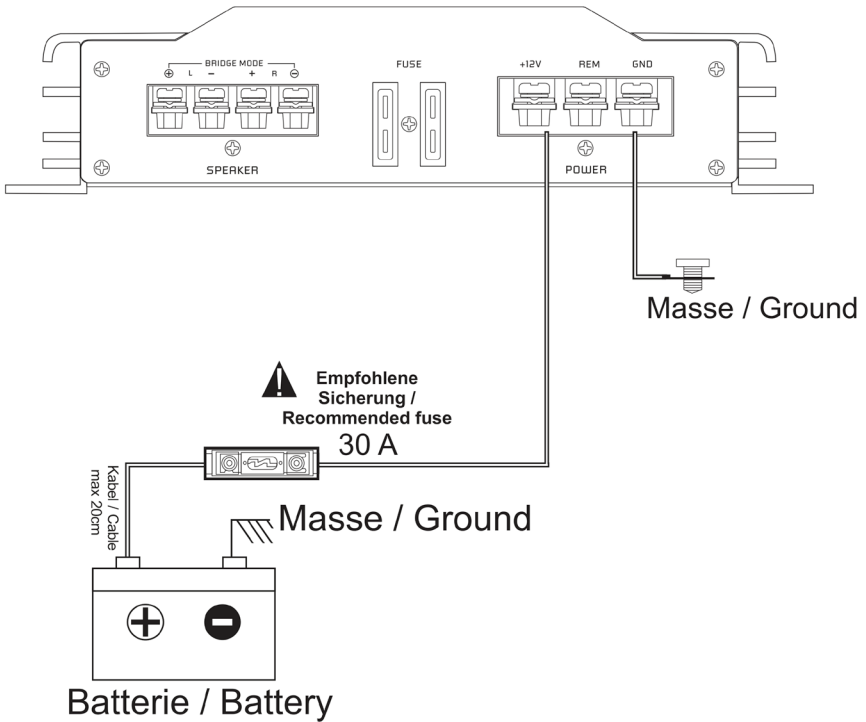

High Level Input – GZIA 2235HPX-B

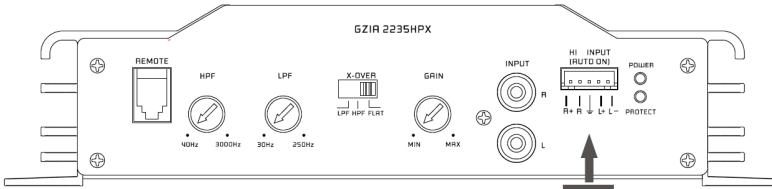

Dependiendo de la configuración de tu coche y sistema de sonido ruidos o parasites pueden aparecer al usar la entrada de altas.
 Por favor usar el cable adicional del medio a masa para reducir posibles parásitos.
 La conexión a masa puede ser útil.

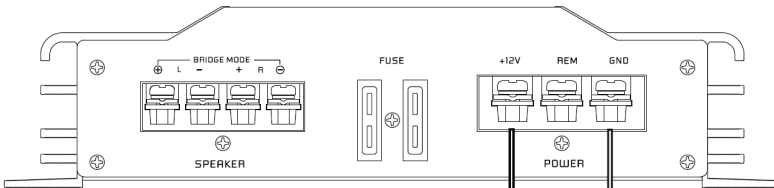

Masse / Ground

⚠ **Empfohlene
Sicherung /
Recommended fuse**
50 A

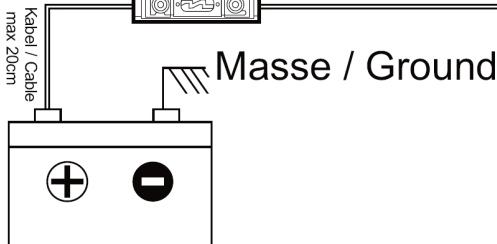

High Level Input – GZIA 4115HPX-B

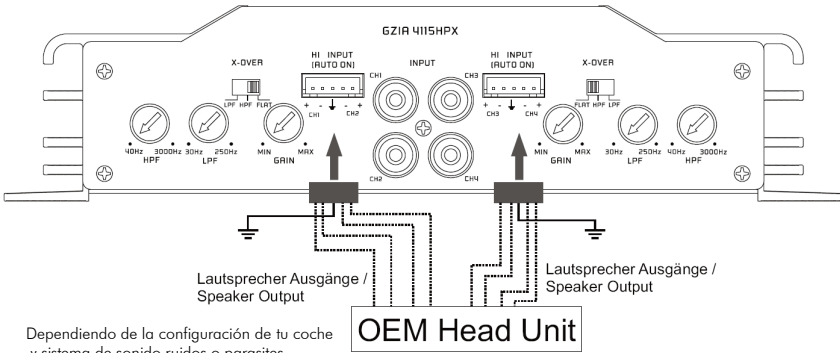

Dependiendo de la configuración de tu coche y sistema de sonido ruidos o parasites pueden aparecer al usar la entrada de altas. Por favor usar el cable adicional del medio a masa para reducir posibles parasitos. La conexión a masa puede ser útil.

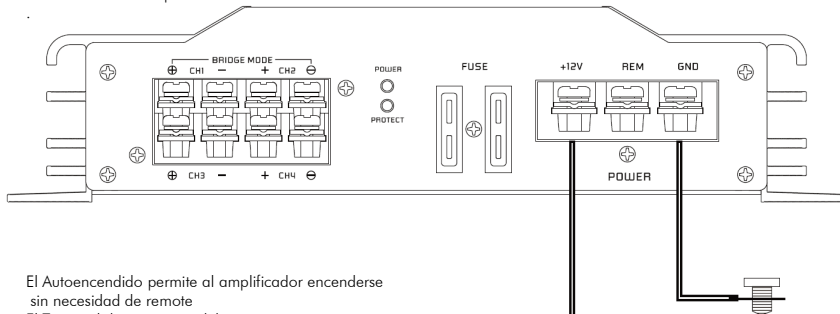

El Autoencendido permite al amplificador encenderse sin necesidad de remote
El Terminal de remote no debe conectarse

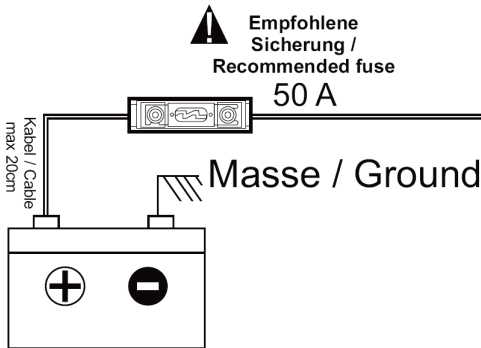

Encendido de amplificador

El amplificador se enciende automáticamente en unos segundos después de encender el aparato de radio.

Note: El amplificador temporalmente apaga si se calienta demasiado y, a continuación, reinicia automáticamente una vez se enfría (sobre los 80° / 176° F).

Ajustando el nivel de audio

1. LEVEL (Min/Max): Gire completamente contador - las agujas del reloj a MIN
2. Activar el control de volumen del sistema de sonido de la auto sobre dos tercios de su gama completa.
3. Ajustar el nivel a un nivel cómodo de escucha.

Conectar el altavoz en trimode - notas

Trimode permite un subwoofer para trabajar en modo mono mientras juegan los principales altavoces en estéreo. Deja el conmutador cruzado en posición "FULL".

Usar condensadores 100 volt, non-polar para filtro pasaltos out low frequencies and Air-core or Ferrit-core bobinas con un diámetro mínimo de 1 mm / 0.039" para el corte de paso bajo filtrar las frecuencias altas.

Los valores de condensador y bobina como están escritos en la tabla siguiente. La parte delantera y traseros canales de este amplificador obtienen esta capacidad. Sólo los canales izquierdos y derecho traseros se muestran en las siguientes imágenes.

Valores para filtro pasivo de 6dB pasivo

Frecuencia	Bobina	Condensador
80 Hz	7,5 mH	470 uF
100 Hz	6,5 mH	330 uF
120 Hz	5,5 mH	370 uF
150 Hz	4 mH	220 uF

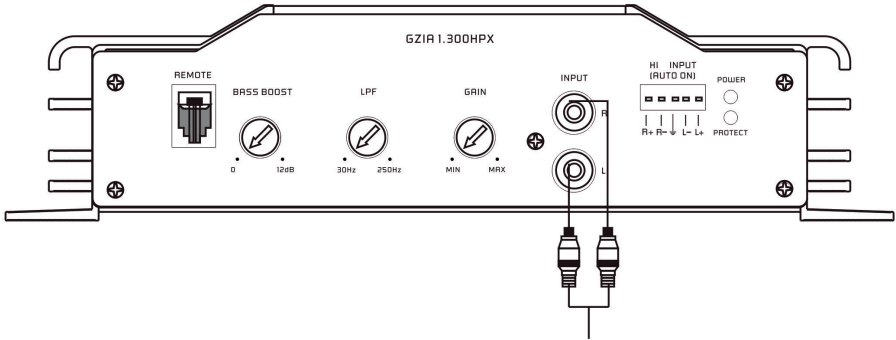

Zum Line out des Autoradios /
To car stereo line out /
Sortie stéréo de la voiture /
Naar line out radio

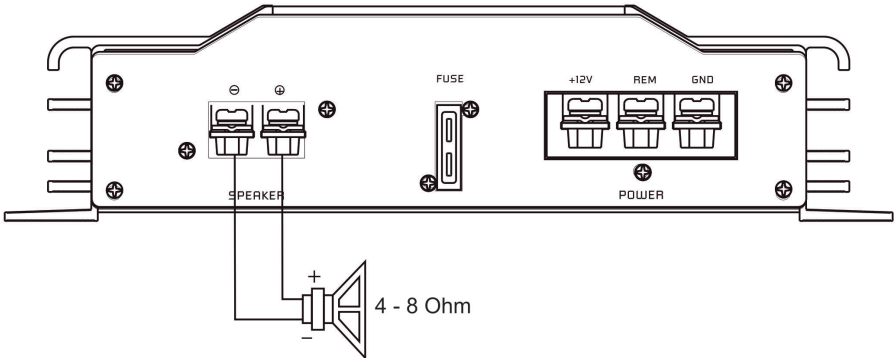

**Lautsprecher Impedanz /
Speaker impedance / Impédance haut parleur
4~8 Ohm**

Wiring – GZIR 1.600HPX-B

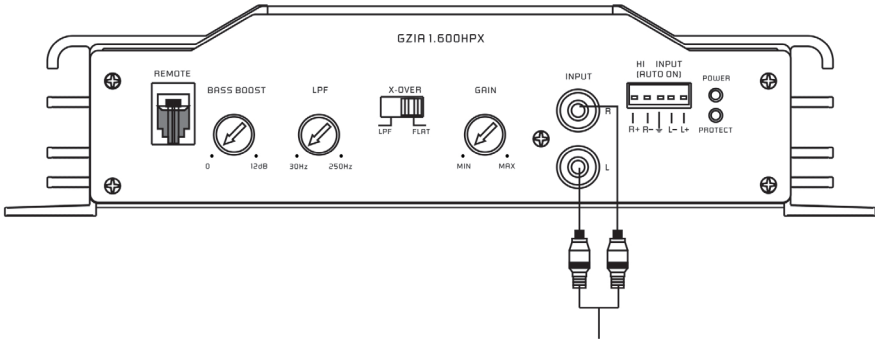

Zum Line out des Autoradios /
To car stereo line out /
Sortie stéréo de la voiture /
Naar line out radio

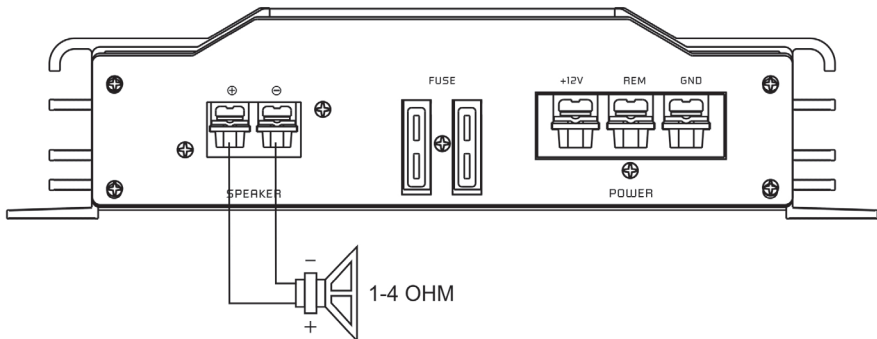

**Lautsprecher Impedanz /
Speaker impedance / Impédance haut parleur
1~4 Ohm**

Stereo wiring – GZIA 2080HPX-B

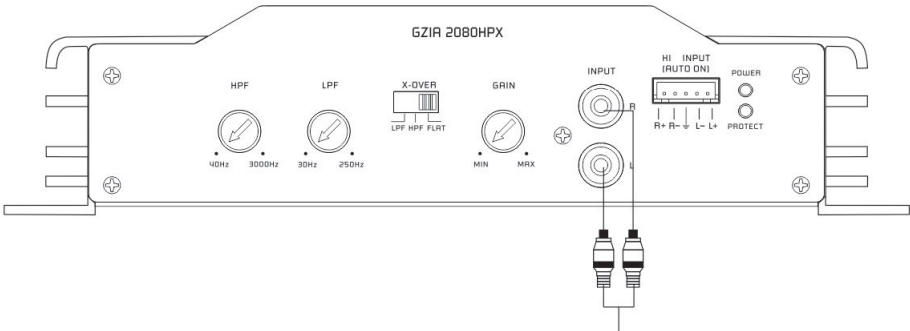

Zum Line out des Autoradios /
To car stereo line out / Sortie stéréo de la voiture /
Naar line out radio

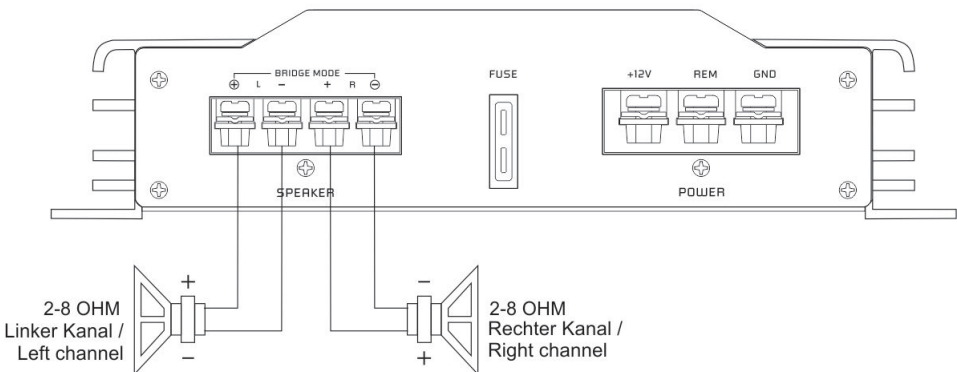

**Lautsprecher Impedanz /
Speaker impedance / Impédance haut parleur
2 ~ 8 Ohm**

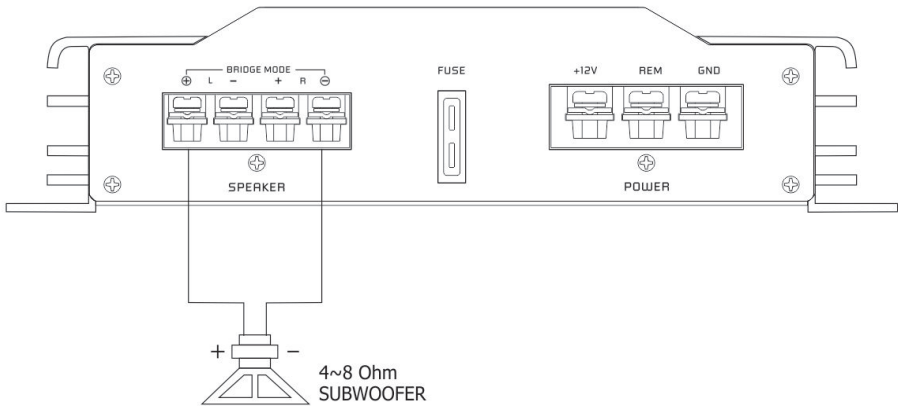

**Lautsprecher Impedanz /
Speaker impedance / Impédance haut parleur
4 ~ 8 Ohm**

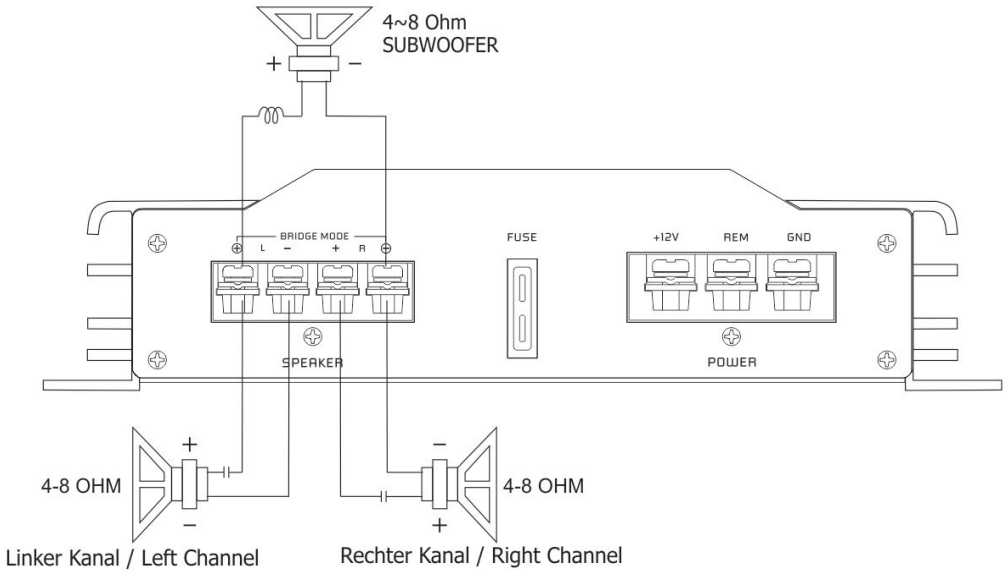

—∞— Spule / Inductor / Filtre Pass bas / Spoel Lowpass Filter

—|— Kondensator / Capacitor / Condensateur / Condensator Highpass Filter

Lautsprecher Impedanz / Speaker impedance / Impédance haut parleur 4 ~ 8 Ohm

Stereo wiring – GZIA 2130HPX-B

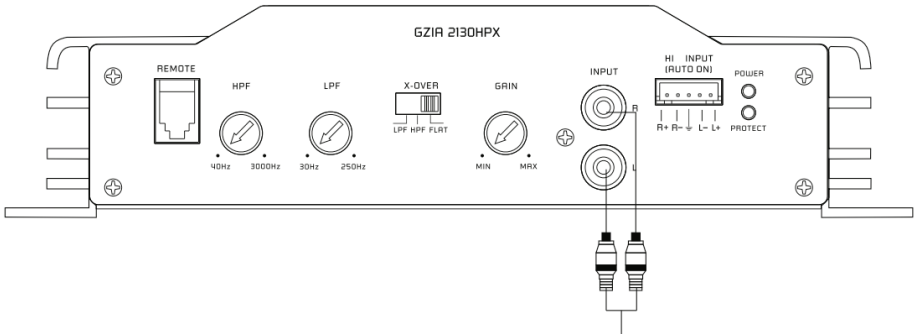

Zum Line out des Autoradios /
To car stereo line out / Sortie stéréo de la voiture /
Naar line out radio

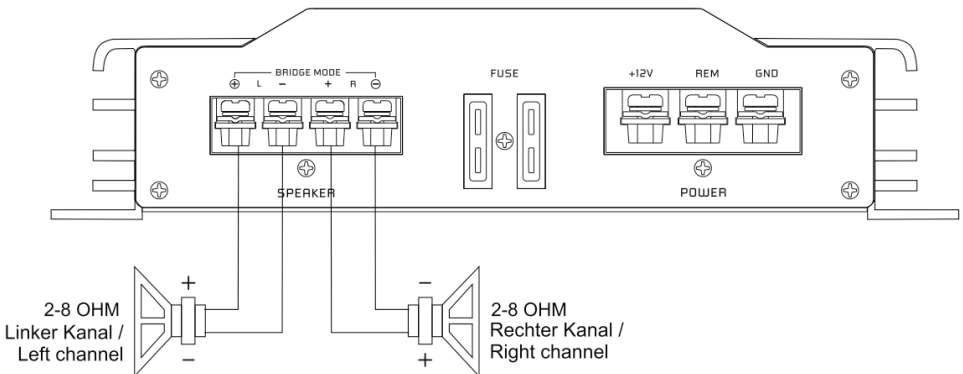

**Lautsprecher Impedanz /
Speaker impedance / Impédance haut parleur
2 ~ 8 Ohm**

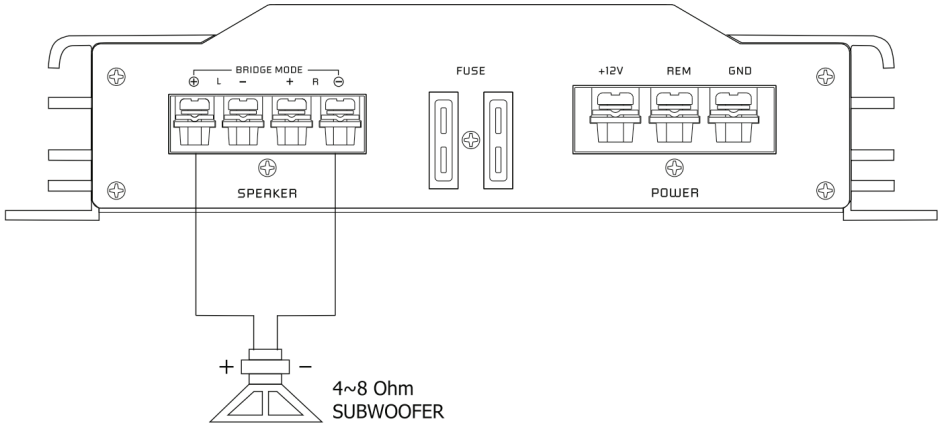

**Lautsprecher Impedanz /
Speaker impedance / Impédance haut parleur
4 ~ 8 Ohm**

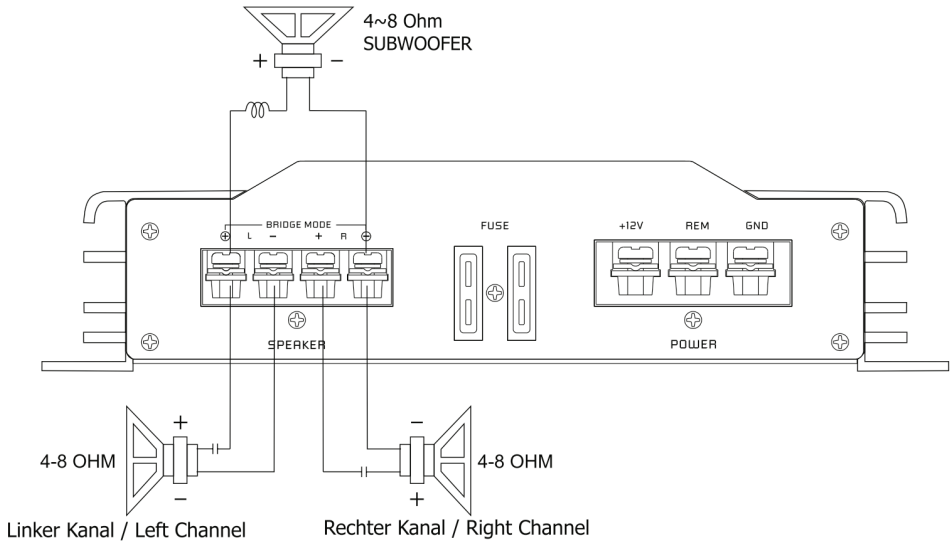

—∞— Spule / Inductor / Filtre Pass bas / Spoel Lowpass Filter

—|— Kondensator / Capacitor / Condensateur / Condensator Highpass Filter

**Lautsprecher Impedanz /
Speaker impedance / Impédance haut parleur
4 ~ 8 Ohm**

Stereo wiring – GZIA 2235HPX-B

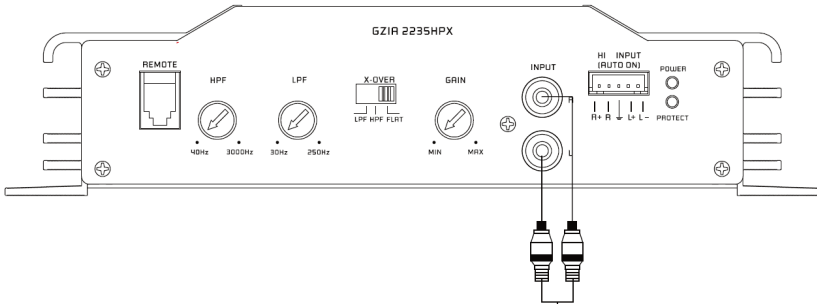

Zum Line out des Autoradios /
To car stereo line out / Sortie stéréo de la voiture /
Naar line out radio

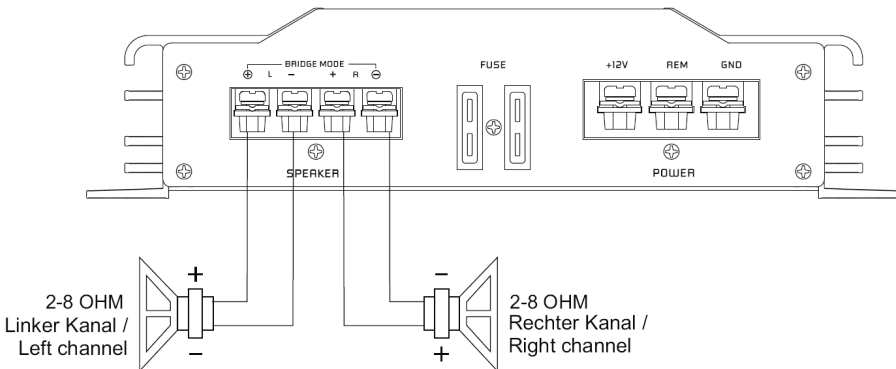

**Lautsprecher Impedanz /
Speaker impedance / Impédance haut parleur
2 ~ 8 Ohm**

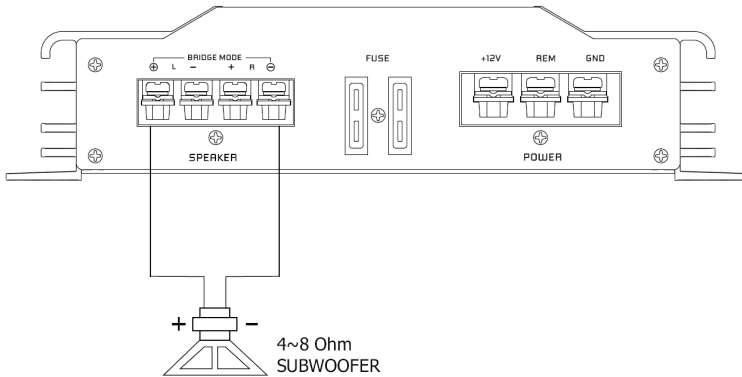

**Lautsprecher Impedanz /
Speaker impedance / Impédance haut parleur
4 ~ 8 Ohm**

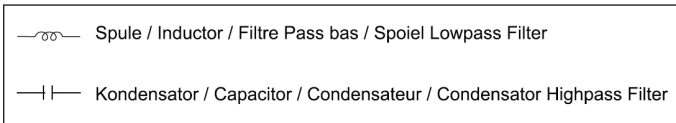
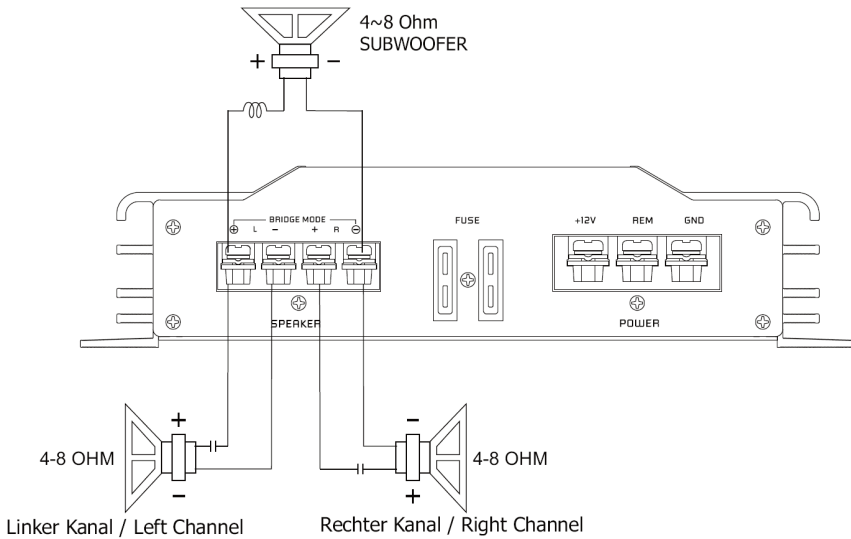

**Lautsprecher Impedanz /
Speaker impedance / Impédance haut parleur
4 ~ 8 Ohm**

Stereo wiring – GZ1A 4115HPX-B

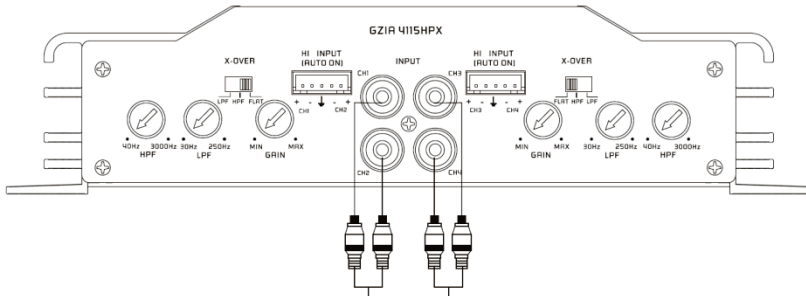

Zum Line out des Autoradios /
 To car stereo line out / Sortie stéréo de la voiture /
 Naar line out radio

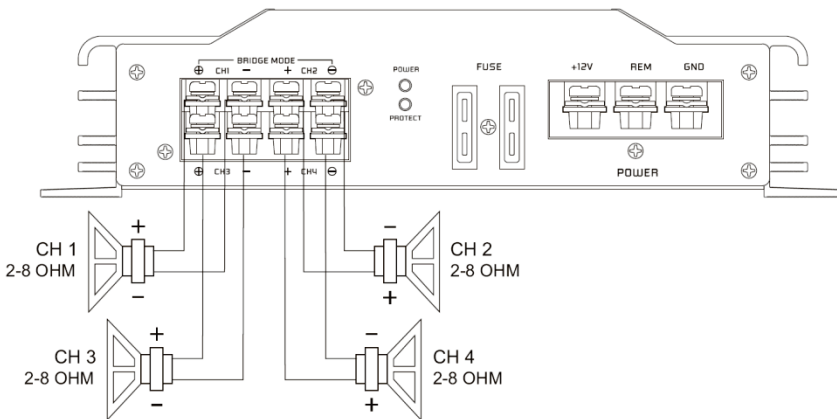

**Lautsprecher Impedanz /
 Speaker impedance / Impédance haut parleur
 2 ~ 8 Ohm**

Bridged wiring – GZIA 4115HPX-B

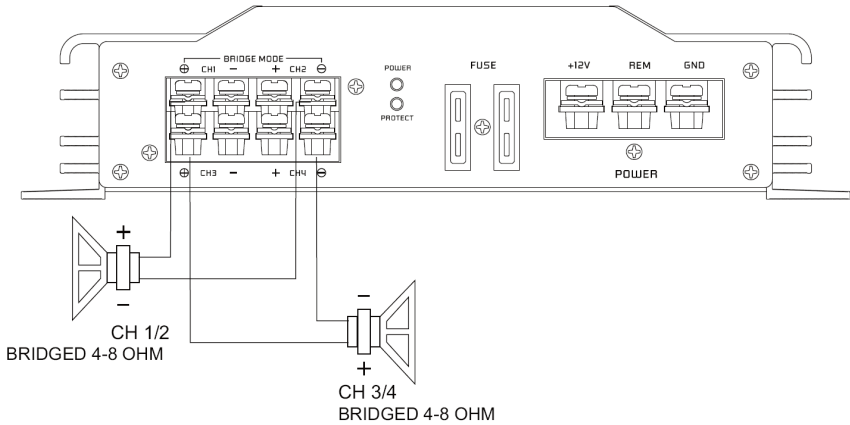

**Lautsprecher Impedanz /
Speaker impedance / Impédance haut parleur
4 ~ 8 Ohm**

Trimode operation – GZIA 4115HPX-B

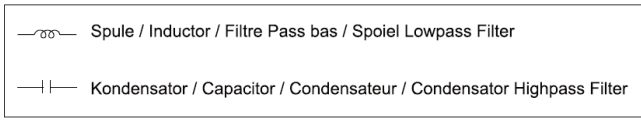
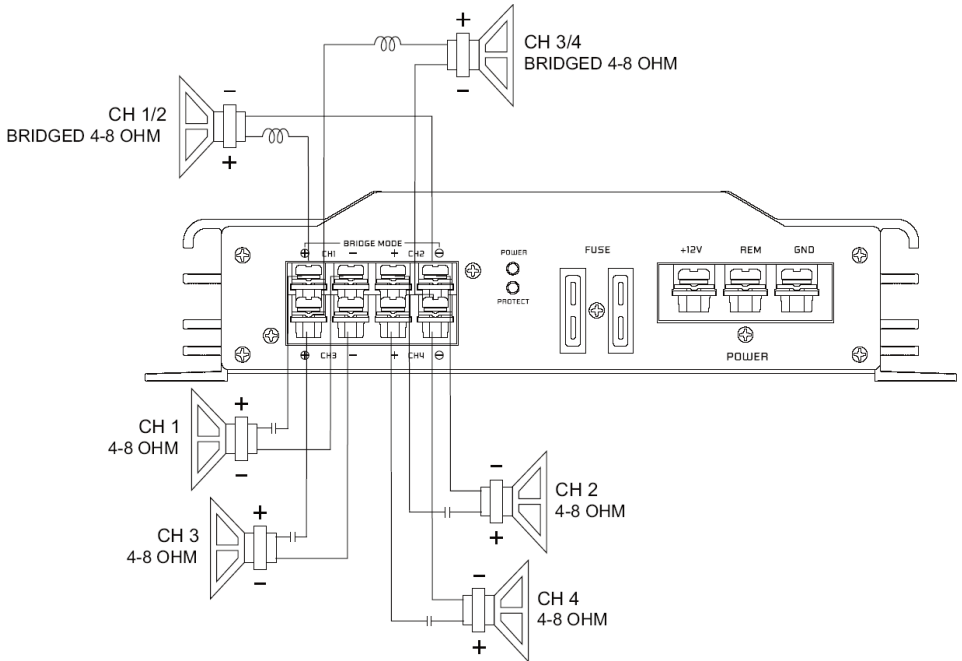

**Lautsprecher Impedanz /
Speaker impedance / Impédance haut parleur
4 ~ 8 Ohm**

Especificaciones

Modelo	GZIA 1.300HPX-B	GZIA 1.600HPX-B
Tipo	1 Canales Class A/B	1 Canales Class A/B
RMS Power @ 4 Ω CEA Standard CEA-2006-A	1 x 200 W (1% THD+N)	1 x 230 W (1% THD+N)
RMS Power @ 2 Ω CEA Standard CEA-2006-A	-	1 x 400 W (1% THD+N)
RMS Power @ 1 Ω CEA Standard CEA-2006-A	-	1 x 600 W (1% THD+N)
MAX Power CEA Standard CEA-2006-A	1 x 300 W @ 4 Ω (10% THD+N)	1 x 700 W @ 1 Ω (10% THD+N)
Damping factor	> 150	> 150
Signal to noise Ratio	> 80 dB	> 80 dB
Lowpass	30 – 250 Hz	30 – 250 Hz
Bass Boost	0 – 12 dB	0 – 12 dB
Highpass	-	-
Respuesta de frecuencia	10 Hz – 250 Hz	10 Hz – 30 KHz
Sensibilidad de entrada	200 mV – 6 V	200 mV – 6 V
Bass remote control	✓	✓
Auto-On @ High Input	✓	✓
Fusible	1 x 30A	2 x 30A
Dimensiones W x H x L mm	200 x 213 x 50	333 x 213 x 50
Dimensiones W x H x L inch	8.39" x 8.39" x 1.97"	13.11" x 8.39" x 1.97"

Especificaciones

Modelo	GZIA 2080HPX-B	GZIA 2130HPX-B	GZIA 2235HPX-B	GZIA 4115HPX-B
Tipo	2 Canales Class A/B	2 Canales Class A/B	2 Canales Class A/B	4 Canales Class A/B
RMS Power @ 4 Ω CEA Standard CEA-2006-A	2 x 60 W (1% THD+N)	2 x 85 W (1% THD+N)	2 x 150 W (1% THD+N)	4 x 70 W (1% THD+N)
RMS Power @ 2 Ω CEA Standard CEA-2006-A	2 x 80 W (1% THD+N)	2 x 130 W (1% THD+N)	2 x 235 W (1% THD+N)	4 x 115 W (1% THD+N)
RMS Power @ 1 Ω CEA Standard CEA-2006-A	-	-	-	-
RMS Power @ 4Ω Bridged CEA Standard CEA-2006-A	1 x 200 W (1% THD+N) 1 x 240 W (10% THD+N)	1 x 260 W (1% THD+N) 1 x 320 W (10% THD+N)	1 x 470 W (1% THD+N) 1 x 540 W (10% THD+N)	2 x 230 W (1% THD+N) 2 x 250 W (10% THD+N)
Damping factor	> 150	> 150	> 100	> 100
Signal to noise Ratio	> 85 dB	> 85 dB	> 80 dB	> 80 dB
Lowpass	30 – 250 Hz	30 – 250 Hz	30 – 250 Hz	30 – 250 Hz
Highpass	40 – 3000 Hz	40 – 3000 Hz	40 – 3000 Hz	40 – 3000 Hz
Respuesta de frecuencia	10 Hz – 30 KHz	10 Hz – 30 KHz	10 Hz – 30 KHz	10 Hz – 30 KHz
Sensibilidad de entrada	200 mV – 6 V	200 mV – 6 V	200 mV – 6 V	200 mV – 6 V
Bass remote control	-	✓ (opcional)	✓	-
Auto-On @ High Input	✓	✓	✓	✓
Fusible	1 x 20A	2 x 15A	2 x 25A	2 x 25A
Dimensiones W x H x L mm	175 x 213 x 50	215 x 213 x 50	285 x 213 x 50	285 x 213 x 50
Dimensiones W x H x L inch	6.89" x 8.39" x 1.97"	8.46" x 8.39" x 1.97"	11.22" x 8.39" x 1.97"	11.22" x 8.39" x 1.97"

Guía de posibles problemas

Sintomas	comprobar	Solución
No suena	Se ilumina el led de POWER?	Comprobar los fusibles del amplificador. Asegurar que remote este conectado. Comprobar los RCA. Comprobar potenciómetros. Comprobar volumen de la radio.
	Se enciende el LED de diagnóstico?	Verificación cruce en altavoz o sobrecalentamiento amplificador
Amplif no enciende	No llega corriente al amplificador	Compruebe el cable de alimentación o conexiones
	Ningún corriente al cable remoto con receptor encendido	Comprobar los cables de la radio
No hay sonido en un canal	Revisar los cables de altavoz	Inspeccionar para corto circuito o una conexión abierta
	Comprobar cables de audio	Invertir entradas RCA de izquierda y derecha para determinar si es que se produzca antes de la amp
Amp Si se desactiva en medio / alto volumen	Compruebe la impedancia de carga de altavoz	Asegúrese de que se observan las recomendaciones de impedancia de carga de altavoz correcto (si se utiliza un medidor de ohm para comprobar la resistencia de altavoz, recuerde que la resistencia DC y impedancia AC no puede ser el mismo).
Protección de LED está activada	Temperature baja	Baje el volumen de la radio
	Cables de altavoz en cortocircuito	Separar los cables de altavoces y aislar

Die Gewährleistung entspricht der gesetzlichen Regelung. Eine Rücksendung kann nur nach vorheriger Absprache und in der Originalverpackung erfolgen. Bitte unbedingt einen maschinell erstellten Kaufbeleg und eine Fehlerbeschreibung beilegen. Von der Gewährleistung ausgeschlossen sind Defekte, die durch Überlastung, unsachgemäße Behandlung oder bei Teilnahme an Wettbewerben entstanden sind. Wir behalten uns das Recht vor, zukünftig nötige Änderungen oder Verbesserungen an dem Produkt vorzunehmen ohne den Kunden darüber zu informieren.

Limited warranty - defective products must be returned in original packaging - please add a copy of the original purchasing invoice showing the purchasing date and a detailed description of the failure. Failure caused by overload, misuse or by using the product for competition purpose are not covered by the warranty. We reserve the right to make needed change or improvement to the product without informing customer about this in advance.

De Garantie bepalingen van alle door ground zero geleverde producten is volgens wettelijke bepalingen geregeld. Een retourzending kan alleen na duidelijke afspraak en in de originele verpakking plaatsvinden. SVP een aankoopbon en een duidelijke storingsomschrijving bijvoegen. Van garantie uitgesloten zijn defecten door overbelasting, onkundig gebruik, of door deelname aan wedstrijden (SPL) ontstaan zijn. Wij behouden ons het recht om de nodige veranderingen of verbeteringen aan het product door te voeren zonder de klant hierover te informeren.

La garantie est conforme aux droits légaux. Un retour du produit défectueux doit être dans son emballage d'origine sur présentation du reçu ou de la facture indiquant la description du défaut. La présente Garantie n'est pas applicable lorsque le produit a été endommagé en raison: Mauvaise alimentation, Trop de puissance (HP, Subwoofer) Accident, Installation ou Utilisation non conforme aux normes Technique (Concours SPL etc). Nous nous réservons le droit d'entreprendre à l'avenir nécessairement des modifications ou des améliorations au produit sans informer le client.

Ground Zero GmbH

Erlenweg 25, 85658 Egming, Germany

Tel. +49 (0)8095/873 830 Fax -8310

www.ground-zero-audio.com

