



MONITOR

Monitor 7" - Wide vision TFT/LCD



ITALIANO

ENGLISH

FRANÇAIS

DEUTSCH

ESPAÑOL

***ISTRUZIONI DI MONTAGGIO
MOUNTING INSTRUCTIONS
INSTRUCTIONS DE MONTAGE
MONTAGEANLEITUNG
INSTRUCCIONES PARA EL MONTAJE***

VM 173

Collegamenti • Connections • Connexions • Anschlüsse • Conexiones

- Quando il cavo verde è collegato a +12 V attiva il monitor sull'ingresso V2.
- *When the GREEN cable is connected to +12V, the Screen gets activated on the V2-Input.*
- Lorsque le câble vert est branché à +12V, activer l'écran sur l'entrée V2
- *Wenn das GRÜNE Kabel an +12V angeschlossen ist, dann aktiviert sich der Bildschirm auf dem V2-Eingang.*
- Cuando el cable verde esta' conectado a +12 Voltios, activa el monitor en la entrada V2.

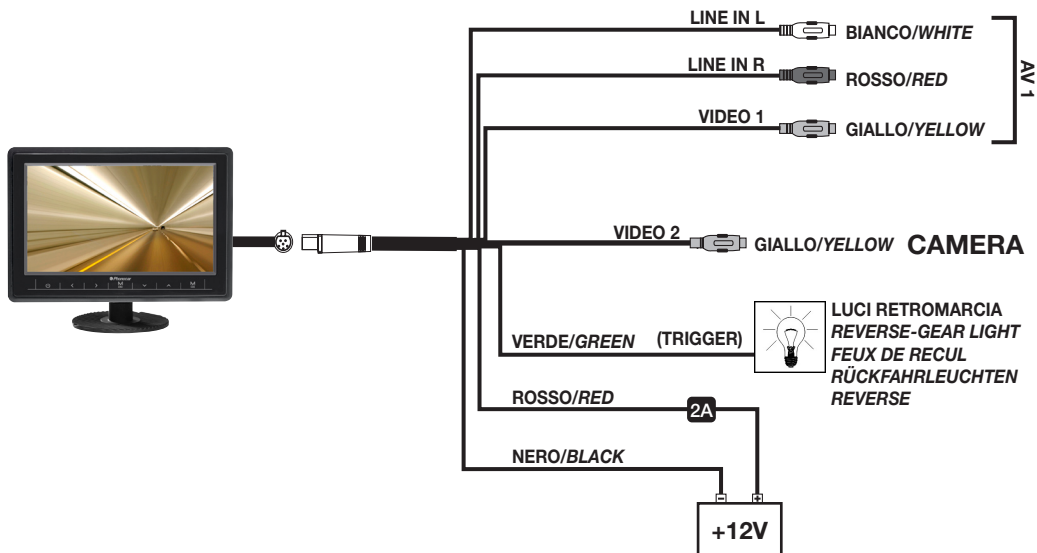

Funzioni telecomando • Remote control functions • Fonctions Télécommande Fernbedienungs-Tasten • Funciones Mando A Distancia

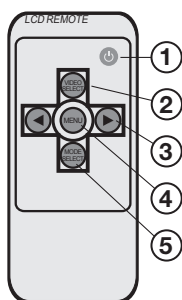

IT

1. Accende/Spegne.
2. Selezione sorgente AV1/V2.
3. Selezione ◀▶ funzioni menù.
4. Menù.
5. Formato schermo (16:9 - 4:3).

GB

1. Power: On/Off.
2. Select: AV1 or V2 sources.
3. ◀▶ Select Menu-functions.
4. Menu.
5. Picture-format 16:9-4:3.

FR

1. Appuyer ce bouton pour On et Off.
2. Sélection source: AV1 / V2.
3. ◀▶ Accéder à la fonction menu.
4. Menu.
5. Format de l'image 16:9 - 4:3.

D

1. Taste ON/OFF drücken.
2. Quellen-Wahl: AV1 / V2.
3. ◀▶ betreten der Menü-Funktion
4. Menü.
5. Bild-Format 16:9 - 4:3.

E

1. Para encender / apagar el monitor On / Off.
2. Para pasar de AV1 a V2 video select.
3. ◀▶ Acceder a la función menú
4. Menú
5. Formato de la imagen 16:9 - 4:3.

**Funzioni monitor • Monitor functions • Touches écran
Bildschirm-Tasten • Panel de control**

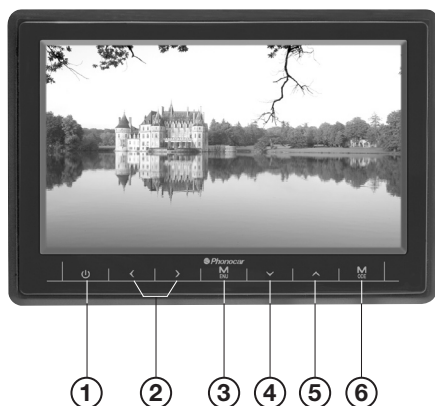

IT

1. Accende/Spagne.
2. Selezione funzioni menù.
3. Menù Luminosità/Contrasto/Colore/Rotazione/IRsend/Reset.
4. Formato schermo (16:9 - 4:3).
5. Rotazione schermo.
6. Seleziona sorgente AV1/AV2.

GB

1. On/Off.
2. Selecting the Menu-Functions.
3. Menù Brightness/Contrast/Color/Rotation/IR send/Reset.
4. Screen-Format.
5. Screen-Rotation.
6. Select Source AV1/AV2.

FR

1. Allume / Eteint.
2. Sélectionne les fonctions du menu.
3. Menu.
4. Format de l'écran (16:9 - 4:3).
5. Rotation de l'écran.
6. Sélectionne la source AV1 / V2.

D

1. Ein/Aus
2. Wahl der Menü-Funktionen
3. Menü Brightness/Contrast/Color/Rotation/IR send/Reset.
4. Bildschirm-Größe (16:9 - 4:3)
5. Bildschirm-Drehung
6. Wahl der Quelle AV1 / V2

E

1. Enciende/Apaga.
2. Selección Funciones menú.
3. Menú.
4. Formato pantalla (16:9 - 4:3).
5. Rotación pantalla.
6. Selecciona fuente de entrada AV1 / V2.

Specifiche • Specifications • Technische Daten • Characteristics

Trasmettitore IR / <i>IR transmitter</i>	A channel frequency 2.3 MHz, B channel frequency 2.8 MHz
Schermo / <i>Screen</i> :	TFT LCD
Dimensione schermo / <i>Screen size</i> :	7.0"
Formato schermo / <i>Screen format</i> :	16:9
Impostazione formato schermo / <i>Mode</i> :.....	16:9 / 4:3
Regolazioni immagini / <i>Picture-settings</i> :.....	Contrast/Color/Brightness
Rotazione immagine / <i>Picture rotation</i>	90°-180°-270°-360°
Consumo / <i>Power consumption</i> :	8.5W
Alimentazione / <i>Power supply</i> :.....	DC 12V
Luminosità / <i>Brightness</i> :.....	250 nits
Sistema / <i>System</i> :	PAL/NTSC
Ingresso / <i>Input Audio/Video</i> :	AV1
Ingresso / <i>Input Video</i>	V2
Temperatura di esercizio / <i>Operation Temperature</i> :	-10°C ~ + 60°C
Risoluzione / <i>Resolution</i> :	480(W) R/G/B×234(H)



S.p.A. - Via F.lli Cervi, 167/C • 42124 Reggio Emilia (Italy)

Tel. ++39 0522 941621 • Fax ++39 0522 942452 • www.phonocar.com • e-mail:info@phonocar.it