

# Zenith



## DATA SHEET

# AGM BATTERY HIGH CRANKING RATE ZPC120070

### Performance features

PHCA	2150A at 27°C (80°F)	5 seconds
CCA	1050A at -18°C (0°F)	
HCA	1505A at 27°C (80°F)	
CA / MCA	1300A at 0°C (32°F)	
Self-Discharge 25°C (77°F)	Capacity after 3 month storage	91%
	Capacity after 6 month storage	82%
	Capacity after 12 month storage	64%
Standard Terminal	M8	
Reserve Capacity	242Min	
Charging Cycle (constant voltage)	Charge 14.5V~14.9V/ 25°C (77°F)	
	Float 13.6V~13.8V/ 25°C (77°F)	
Short circuit current	5.000A	
Operation temperature range	-15°C (-5°F) to 50°C (122°F)	

### Specifications

Nominal Voltage		12V
Rated Capacity (20 hour rate)		105Ah
Dimension	Total Height (with terminals)	220mm (8.66 inches)
	Height	214mm (8.43 inches)
	Length	328mm (12.91 inches)
	Width	172mm (6.77 inches)
Weight		Approx. 34kg (74.96lbs)

### High rate discharge at 25°C (77°F)

5 sec	10 sec	20 sec	30 sec
2150A	1975A	1700A	1520A

### Extended discharge at 25°C (77°F) to 10,02V

5 min.	15 min.	1h	3h	5h	10h	20h
425A	210A	72A	30A	20A	11.4A	6A

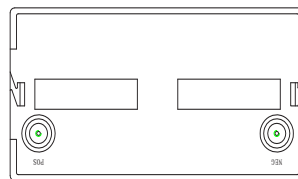
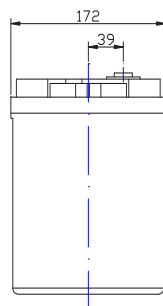
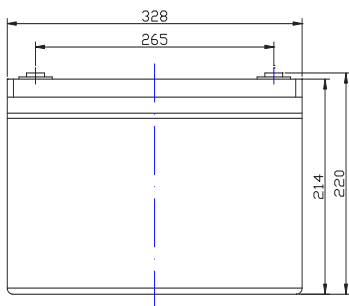

### Terminal

unit:mm

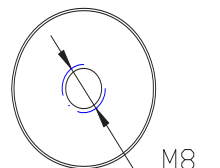
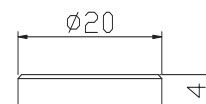

This information is generally descriptive only and is not intended to make or imply any representation, guarantee or warranty with respect to any cells and batteries. Cell and battery designs/specification are subject to modification without notice. Contact U.B.S. UNION BATTERY SERVICE for the latest information.

[www.zenithdcbattery.com](http://www.zenithdcbattery.com)

DIVISION OF



[www.unionbatteryservice.it](http://www.unionbatteryservice.it)