

# Zenith



## DATA SHEET

# AGM BATTERY HIGH CRANKING RATE ZPC120015

### Performance features

PHCA	370A at 27°C (80°F)	5 seconds
PCCA	210A at -18°C (0°F)	5 seconds
CCA	156A at -18°C (0°F)	
CA / MCA	190A at 0°C (32°F)	
Self-Discharge 25°C (77°F)	Capacity after 3 month storage	91%
	Capacity after 6 month storage	82%
	Capacity after 12 month storage	64%
Standard Terminal	M6M	
Reserve Capacity	25Min	
Charging Cycle (constant voltage)	Charge 14.5V~14.9V/ 25°C (77°F)	
	Float 13.6V~13.8V/ 25°C (77°F)	
Short circuit current	880A	
Operation temperature range	-15°C (-5°F) to 50°C (122°F)	

### Specifications

Nominal Voltage		12V
Rated Capacity (20 hour rate)		15Ah
Dimension	Total Height (with terminals)	138mm (5.43 inches)
	Height	134mm (5.25 inches)
	Length	200mm (7.87 inches)
	Width	78mm (3.07 inches)
Weight		Approx. 5.55 kg (12.24lbs)

### High rate discharge at 25°C (77°F)

5 sec	10 sec	20 sec	30 sec
370A	335A	287A	255A

### Extended discharge at 25°C (77°F) to 10,02V

5 min.	15 min.	1h	3h	5h	10h	20h
70.7A	32.4A	10.9A	4.29A	2.73A	1.45A	0.76A

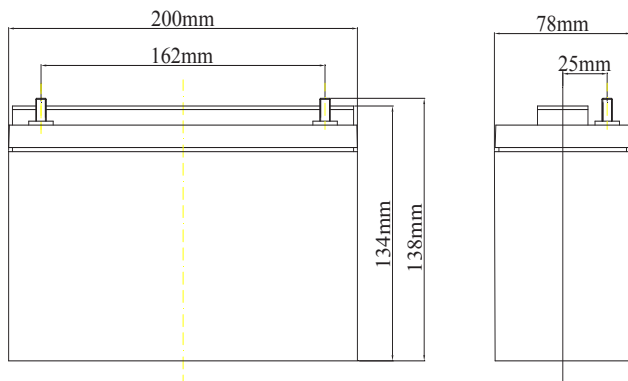

Terminal: M6M  
unit:mm

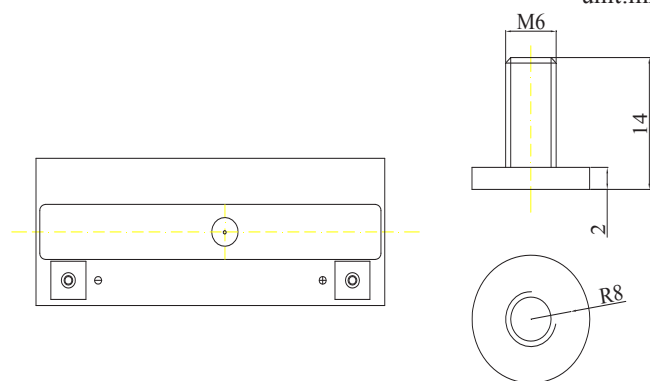

This information is generally descriptive only and is not intended to make or imply any representation, guarantee or warranty with respect to any cells and batteries. Cell and battery designs/specification are subject to modification without notice. Contact U.B.S. UNION BATTERY SERVICE for the latest information.

[www.zenithdcbattery.com](http://www.zenithdcbattery.com)

DIVISION OF



[www.unionbattery.com](http://www.unionbattery.com)