

12.301301-05

Pioneer sound.vision.soul

1198-2003 LEXUS GS 300 **Pioneer**
1198-2003 LEXUS GS 400 *ound.vision.soul*

KIT ASSEMBLY INSTRUCTIONS

Double DIN & Double ISO Mount Applications

- 1) Remove the Shaded tab from the bottom of each left and right mounting bracket (see Fig. B below).
- 2) Cut and remove center rib from main bracket for double DIN and double ISO applications
- 3) Attach the left and right side brackets to the main bracket.
- 4) Attach climate controls to the top of the kit using factory screws.
- 5) For double DIN radio applications **ONLY** cut and remove center rib from and file edges smooth.
- 6) Follow steps 5-7 from single ISO instructions on page 2.
- 7) Attach a rear support bracket to the rear of the radio components and adjust as needed to allow rear support bracket to rest in the sub-dash.

NOTE: ISO trim rings must be used in place of after-market radio's trim rings. For ISO mount applications, mount after-market radio components to side brackets using screws provided with radio when possible or hardware included with kit.

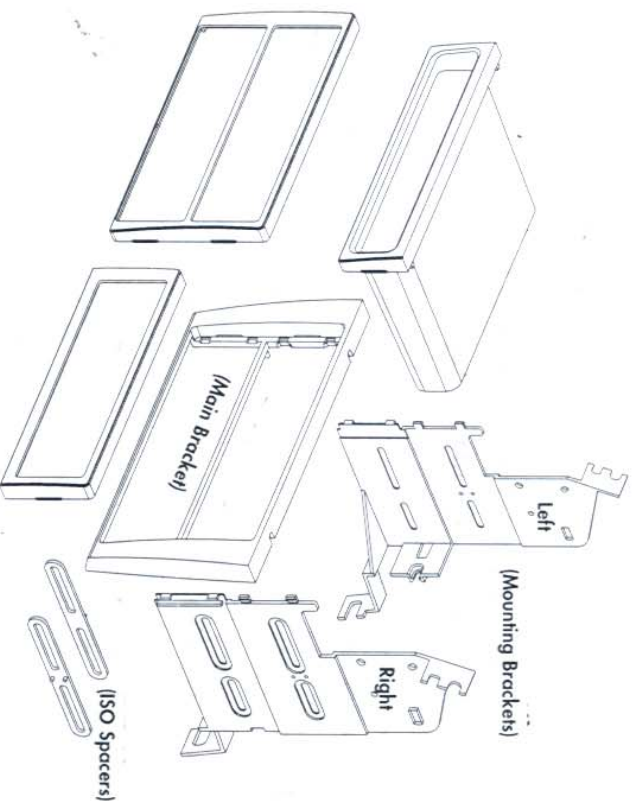
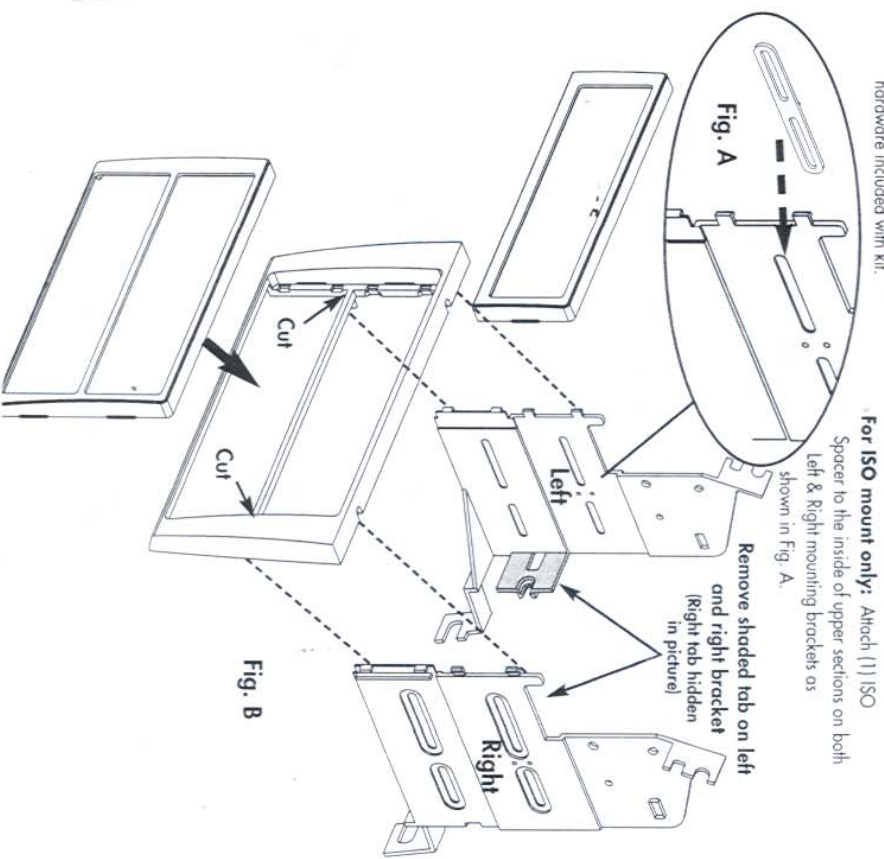

RADIO MOUNTING KIT INSTALLATION INSTRUCTIONS

KIT DISASSEMBLY INSTRUCTIONS

- 1) Carefully unsnap and pull forward the vent/clock assembly from above the factory radio.
- 2) Unplug the wire harnesses from the rear of the vent/clock assembly and remove assembly.
- 3) Remove the (2) 10mm bolts securing the upper radio/climate control brackets to the sub-dash.
- 4) Carefully remove the ashtray assembly from below the climate controls.
- 5) Remove the (2) 10mm bolts securing the lower radio/climate control brackets to the sub-dash.
- 6) Carefully pull radio/climate control assembly forward, disconnect all wire harnesses and antenna lead wire from radio and climate controls and remove entire assembly.
- 7) Remove the factory climate control unit from the factory brackets.

KIT ASSEMBLY INSTRUCTIONS

Single DIN Mount Applications

- 1) Attach the left and right side brackets to the main bracket.
- 2) Insert pocket into lower section of the main bracket.
- 3) Attach left and right side brackets to the rear of the pocket using screws supplied.
- 4) Insert DIN sleeve from your new radio into the upper section of the installation kit.
- 5) Depress the tabs from inside the sleeves opening upward, outward, and downward to secure sleeve to the installation kit.
- 6) Install radio into sleeve and lock into place.
- 7) Attach a rear support bracket to the rear of the new radio and adjust as necessary to attach to the rear support stud located on the back of the pocket using the small phillips screw supplied with kit.

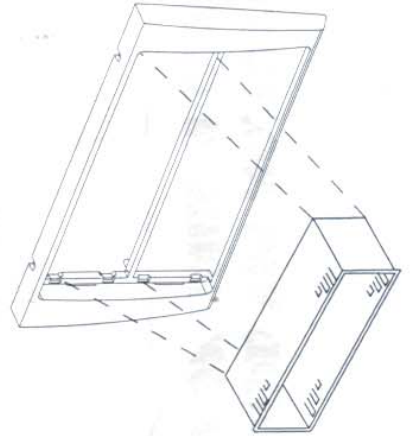

KIT ASSEMBLY INSTRUCTIONS

Single ISO Mount Applications

- 1) Attach the left and right side brackets to the main bracket.
- 2) Insert pocket into lower section of the main bracket.
- 3) Attach left and right side brackets to the rear of the pocket using screws supplied.
- 4) Attach climate controls to the top of the kit using factory screws.
- 5) Attach (1) ISO Spacer to the inside of upper section on both Left & Right mounting brackets as shown in Fig. A.
- 6) Insert ISO mountable radio between ISO mount brackets and loosely attach to sides of radio using screws provided with radio when possible or hardware included with kit.
- 7) Slide radio components forward or backward for desired look and tighten screws.
- 8) Attach a rear support bracket to the rear of the new radio and adjust as necessary to attach to the rear support stud located on the back of the pocket using the small phillips screw supplied with kit.

For ISO mount only: Attach (1) ISO Spacer to the inside of upper section on both Left & Right mounting brackets as shown in Fig. A.

