

2-DIN 12.301300-20

APPLICATIONS

TOYOTA CAMRY / CAMRY HYBRID 2007

KIT FEATURES

- DIN Radio Provision with Pocket
- ISO Radio Provision with Pocket
- Double DIN Radio Provision
- Stacked ISO Units Provision



KIT COMPONENTS

A) Radio Housing | B) Radio Housing Brackets | C) ISO Snap-In Brackets | D) Double DIN Brackets

E) Trim Plate | F) Double DIN Trim Plate | G) Pocket | H) (4) # 8 x 3/8 Phillips Screws | I) (4) #4 x 1/4 Phillips Screws

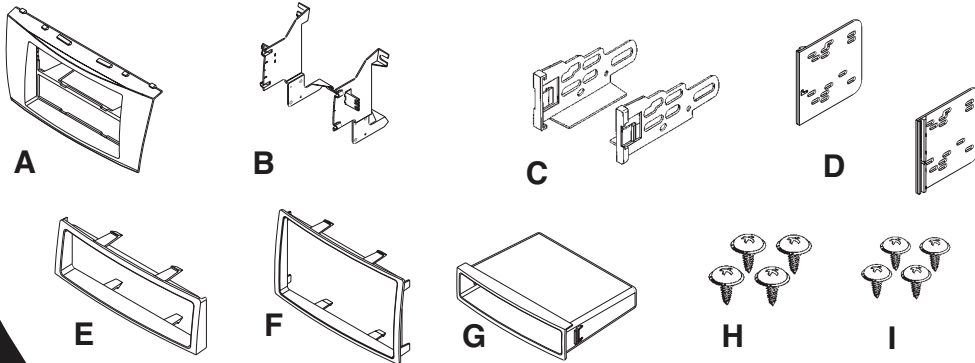

TOOLS REQUIRED:

Phillips Screwdriver • Socket Wrench • Small Flat Blade Screwdriver or Panel Removal Tool

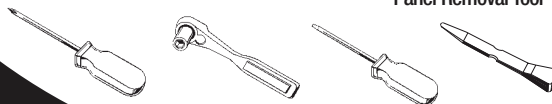

TABLE OF CONTENTS

Dash Disassembly

- Toyota Camry / Camry Hybrid 2007..... 1, 2**

Kit Assembly

- DIN Radio Provision with Pocket 3**
- ISO Radio Provision with Pocket 4**
- Double DIN Radio Provision 5**
- Stacked ISO Units Provision 6**

- Final Assembly 7**

TOYOTA CAMRY / CAMRY HYBRID 2007

- 1** Disconnect the negative battery terminal to prevent an accidental short circuit.
- 2** Turn the shift knob counterclockwise to remove.
- 3** Unclip and remove (1) trim panel from each side of the pocket below the radio/climate control assembly. (2 panels total)
(Figure A)

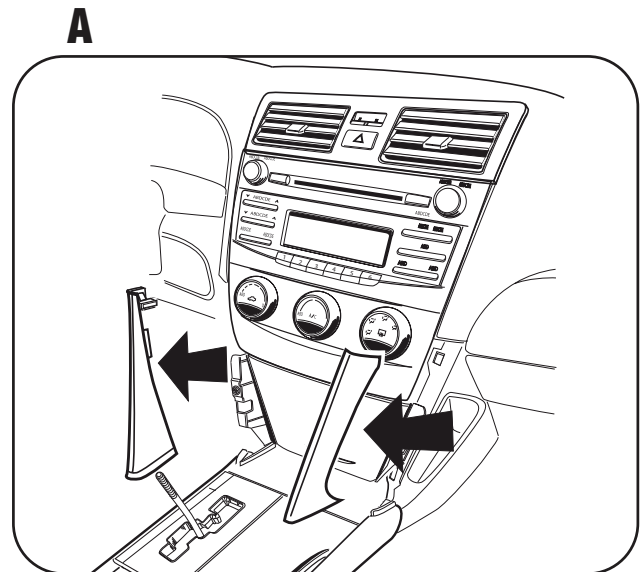

- 4** Unclip and remove the shift knob trim panel. **(Figure B)**
- 5** Unclip and remove the top of the center console including the cup holders. **(Figure B)**

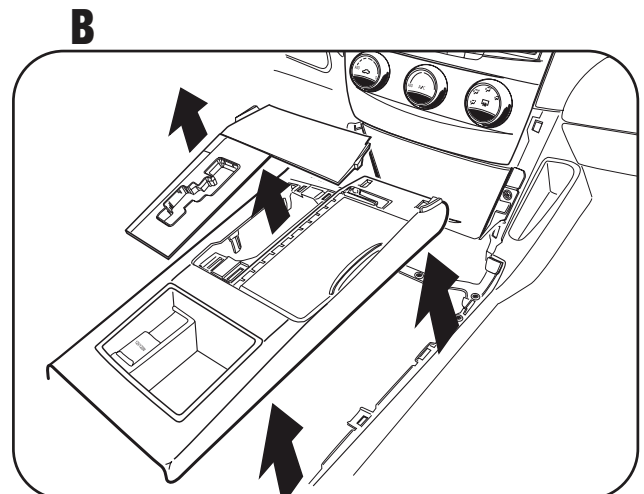

- 6** Remove (1) Phillips screw from each side of pocket below the radio/climate control assembly (2 screws total). **(Figure C)**
- 7** Unclip and remove the pocket. **(Figure C)**

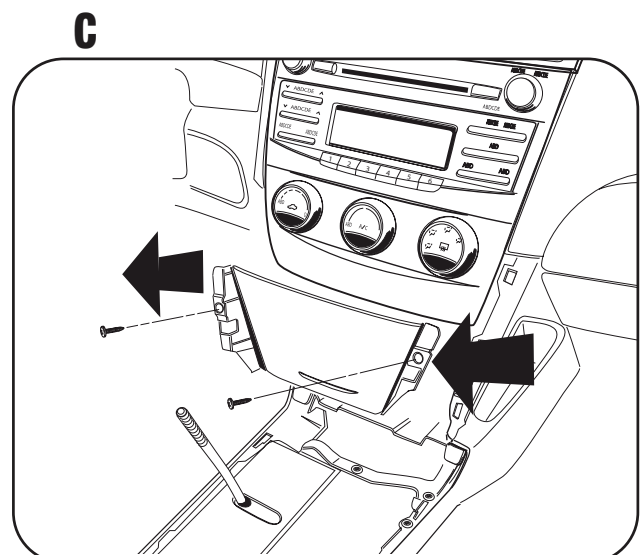

Continued on Page 2.

TOYOTA CAMRY / CAMRY HYBRID 2007

- 8** Unclip and remove the A/C vents above the radio. (Take care not to scratch the dash panel. **(Figure A)**)

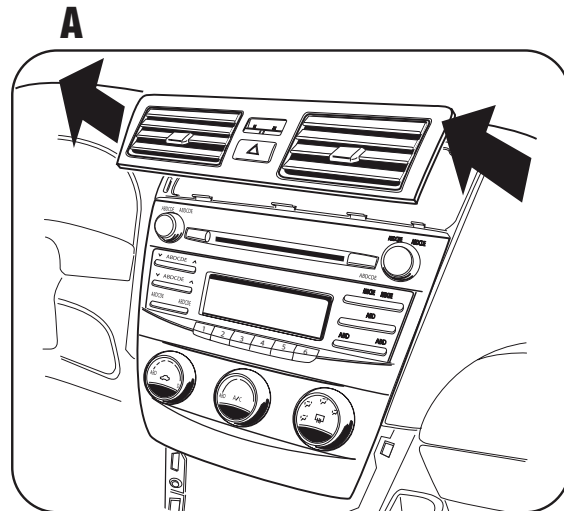

- 9** Remove (2) 10mm bolts above the radio (behind the A/C vents) and (2) 10mm bolts below the climate controls (behind pocket) then unplug and remove the radio/climate control assembly. **(Figure B)**

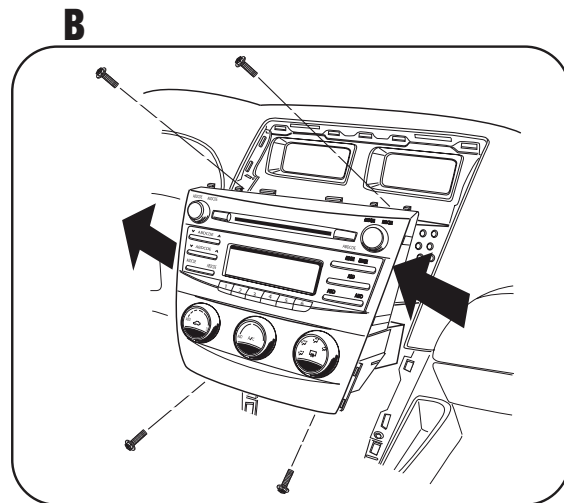

- 10** Remove the (10) Phillips screws securing the brackets to the radio/climate control assembly and separate the radio from the climate controls. (Retain climate controls and screws for use during kit assembly). **(Figure C)**

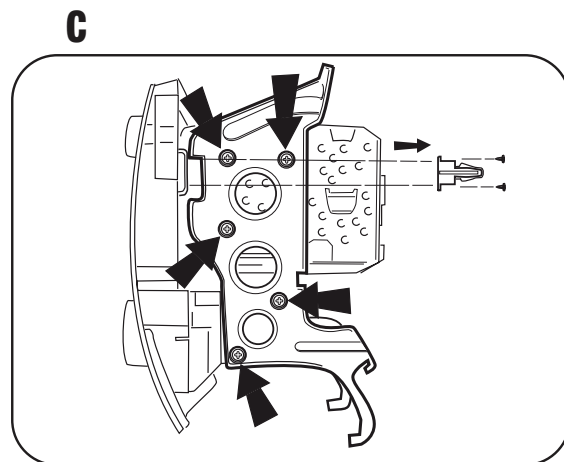

- 11** Unscrew and remove the (2) Clips from the back of the factory radio. (Retain clips for use during kit assembly. **(Figure C)**)

Continue to kit assembly.

DIN RADIO PROVISION WITH POCKET

NOTE: Refer also to the instructions included with the aftermarket radio.

- 1 Slide the DIN cage into the Radio Housing and secure by bending the metal locking tabs down. **(Figure A)**
- 2 Slide the after-market radio into the cage until it snaps into place. **(Figure B)**
- 3 Snap the pocket into the radio housing. **(Figure B)**
- 4 Align the small legs on the bottom of the radio housing with the slots in the top of the climate control. Then slide the climate control sideways to engage together. **(Figure C)**
- 5 Attach the radio housing brackets to the radio housing using the included Phillips screws. **(Figure D)**
- 6 Secure the radio housing brackets to the climate control using the factory hardware. **(Figure D)**
- 7 Attach the (2) clips removed in step 11 in dash disassembly to the radio housing brackets using the supplied small Phillips screws. **(Figure D)**

Continue to Final Assembly.

A

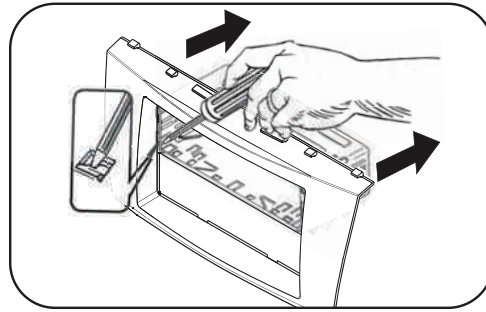

B

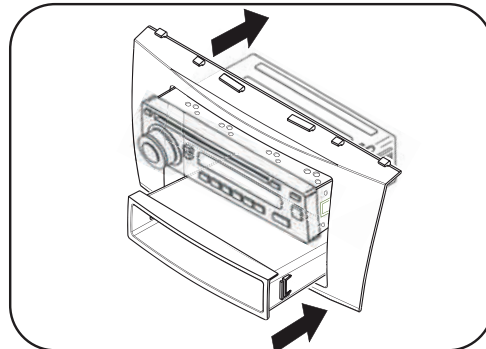

C

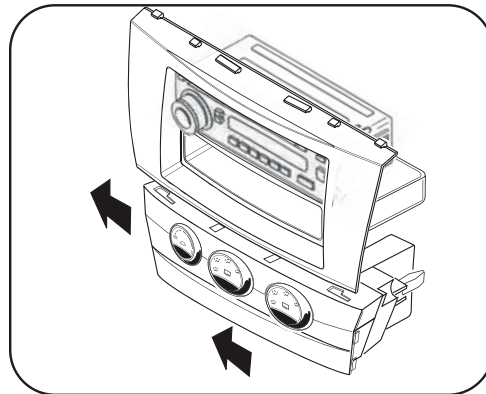

D

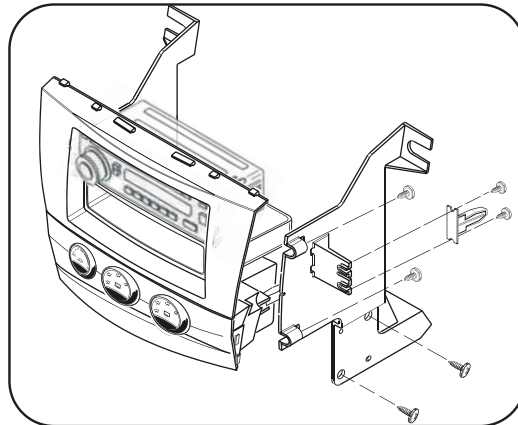

3

ISO RADIO PROVISION WITH POCKET

NOTE: Refer also to the instructions included with the aftermarket radio.

- 1 Mount the ISO Brackets to the radio with the screws supplied with the radio. **(Figure A)**
- 2 Slide the radio into the radio opening until the side clips engage. **(Figure B)**
- 3 Snap the Trim plate into the Radio Housing. **(Figure B)**
- 4 Snap the pocket into the radio housing. **(Figure B)**
- 5 Align the small legs on the bottom of the radio housing with the slots in the top of the climate control. Then slide the climate control sideways to engage together. **(Figure C)**
- 6 Attach the radio housing brackets to the radio housing using the included Phillips screws. **(Figure D)**
- 7 Secure the radio housing brackets to the climate control using the factory hardware. **(Figure D)**
- 8 Attach the (2) clips removed in step 11 in dash disassembly to the radio housing brackets using the supplied small Phillips screws. **(Figure D)**

Continue to Final Assembly.

A

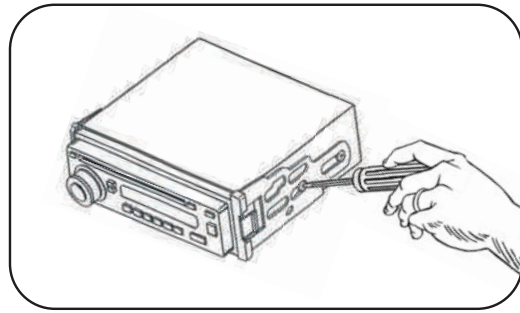

B

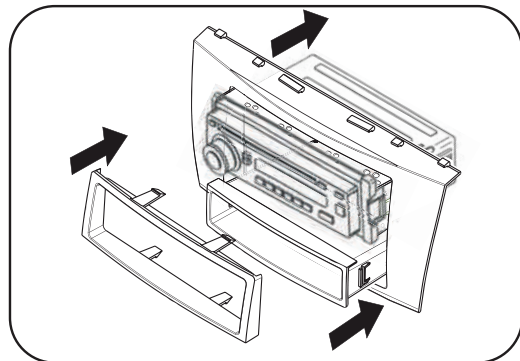

C

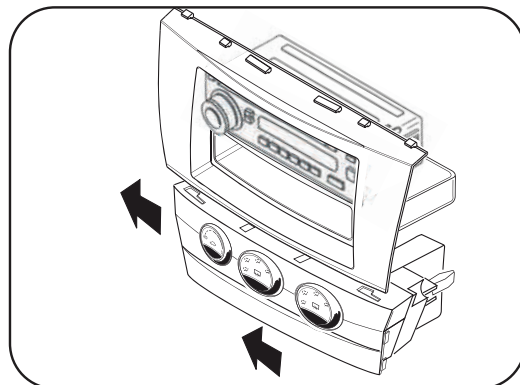

D

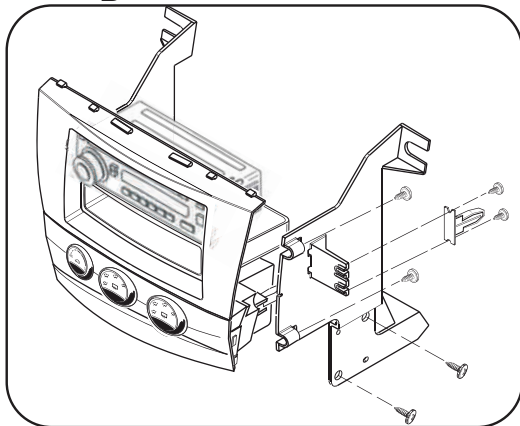

DOUBLE DIN RADIO PROVISION

NOTE: Refer also to the instructions included with the aftermarket radio.

- 1** Cut and remove center divider from radio housing. **(Figure A)**
- 2** Snap the Double DIN brackets to the inside edge of the radio housing. **(Figure B)**
- 3** Slide the Double DIN radio into the Double DIN bracket/radio housing assembly and secure the radio to the assembly using the screws supplied with the radio. **(Figure C)**
- 4** Snap the Double DIN trim-plate into the housing/radio assembly. **(Figure C)**
- 5** Align the small legs on the bottom of the radio housing with the slots in the top of the climate control then slide the climate control sideways to engage together. **(Figure D)**
- 6** Attach the corresponding radio housing bracket to the radio housing using the included Phillips screws. **(Figure E)**
- 7** Secure the radio housing brackets to the climate control using the factory hardware. **(Figure E)**
- 8** Attach the (2) clips removed in step 11 in dash disassembly to the radio housing brackets using the supplied small Phillips screws. **(Figure E)**

Continue to Final Assembly.

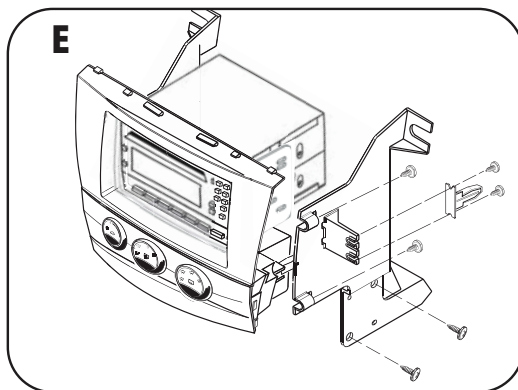
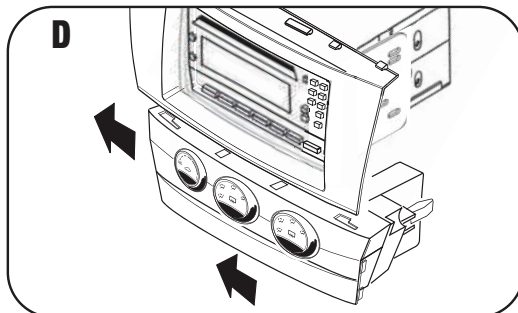
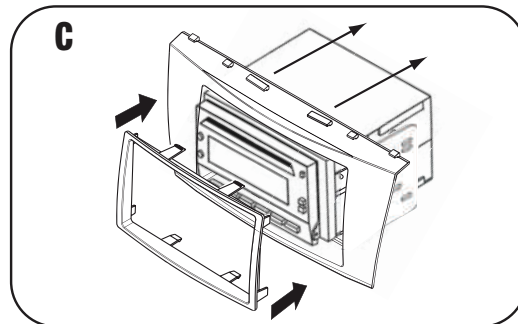
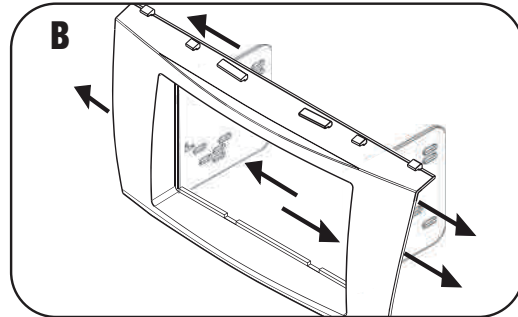
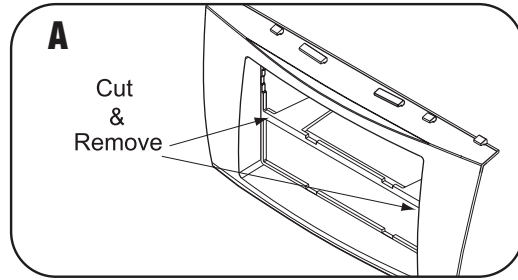

STACKED ISO UNITS PROVISION

NOTE: Refer also to the instructions included with the aftermarket radio.

- 1** Cut and remove center divider from radio housing. (**Figure A**)
- 2** Snap the Double DIN brackets to the inside edge of the radio housing. (**Figure B**)
- 3** Slide the Stacked ISO units into the Double DIN bracket/radio housing assembly and secure the radio to the assembly using the screws supplied with the units. (**Figure C**)
- 4** Snap the Double DIN trim-plate into the housing/radio assembly. (**Figure C**)
- 5** Align the small legs on the bottom of the radio housing with the slots in the top of the climate control then slide the climate control sideways to engage together. (**Figure D**)
- 6** Attach the corresponding radio housing bracket to the radio housing using the included Phillips screws. (**Figure E**)
- 7** Secure the radio housing brackets to the climate control using the factory hardware. (**Figure E**)
- 8** Attach the (2) clips removed in step 11 in dash disassembly to the radio housing brackets using the supplied small Phillips screws. (**Figure E**)

Continue to Final Assembly.

