

## **APPLICATIONS**

### **MAZDA**

**2001-2002 626 / 1998-2005 Miata**

**1995-2002 Millennia**

**2001-2004 Protege / 2001-2004 Protege 5**

**2001-2005 Tribute / 1996-1999 MPV**

# 12.301170-04



### **KIT FEATURES**

- DIN Head Unit Provisions with Pocket
- Double DIN Head Unit Provisions
- Stacked ISO DIN Head Unit Provisions

### **KIT COMPONENTS**

A) Radio Housing (Single DIN w/ Pocket) | B) Double DIN Trim Plate | C) Double DIN Brackets | D) Rear Support

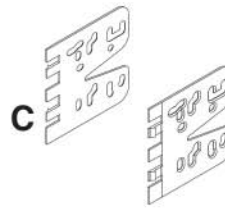
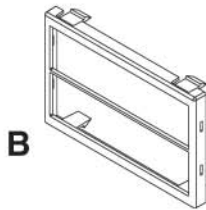
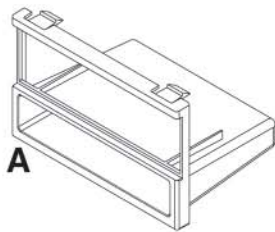

### **TOOLS REQUIRED:**

Ford Radio Removal Keys | Cutting Tool | Small Flathead Screwdriver | Phillips Screwdriver  
(2 Sets) 86-5618

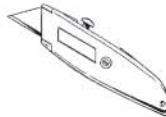

# TABLE OF CONTENTS

<i>Dash Disassembly</i> .....	<b>1</b>
<i><u>Kit Assembly</u></i>	
<i>DIN Head Unit Provisions</i> .....	<b>2</b>
<i>Double DIN Head Unit Provisions</i> .....	<b>3</b>
<i>Stacked ISO DIN Head Unit Provisions</i> .....	<b>4</b>
<i>Final Assembly</i> .....	<b>5</b>

## **ALL VEHICLES**

- 1** Disconnect the negative battery terminal to prevent an accidental short circuit.
- 2** Using small flathead screwdriver, carefully remove the trim covers from both sides of the radio. (Figure A)
- 3** Insert 2 sets of Ford radio removal keys into the sides of the radio until they snap in. (Figure B)
- 4** Gripping both sets of removal keys, pull keys outward away from the radio then slide radio out. (Figure C)

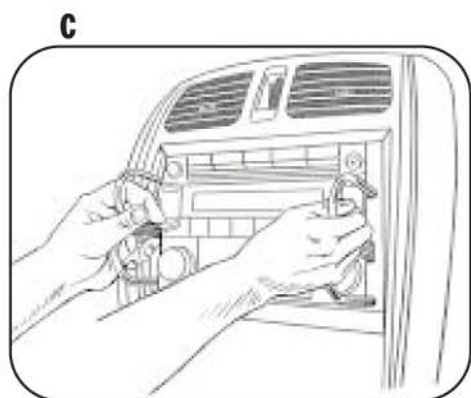
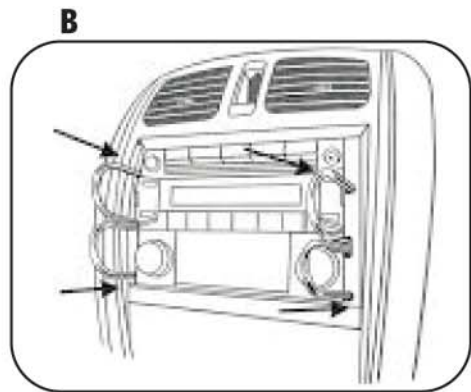
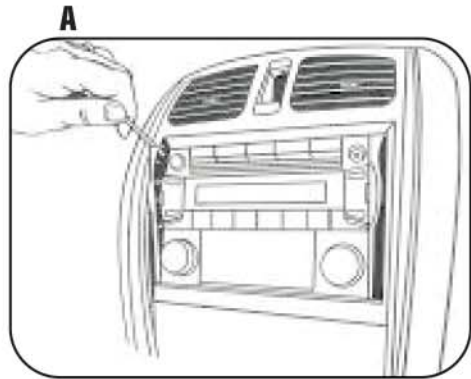

**DASH DISASSEMBLY**

## **DIN HEAD UNIT PROVISIONS**

- 1** Slide the DIN cage into the Radio Housing and secure by bending the metal locking tabs down. (Figure A)
- 2** Slide the aftermarket head unit into the cage and secure. (Figure B)
- 3** Using the hardware that came with the aftermarket radio secure the rear support to the back of the aftermarket radio. (Figure C)

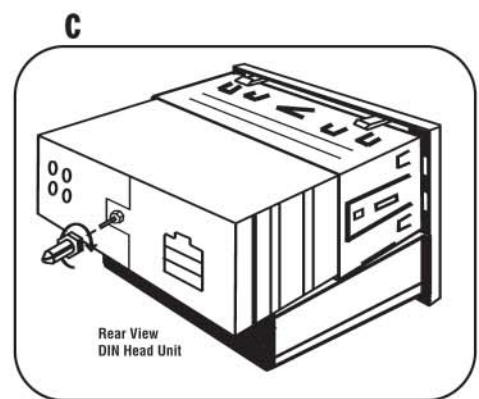
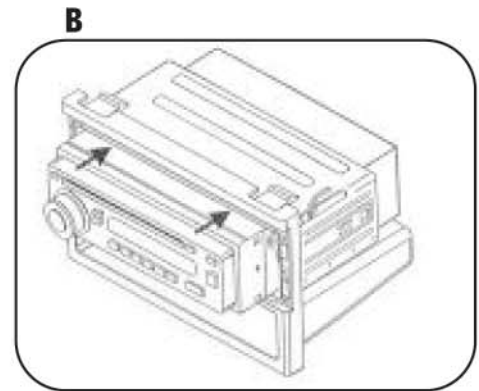
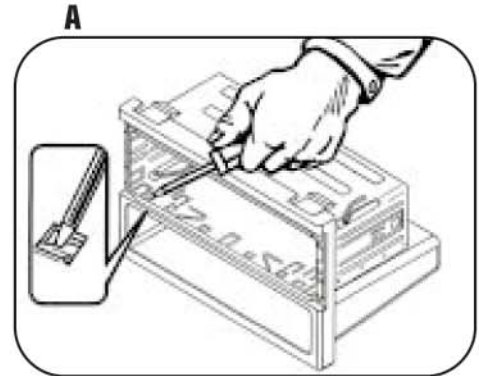

## **DOUBLE DIN HEAD UNIT PROVISIONS**

- 1** Using a cutting tool remove the center bar from the Double DIN trim plate. (Figure A)
- 2** Slide the appropriate side bracket into the Double DIN trim plate aligning the holes in the trim plate to the clips on the bracket. (Figure B)
- 3** Slide the DDIN radio unit into the trim plate bracket assembly and secure the unit to the kit using the screws supplied with the head unit. (Figure C)
- 4** Using the hardware that came with the aftermarket radio secure the rear support to the back of the aftermarket radio. (Figure D)

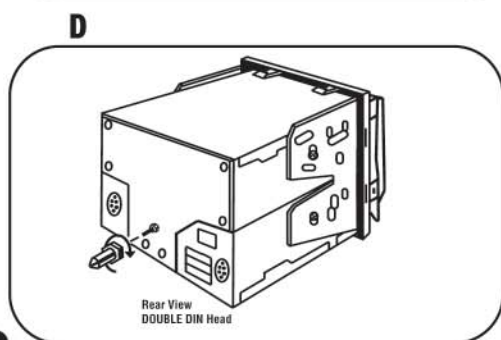
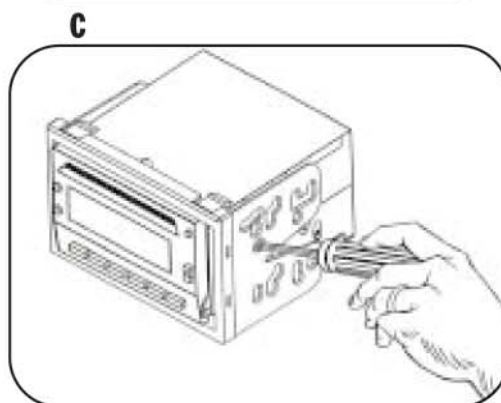
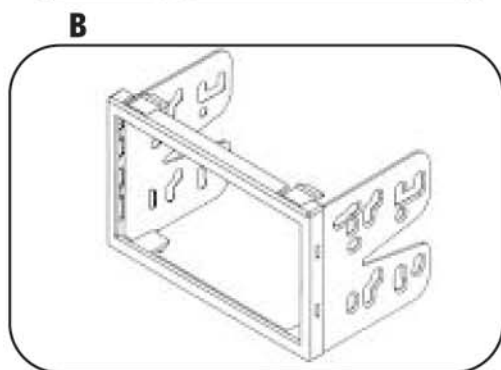
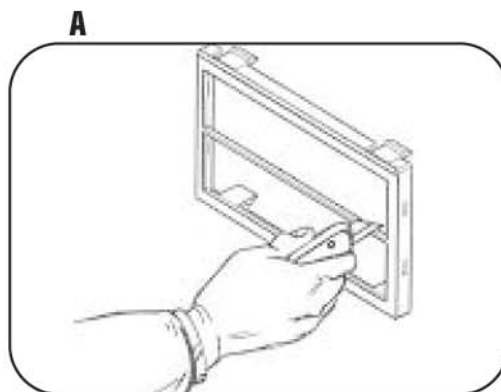

**KIT ASSEMBLY**

## **STACKED ISO DIN HEAD UNIT PROVISIONS**

- 1** Slide the appropriate side bracket into the Double DIN trim plate aligning the holes in the trim plate to the clips on the bracket.
- 2** Slide the stacked ISO DIN units into the trim plate bracket assembly and secure the units to the kit using the screws supplied with the head units. (Figure A)
- 3** Using the hardware that came with the aftermarket radio secure the rear support to the back of the aftermarket radio. (Figure B)

**A**

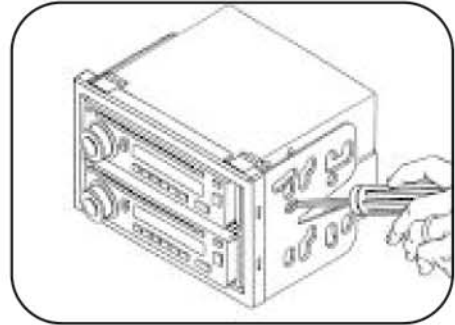

**B**

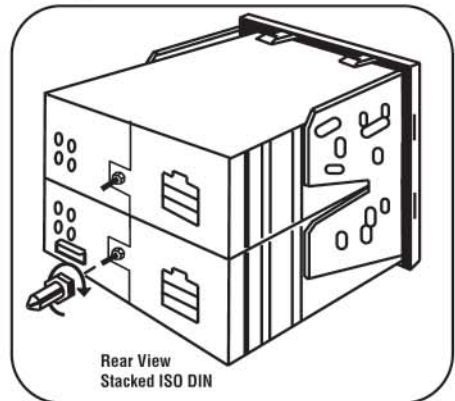

Rear View  
Stacked ISO DIN