

2-DIN 12.301142-15

APPLICATIONS
Hyundai Azera 2006



KIT FEATURES

- Double DIN Radio Provision
- Stacked ISO Units Provision

KIT COMPONENTS

A) Double Din Trim Plate • B) Double DIN Brackets

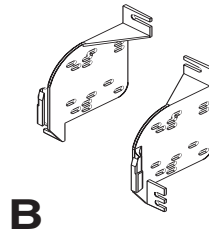
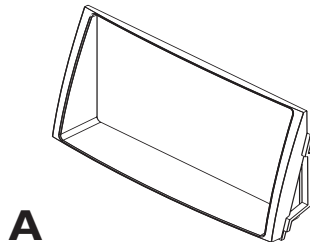

TOOLS REQUIRED:

Small Flat Blade Screwdriver/ Panel Removal Tool
• Phillips Screwdriver



TABLE OF CONTENTS

Dash Disassembly

- Hyundai Azera 2006 1,2

Kit Assembly

- Double DIN Radio Provision 3

- Stacked ISO Units Provision 4

Final Assembly 5

***Note:**

Refer also to the instructions included with the aftermarket radio.

HYUNDAI AZERA 2006

1 Disconnect the negative battery terminal to prevent an accidental short circuit.

2 Remove (1) Phillips head screw from bottom right hand corner then unclip and let the panel below the steering column hang. (Figure A)

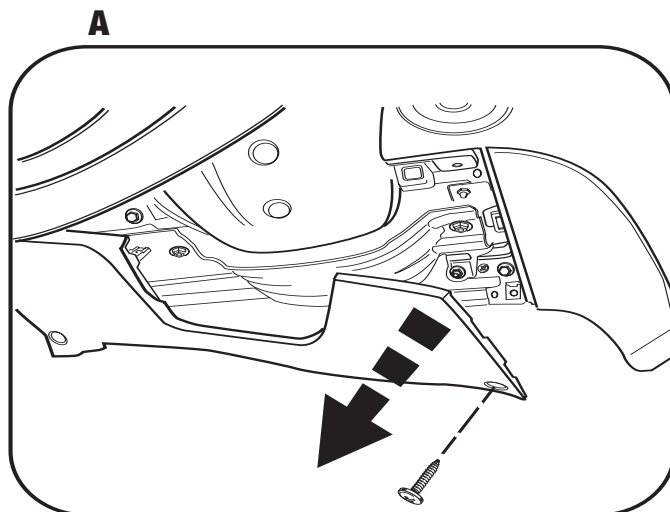

3 Remove (1) Phillips screw from the lower left side of the radio panel behind panel removed in step 2. (Figure B)

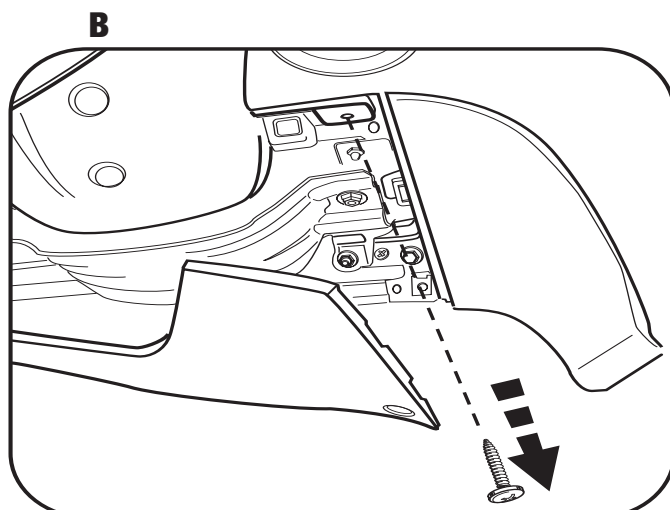

4 Unclip and remove the trim panel above the radio that extends across the dash to the passenger side. (Figure C)

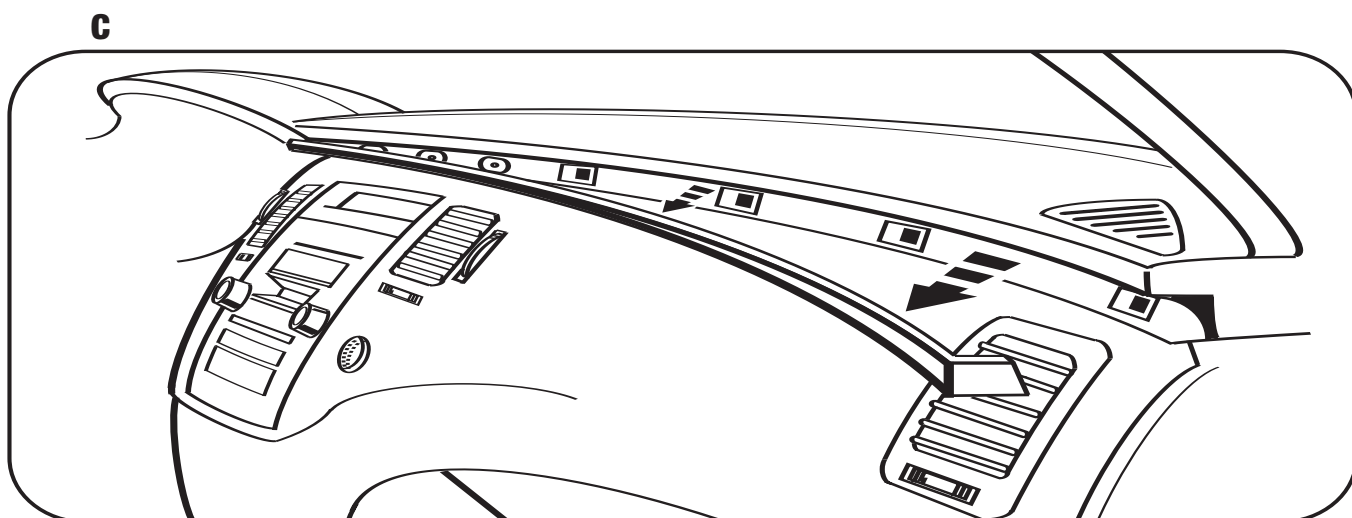

HYUNDAI AZERA 2006

- 5** Remove (3) Phillips screws from the top of the radio trim panel. (Figure D)
- 6** Remove (2) Phillips screws from under radio trim panel. (Figure E)
- 7** Unclip and remove the entire trim panel surrounding the radio. (Figure F)
- 8** Remove (4) Phillips screws securing the radio. Unplug and remove radio. (Figure G)

Continue to kit assembly.

D

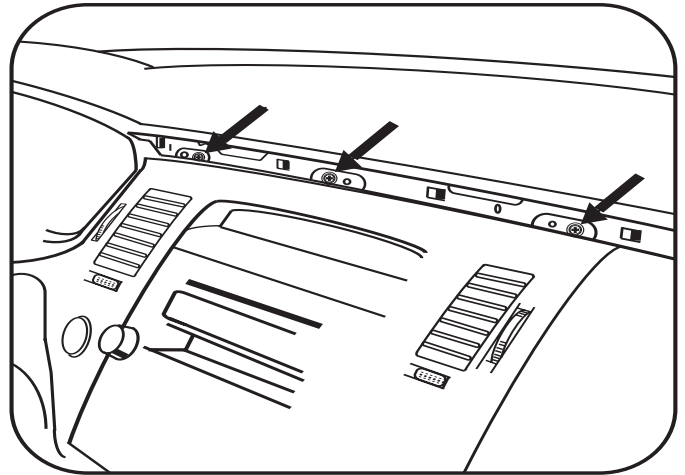

E

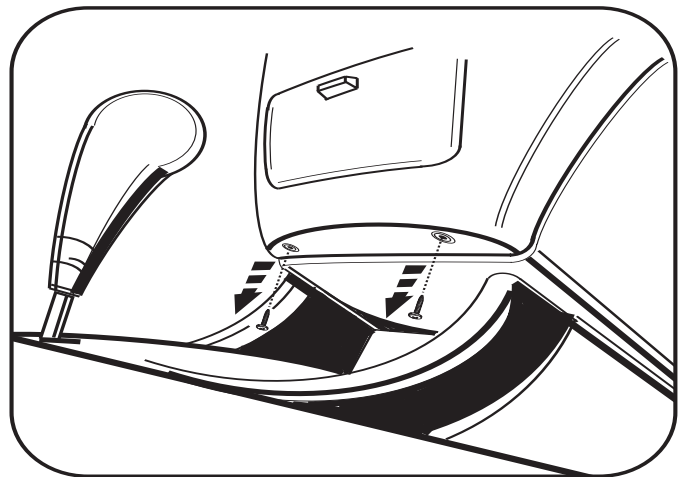

F

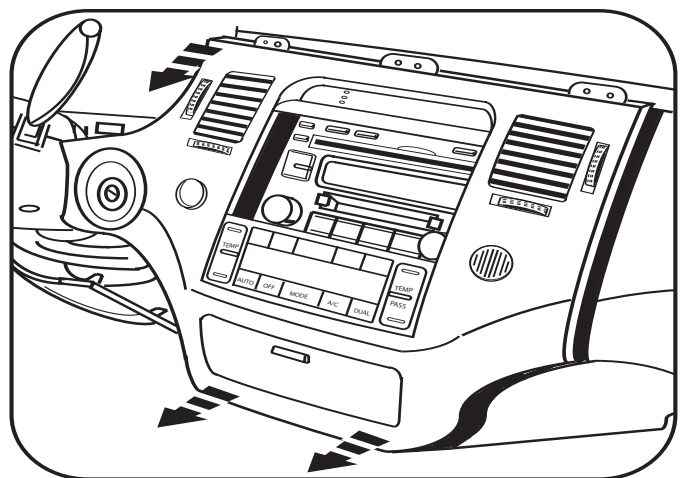

G

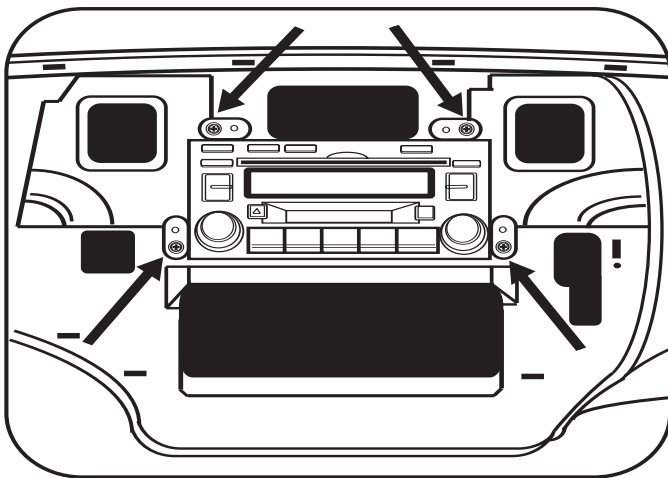

DOUBLE DIN RADIO PROVISION

**Note: Refer also to the instructions included with the aftermarket radio.*

- 1 Snap the Double DIN brackets to the outside edge of the Double DIN trim plate. (Figure A)
- 2 Slide the Double DIN radio into the bracket/trim plate assembly and secure the radio to the assembly using the screws supplied with the radio. (Figure B)

Continue to final assembly.

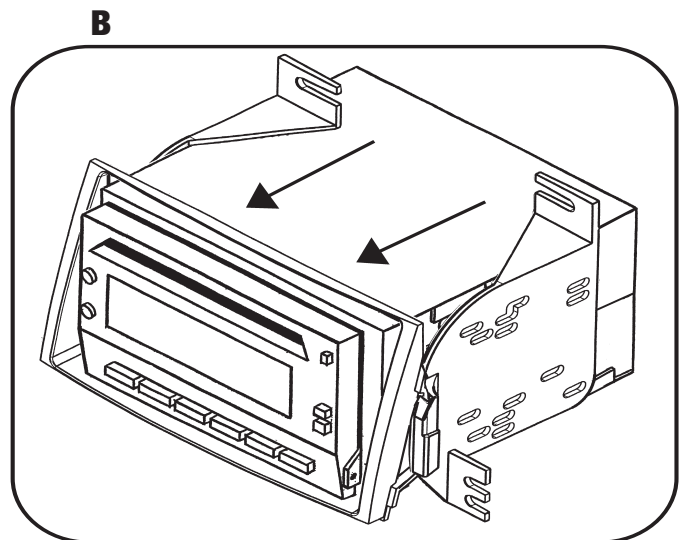
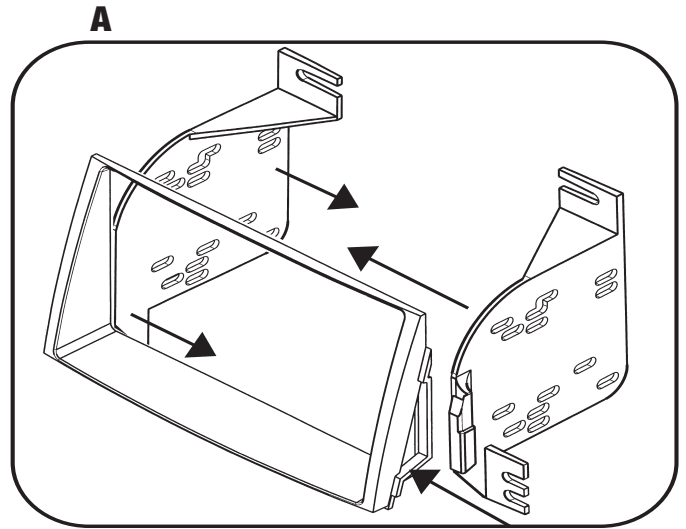

STACKED ISO UNITS PROVISION

**Note: Refer also to the instructions included with the aftermarket radio.*

- 1 Snap the Double DIN brackets to the outside edge of the Double DIN trim plate. (Figure A)
- 2 Slide the stacked ISO units into the bracket/radio housing assembly and secure the units to the kit using the screws supplied with the units. (Figure B)

Continue to final assembly.

