

APPLICATIONS
Cadillac Escalade 2007



KIT FEATURES

- ISO Mount Radio Provision With Pocket
- Double DIN Radio Provision
- Stacked ISO Units Provision

KIT COMPONENTS

- A) Radio Housing
- B) Radio Housing Trim Plate
- C) Radio Housing Brackets
- D) Pocket
- E) 4) #8 3/8" Screws

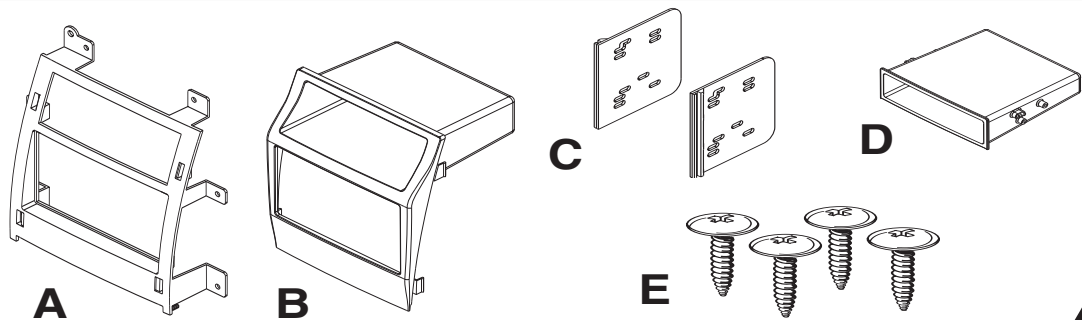

TOOLS REQUIRED:

- Small Flat Blade Screwdriver/ Panel Removal Tool
- Phillips Screwdriver
- Socket Set

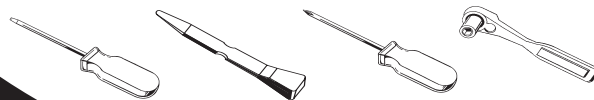

TABLE OF CONTENTS

Dash Disassembly

- Cadillac Escalade 2007 1

Kit Assembly

- ISO Mount Radio Provision with Pocket 2

- Double DIN Radio Provision 3

- Stacked ISO Units Provision 4

Final Assembly 5

***Note:**

Refer also to the instructions included with the aftermarket radio.

CADILLAC ESCALADE 2007

1 Disconnect the negative battery terminal to prevent an accidental short circuit.

2 Unclip and remove cup holder and ashtray assembly. (Figure A)

3 Unclip and remove the trim panel above the glove box including the a/c vent. (Figure B)

4 Unclip and remove the entire panel surrounding the radio including the a/c vents. (Figure C)

5 Remove (6) 9/32" screws to extract radio from dash. (Figure D)

Continue to kit assembly.

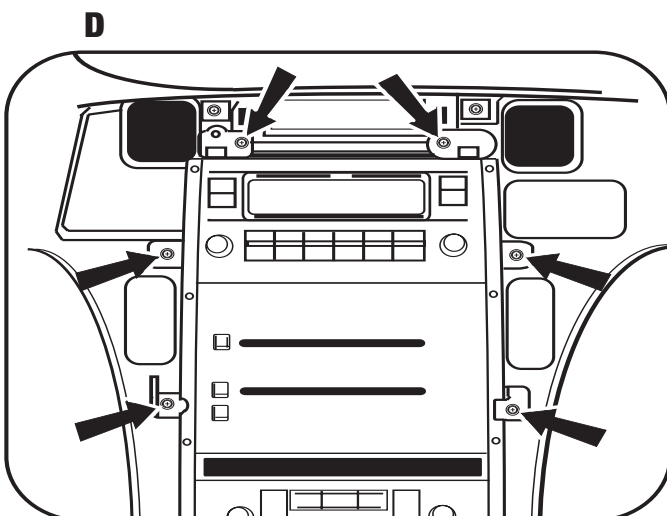
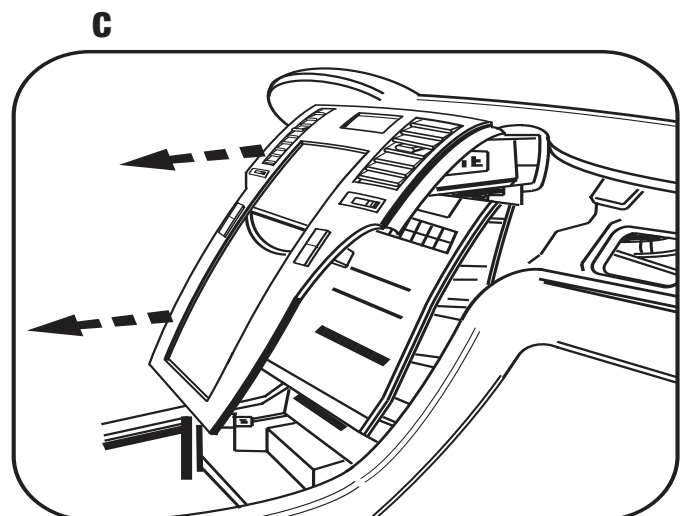
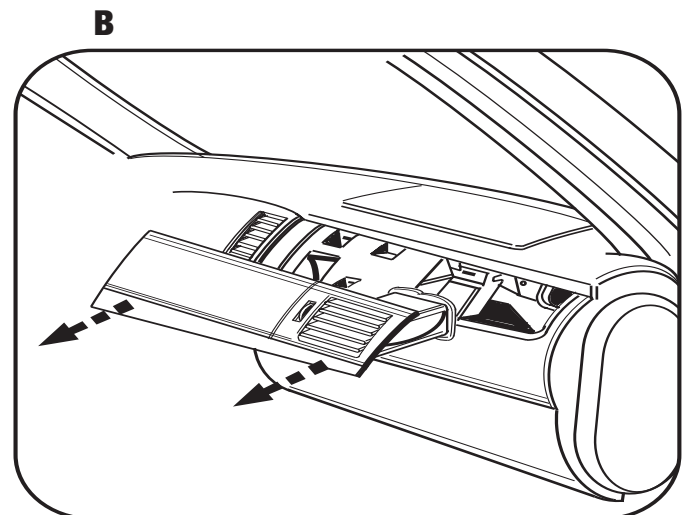
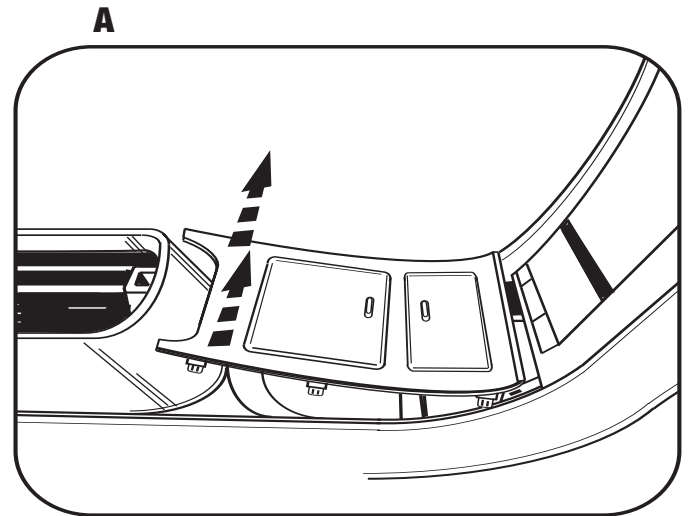

ISO MOUNT RADIO PROVISION WITH POCKET

**Note: Refer also to the instructions included with the aftermarket radio.*

- 1 Flip the radio housing brackets upside down then snap them to the inside edge of the radio housing. (Figure A)

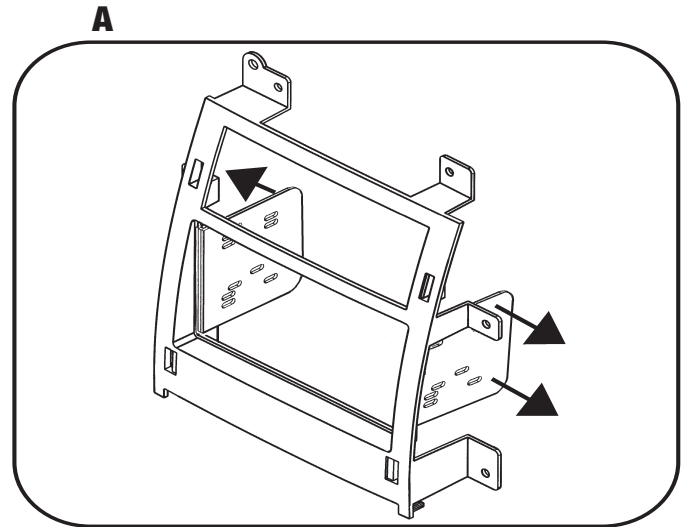

- 2 Slide the pocket into the top of the opening aligning the holes in the radio housing brackets with the bosses on the pocket and secure using the provided (4) #8 3/8" screws. (Figure B)

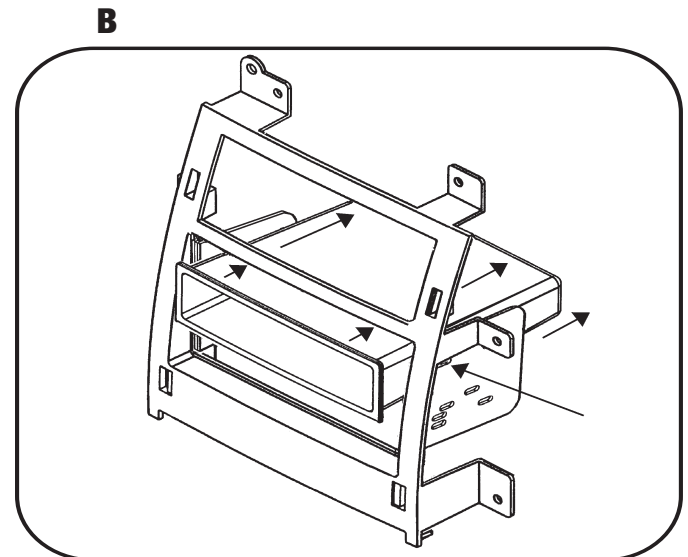

- 3 Slide the ISO radio into the opening below the pocket and secure the unit to the kit using the screws supplied with the radio. (Figure C)

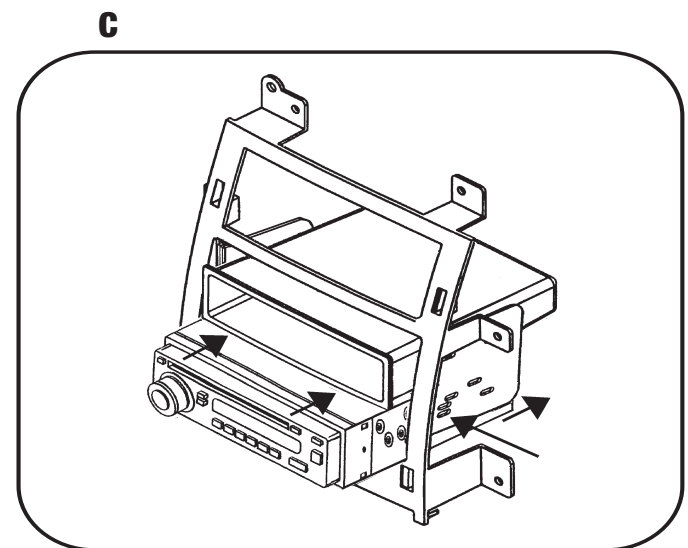

- 4 Snap the radio housing trim plate onto the front of the radio housing. (Figure D)

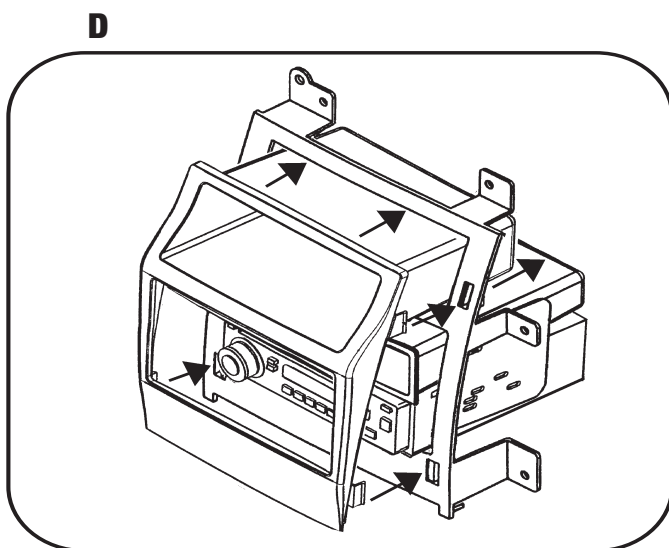

Continue to final assembly.

DOUBLE DIN RADIO PROVISION

**Note: Refer also to the instructions included with the aftermarket radio.*

- 1** Attach the radio housing brackets to the inside edge of the radio housing. (Figure A)
- 2** Slide the Double DIN radio into the radio housing bracket assembly and secure the unit using the screws supplied with the radio. (Figure B)
- 3** Snap the radio housing trim plate onto the front of the radio housing. (Figure C)

Continue to final assembly.

A

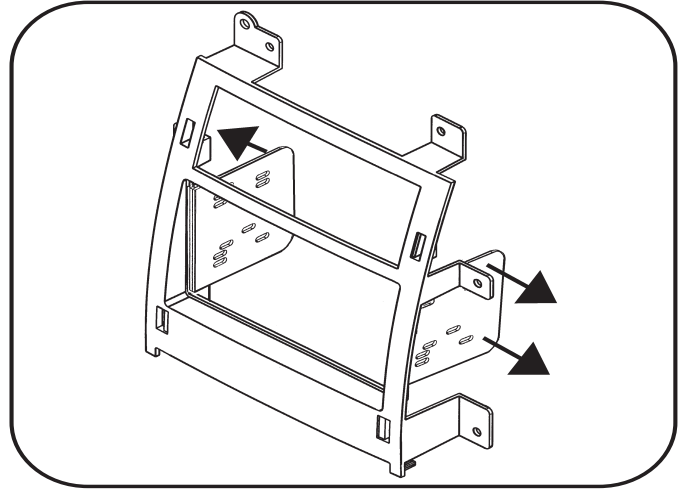

B

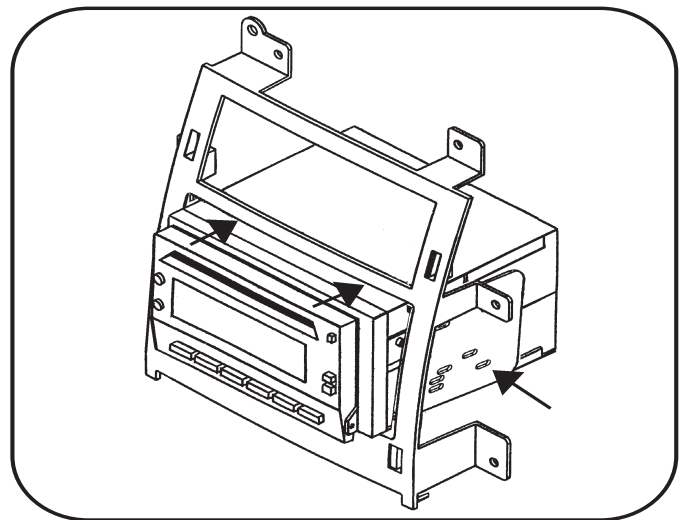

C

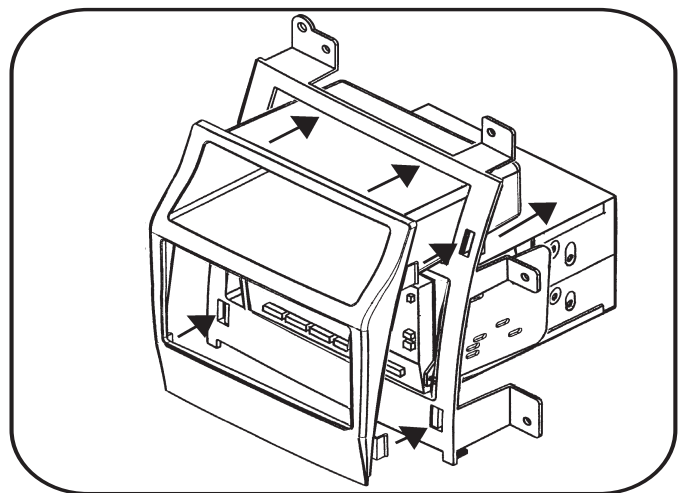

STACKED ISO UNITS PROVISION

**Note: Refer also to the instructions included with the aftermarket radio.*

- 1** Attach the radio housing brackets to the inside edge of the radio housing. (Figure A)
- 2** Slide the stacked ISO units into the radio housing bracket assembly and secure the unit using the screws supplied with the units. (Figure B)
- 3** Snap the radio housing trim plate onto the front of the radio housing. (Figure C)

Continue to final assembly.

A

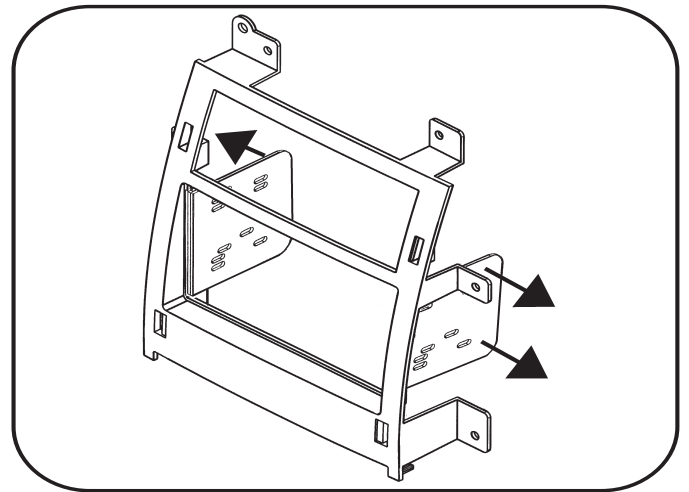

B

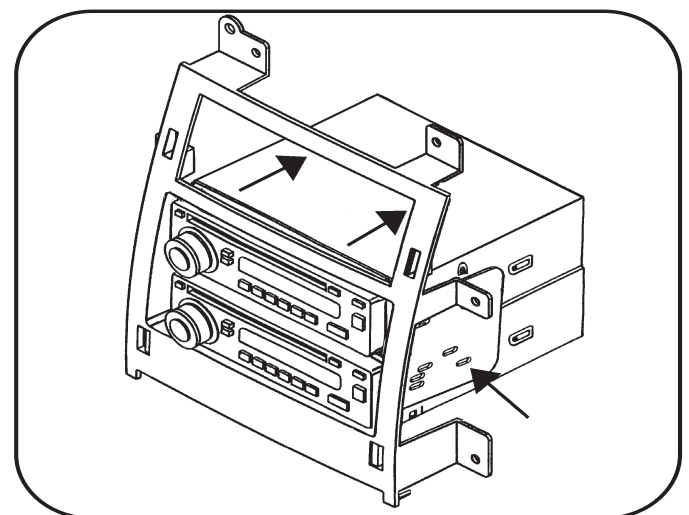

C

