

HI ENERGY

HXS 380 D

2000 watt

SPL

Technical Specifications

Component		Dual Coil Subwoofer
Size	mm	380 (15")
Power Handling (Watt)	peak	2000
	continuous program	1000
Impedance	Ohm	2 + 2
Frequency response	Hz	18-200
Sensitivity	dB/SPL	101
Outer diameter	mm	395
Mounting hole diameter	mm	353
Magnet size	mm	170
Total depth	mm	195
Mounting depth	mm	173
Total driver displacement	lit	3
Weight of one component	kg	9,38
Voice coil diameter	mm	65
Magnet	Double magnet, High density ferrite	
Cone	Water-repellent, non-pressed paper cone	
Xmech*	mm	20

Electro-Acoustic Parameters

D	mm	310
Xmax	mm	10
Re	ohm	3,1
Fs	Hz	26
Le	mH@1kHz	4,30
Le	mH@10kHz	2,00
Vas	lit	97,00
Mms	gr	290,0
Cms	mm/N	0,12
BL	T-m	20,80
Qts		0,32
Qes		0,35
Qms		4,00
Spl (1m/2,83V)	dB	101

Values are given with coils in series connection

* **Xmech** maximum mechanic excursion: it indicates the motion range in the speaker linear functioning area, in both ways.



- Extreme performance, extreme power handling and extreme cosmetics. HXS subwoofers deliver deep, loud aggressive bass.
- High thermal dissipation and magnetic permeability plates.
- Double magnet motor.
- Superior "T" pole.
- SVC® Square Voice Coil special winding on Kapton® former for maximum compactness, lightness and thermal dissipation.
- Aeronautic derivation blues for voice coil, spider and cone.
- Xponential Vented Hole® and lowered bottom plate for long mechanical excursions.
- Water-repellent, non-pressed paper and carbon fibre injections cone.
- Venting Holes, improving dynamics and mobile voice coil cooling.
- Rubber surround for mobile voice coil long, linear excursion.
- CONEX® spider.
- Butylic Damping Cover, it dampens basket vibrations.
- Butyl rubber protective ring for vibrations dampening.
- Aluminium alloy, anti-resonant basket, with anti-scratch paint.
- High current, gold-plated binding posts.

Impedance

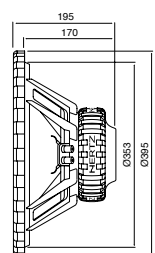
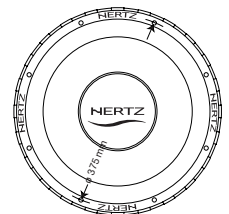
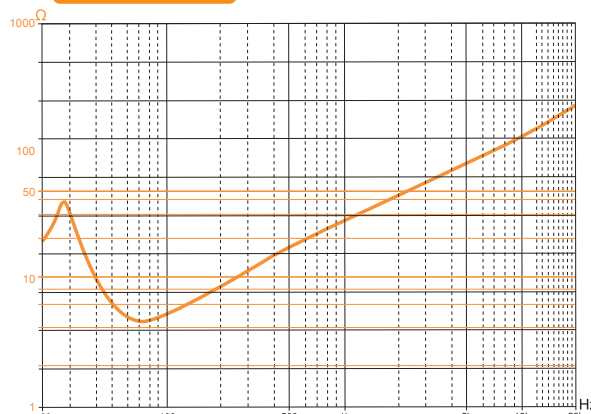

design HXS 380 D

The speaker overall volume must be taken into account when designing a box: if the driver is mounted with its magnet facing the box inner part, add the volume indicated in the Technical Specifications (Total driver displacement) to total volume calculation.

The volumes of Reflex, Asymmetric Bandpass and Double Reflex projects include tubes and ports overall dimensions.

Sealed Box

Sealed Box 1: It optimises overall dimensions as much as possible, for those who have space problems.

Sealed Box 2: It is the best compromise between size and performances; it insures powerful bass and good dynamics.

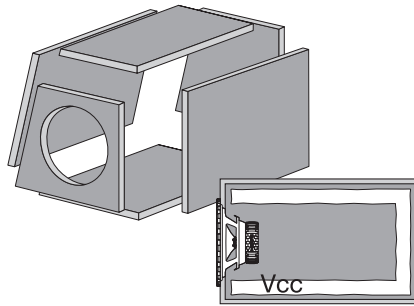

Sealed Box 1

Vcc = 18 Lit
Fc = 65 Hz
F-3 = 56 Hz

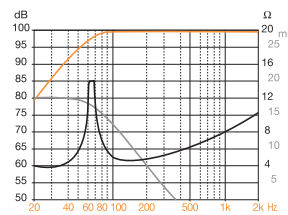

Sealed Box 2

Vcc = 28 Lit
Fc = 57 Hz
F-3 = 56 Hz

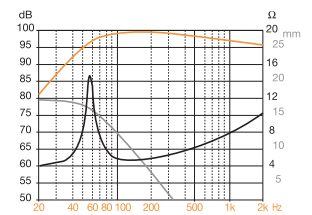

Reflex Box

Bass Reflex 1: Its size is similar to Sealed Box 2 but it offers higher power handling and fast, wide sound.

Bass Reflex 2: The best compromise between size and performances; its bass is more bursting and dynamic than the one you get with the configurations mentioned above.

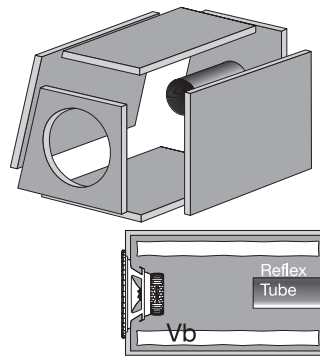

Reflex Box 1

Vb = 30 Lit
Fb = 35 Hz
Reflex Tube
 \varnothing = 85 mm
 L = 230 mm

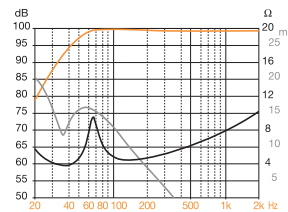

Reflex Box 2

Vb = 43 Lit
Fb = 32 Hz
Reflex Tube
 \varnothing = 85 mm
 L = 230 mm

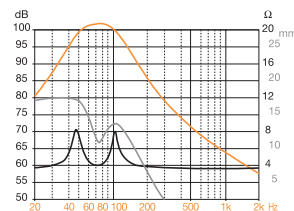
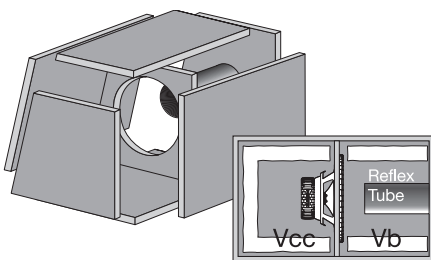
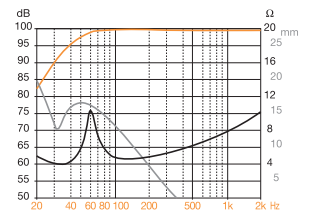

Asymmetric Bandpass

Vcc = 19 Lit
Vb = 24,5 Lit
Fb = 70 Hz
Reflex Tube
 \varnothing = 100 mm x 2
 L = 200 mm

Asymmetric Bandpass

It combines the qualities of the two previous projects with high power handling and fast, clear bass. Suitable to any kinds of music.

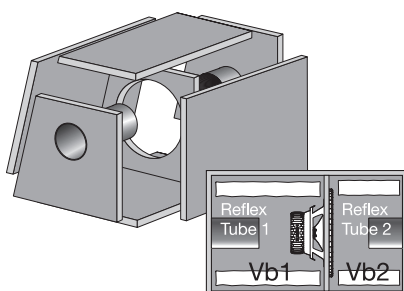

Double Reflex

Vb1 = 25 Lit
Fb1 = 81 Hz
Reflex Tube1
 \varnothing = 85 mm x 2
 L = 90 mm
Vb2 = 29 Lit
Fb2 = 40 Hz
Reflex Tube 2
 \varnothing = 100 mm
 L = 300 mm

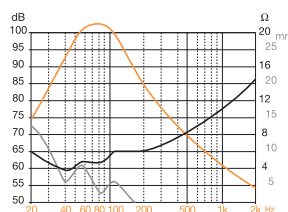

Double Reflex

It is more difficult to build and bigger. It is the best solution to get very high SPL values and bursting, fast sound. Perfect for techno and disco music.