

SUB WOOFER

DiEci

DS 300 300 Watt

Technical Specifications

Component:	Subwoofer	
Size	mm	300 (12")
Power Handling (Watt)	peak	300
	continuous program	150
Impedance	Ohm	4
Frequency response	Hz	28 - 300
Sensitivity	dB/SPL	92
Outer diameter	mm	305
Mounting hole diameter	mm	275
Magnet size	mm	125
Total depth	mm	139
Mounting depth	mm	129
Total driver displacement	lit	1.8
Weight of one component	Kg	2,655
Voice coil diameter	mm	38
Magnet	High density flux ferrite	
Cone	Water repellent, pressed paper	
Xmech*	mm	10

Xmech* maximum mechanic excursion: it indicates the motion range in the speaker linear functioning area, in both ways.

Electro-Acoustic Parameters

D	mm	255
Xmax	mm	4
Re	Ohm	3,5
Fs	Hz	28
Le	mH@1kHz	2,04
Le	mH@10kHz	0,83
Vas	lit	176
Mms	gr	66
Cms	mm/N	0,48
BL	T-m	9,10
Qts		0,46
Qes		0,49
Qms		6,40
Spl (1m/2,83V)	dB	92



- 1 Very high efficiency, superior power handling.
- 2 Pure copper voice coil, wound on aluminium former, for very good thermal and mechanical capacity.
- 3 Vented hole, for more linear excursion and better thermal dissipation.
- 4 Designed to be used in small sealed or reflex box.
- 5 Rubber magnet cover ensures protection and vibrations damping.
- 6 Protective grille included for a thrilling look and speaker protection.

*Grille included

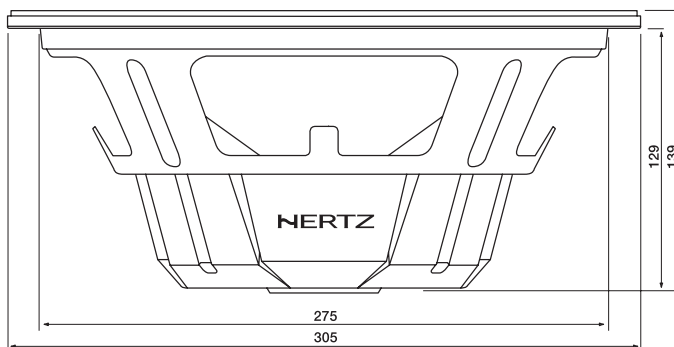

dieci

The Dieci Line represents a new performance landmark in its category. Hertz aimed at obtaining high efficiency, maximum tonal quality and high grade tonal accuracy.

The speaker cones and voice coil formers are made of a special natural paper mixture. Foam surrounds and cotton spiders ensure mechanical reliability and optimal control even under high excursion conditions. The large motor allows tight control of the loudspeaker moving assembly for tight, dynamic output.

The Dieci line is the perfect speaker choice for factory OEM upgrades, direct head power or with high quality amplifiers.

Start the right way: with the first step into the Hertz world.

Thanks to the inverted phase plug and to the very light Mylar membrane, the **DT 16 TWEETER** manages to have the same technical and acoustical benefits of a conventional dome membrane component.

Compact **SIZE**



DIECI WOOFER cone is totally new: the pressed paper V-cone ensures maximum linearity and wide sound dispersion.

DIECI WOOFERS were designed for easy installations in OEM factory speaker locations and are optimized for unique acoustics found in the automotive environment.



The low-loss crossovers, provided with the coaxial and component systems, do not alter the original musical signal, always providing clear, powerful, undistorted sound.

DIECI COAX are provided with Neodimium magnet tweeter featuring built-in crossover for bursting dynamics and DIN size gasket for an easy installation in whatever factory locations.



DIECI SUBWOOFERS provide very high efficiency, as well as superior power handling. The pure copper voice coils are wound on aluminium formers, providing good thermal and mechanical capacity. The vented hole on the bottom plate allows better thermal dissipation and linear excursion.



The **DBX 250** enclosure is made of multi-layer laminated Plywood. The Xponential Flanged Duct ensures maximum linearity of the airflow, providing tight, dynamic bass. The angled rear wall allows easy installation and ensures diffusion of the rear wave for resonance-free performance.

